

Browning[®]

**OtN Helical Bevel
Right Angle
Gearmotors and
Speed Reducers**



the power of
EPT

EMERSON
Industrial Automation

EMERSON. CONSIDER IT SOLVED.

Complete Gearing Solutions...

Standard Solutions

Emerson Power Transmission
Has the Industry's Broadest
Line of Standard Gearmotors
and Speed Reducers



Morse
COBRA™
Worm Gear Reducer



Browning
CbN Inline
Concentric Gearmotor



Browning
MbN Helical
Shaft Mount
Gearmotor



Browning
Motorized Conveyor Pulley



Morse
Raider®
Worm Gear Reducer



Browning
Power-Match Plus
Helical Parallel Shaft
Gear Reducer



Morse
PowerRgear®
Worm Gear
Reducer



Browning
TORQ TAPER® Plus
Shaft Mount
Speed Reducer

OTN Series

Browning[®]

OtN Helical Bevel Right Angle Gearmotors and Speed Reducers

OtN
Series

Gearmotor

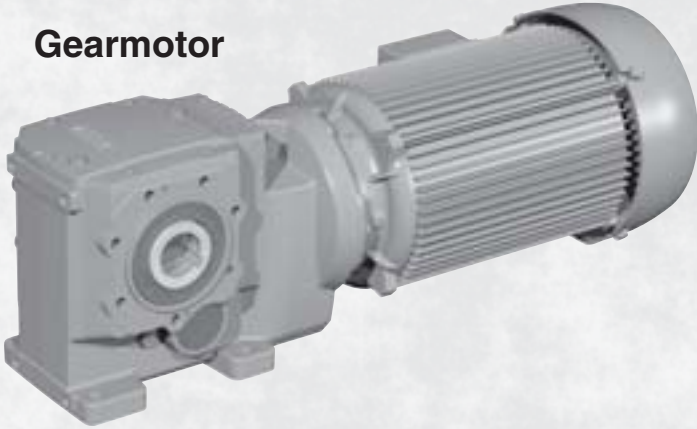

C-Face

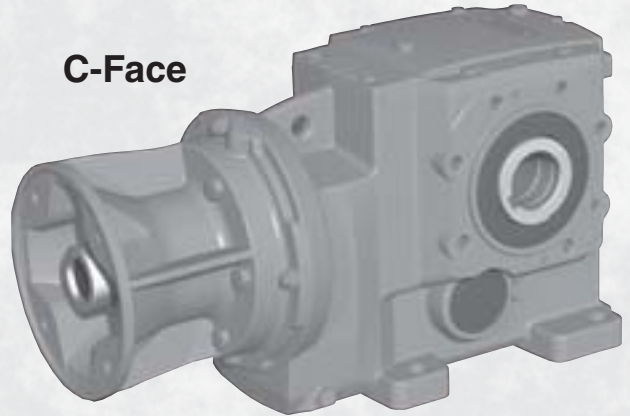

Input Shaft

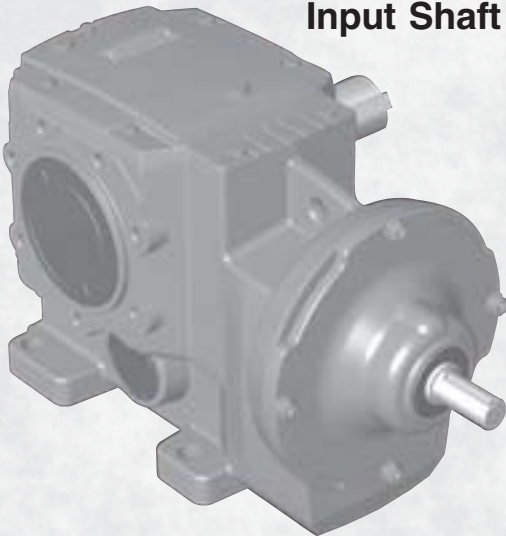

Top Mount

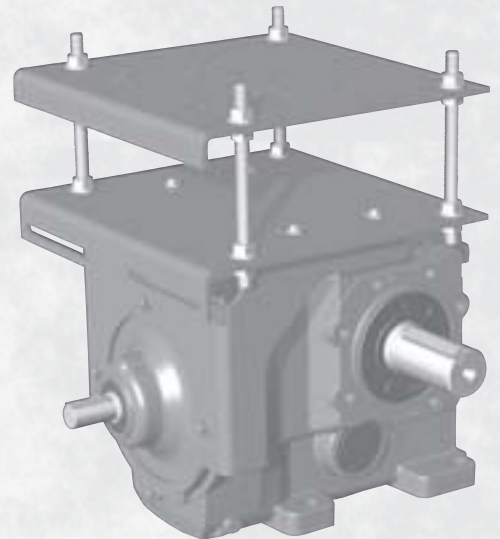

Scoop Mount

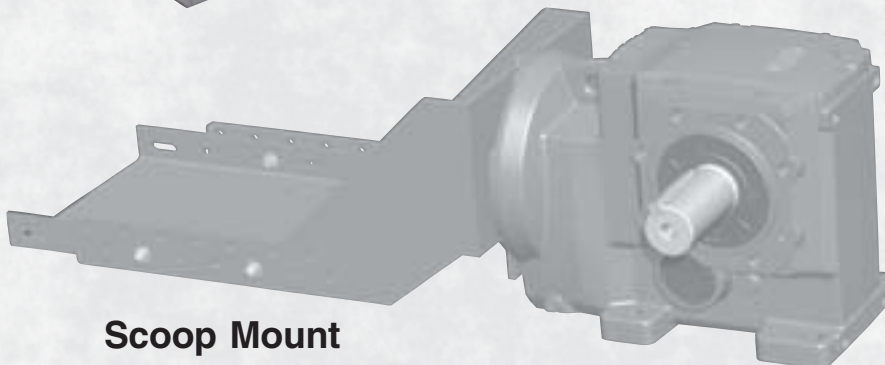

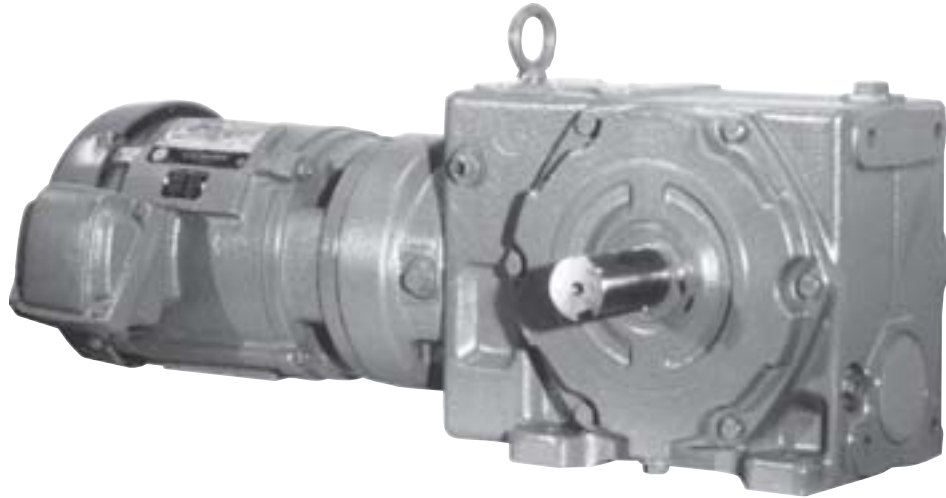

Gearmotor Section..... Page B-5 - B-101

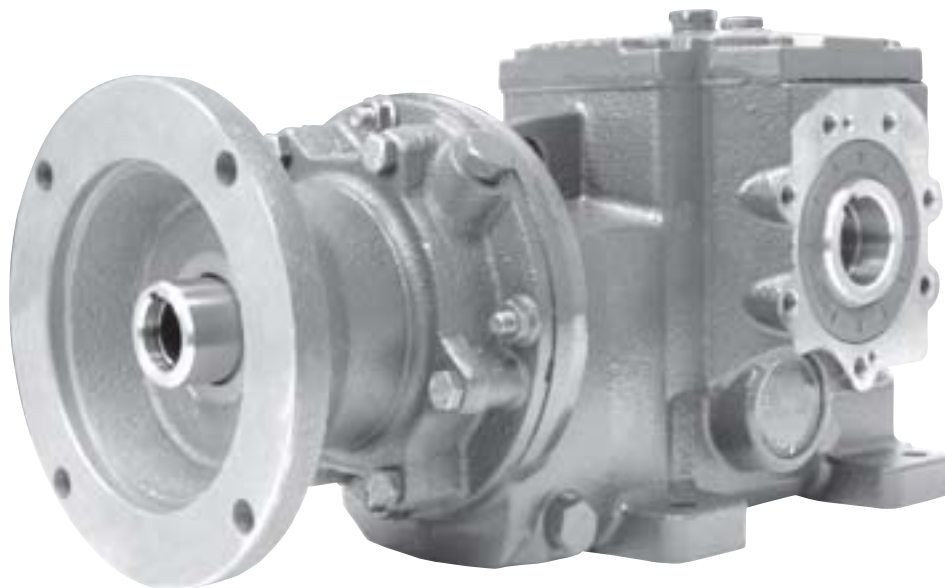

Reducer Section..... Page B-102 - B-187

Mounting Versatility and Size Range

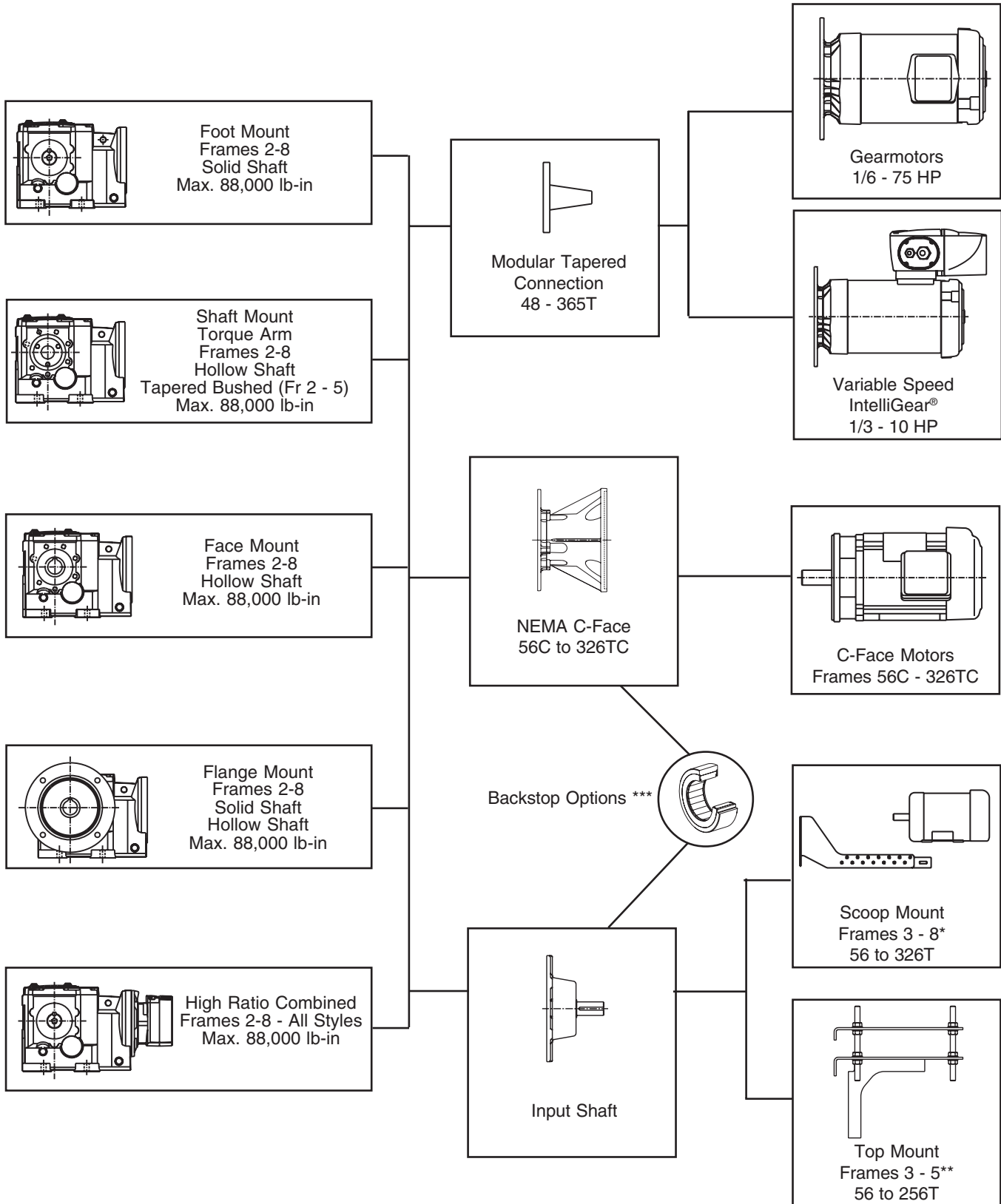

* Not available for frames 2 - 5, 5-stage or frames 4 - 6, 6-stage.

** Only available for frames 3 - 5, 3-stage.

*** Not available for frames 3245 and 3365A. Available input shaft or scoop mount only for frames 6 - 8.

Type OtN Helical Bevel Series 2000/3000 Gearmotor Features...

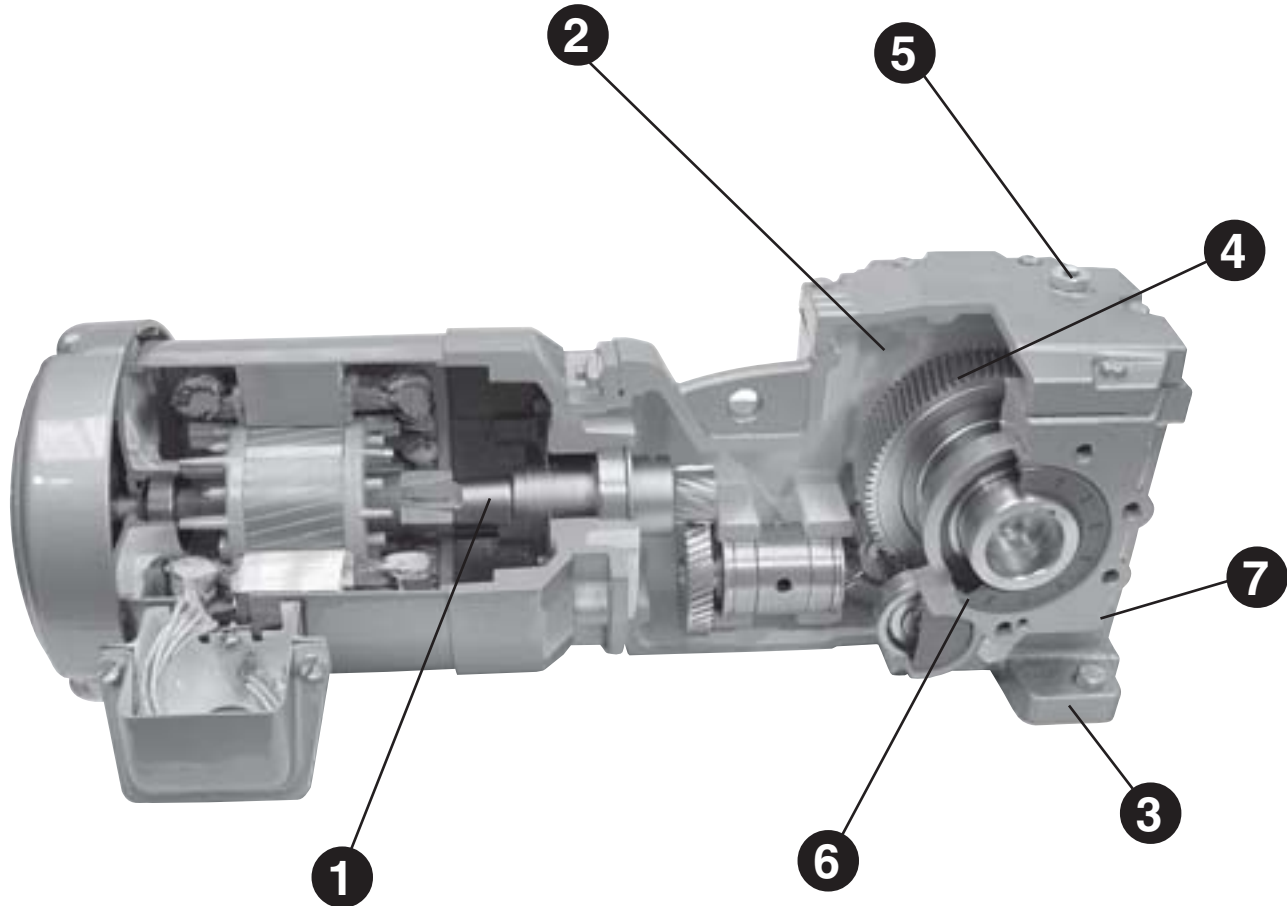

Design Features

- 1. Innovative Self-Locking, Self-Aligning Taper Shaft Motor Connection**
 - Easy on-site motor replacement.
 - Change motor without draining oil, breaking the gearcase seal, or changing primary pinion.
 - Eliminates fretting, ensures precision alignment and solid connection for indexing.
- 2. Gearbox Supplied Factory Filled with Synthetic Oil**
 - Wide temperature range and longer life.
- 3. Corrosion and Shock Resistant Cast Iron Housing**
 - One piece, reinforced and ribbed for extra strength.
- 4. Gears and Shafts of Nickel Chromium Molybdenum Steel**
 - Helical gearing is case hardened and then skived, superfinished or ground.
 - All gears heat shrunk on shafts or mounted on self-locking tapered shafts and keyed for high shock load capability.
- 5. Normally Closed Breather with Multiple Locations (Optional OtN2000)**
- 6. Double Lip Seals on Heat Treated, Plunge Ground Shafts**
- 7. Magnetic Drain Plug Standard**

Table of Contents

Section	Page
General Information	B-7
Mounting Versatility and Size Range	B-8
Motor Options	B-9
Gearmotor Selection (constant speed)	B-10 - B-11
Gearmotor Selection (IntelliGear)	B-12 - B-13
Catalog Nomenclature	B-14 - B-15
Gearmotor Mounting Positions	B-16
Gearmotor Output Brackets and Shafts	B-17
Electrical Connection Options	B-18
Modifications, Options and Accessories	B-19 - B-21
Torque Reaction Arms	B-22 - B-23
Tapered Bushing Selections	B-24
AGMA Application Classifications	B-25 - B-27
Gearmotor Selection Tables	B-28 - B-62
Dimension Prints with Standard TEFC Motors	
Output Shafted Foot Mount	B-64 - B-69
Output Shafted Flange Mount	B-70 - B-75
Finished Bore Hollow Shaft	B-76 - B-81
Finished Bore Hollow Shaft Face Mount	B-82 - B-87
Finished Bore Hollow Shaft Flange Mount	B-88 - B-93
Taper Bushed Shaft Mount	B-94 - B-97
Alternate Motor End Dimension	B-98 - B-99
Type "T" & "S" Motor Brake Dimensional Supplement	B-100
Gearmotor Weights	B-101
Lubrication	B-187
Gearmotor - Typical Motor Performance Data	E-1 - E-4
IntelliGear Technical Specifications	E-5 - E-9
NEMA Standard Dimensions	E-10
General Information	E-11
Standard Terms and Conditions of Sale	E-12

General

OtN helical-bevel right angle gearmotors and speed reducers incorporate the latest in design and manufacturing technologies to deliver an energy efficient, reliable, helical-bevel gear train. This gearing can be combined with either a constant or variable speed motor if a gearmotor is desired. The latest generation of OtN gearing is 98% efficient per gear stage, with three, five or six stages available for ratios of 10:1 to 10,000:1. OtN is available in a wide variety of mounting arrangements that include foot mount, face mount, flange mount or shaft mount with a torque arm. The output can be left, right, or dual solid shaft or shaft mounted with hollow quill or new tapered bushed.

Housing

The unique housing design allows the OtN3000 to directly interchange with many popular competitive products, while offering a version that also replaces the OtN2000 sizes that it replaces. This allows for simple aftermarket replacement of both OtN2000 and many of the more common helical-bevel products from other manufacturers. All housings are cast from high-strength cast iron. Additionally, the new, quill style c-face of OtN3000 is often shorter than competitive designs, while allowing room for a fully rated backstop.

Performance

OtN designs deliver ratings that are amongst the highest in the industry for similar frame sizes. For replacements, this means that dimensional replacements generally meet or exceed the original unit ratings for long life. In new applications, this can mean cost savings through downsizing versus the competition. Each OtN unit is also supplied factory-filled with high quality synthetic lubricant, an extra cost option for competitive units. This offers operation over a wide temperature range with minimal maintenance required.

Flexibility

The new OtN3000 offers a shaft-mounted version that incorporates the tapered bushing system from the Browning® Torque Taper Plus® shaft mount reducer. This extends each frame size to be usable on a variety of shaft sizes. It also provides a proven bushing system with a centering ring that reduces wobbling on the shaft for reduced wear and tear. All sizes are also available with a hollow quill sized to match popular competitive units. The bushed version of OtN3000 includes a bushing to match the OtN2000 equivalent frame size for replacements. The shaft-mounted units all include feet on the housing base and they can be tied down to the machine frame using a face mount, flange mount, or torque arm. There are two flanges available in each OtN3000 frame size, one of which is competitively interchangeable. Also, for applications requiring the gearmotors to be powered by an inverter (VFD), all three phase motor designs now incorporate an upgraded wire and varnish treatment called Allguard. Housings can be mounted in a variety of positions as well, with only a change in the breather and drain plug positions and a change in oil volume.

Gearmotors

The industry's most diverse array of different motor constructions and voltages in three and single phase are stocked to meet most industry and user specifications. This now includes IntelliGear variable speed TEFC gearmotors that incorporate a rugged, compact, pre-programmed AC variable frequency drive onboard for simple 6:1, 10:1, or 15:1 constant torque speed ranges. Emerson Power Transmission exclusive offerings are the inverter duty gearmotors that are fully compliant with NEMA MG1 Part 31 and the explosion proof gearmotors.

Reliability

Gear housing sizes 2-5 are fitted with normally closed breathers to exclude contaminants, while preserving low internal operating pressure. All oil seals operate on plunge ground shaft surfaces to deliver extended life. Enhanced insulating materials and other standard features of our premium Varidyne inverter duty motors allow Emerson Power Transmission to extend an industry leading 3-year motor warranty, even when using these motors with PWM inverter power up to 575 VAC.

Mounting Versatility and Size Range

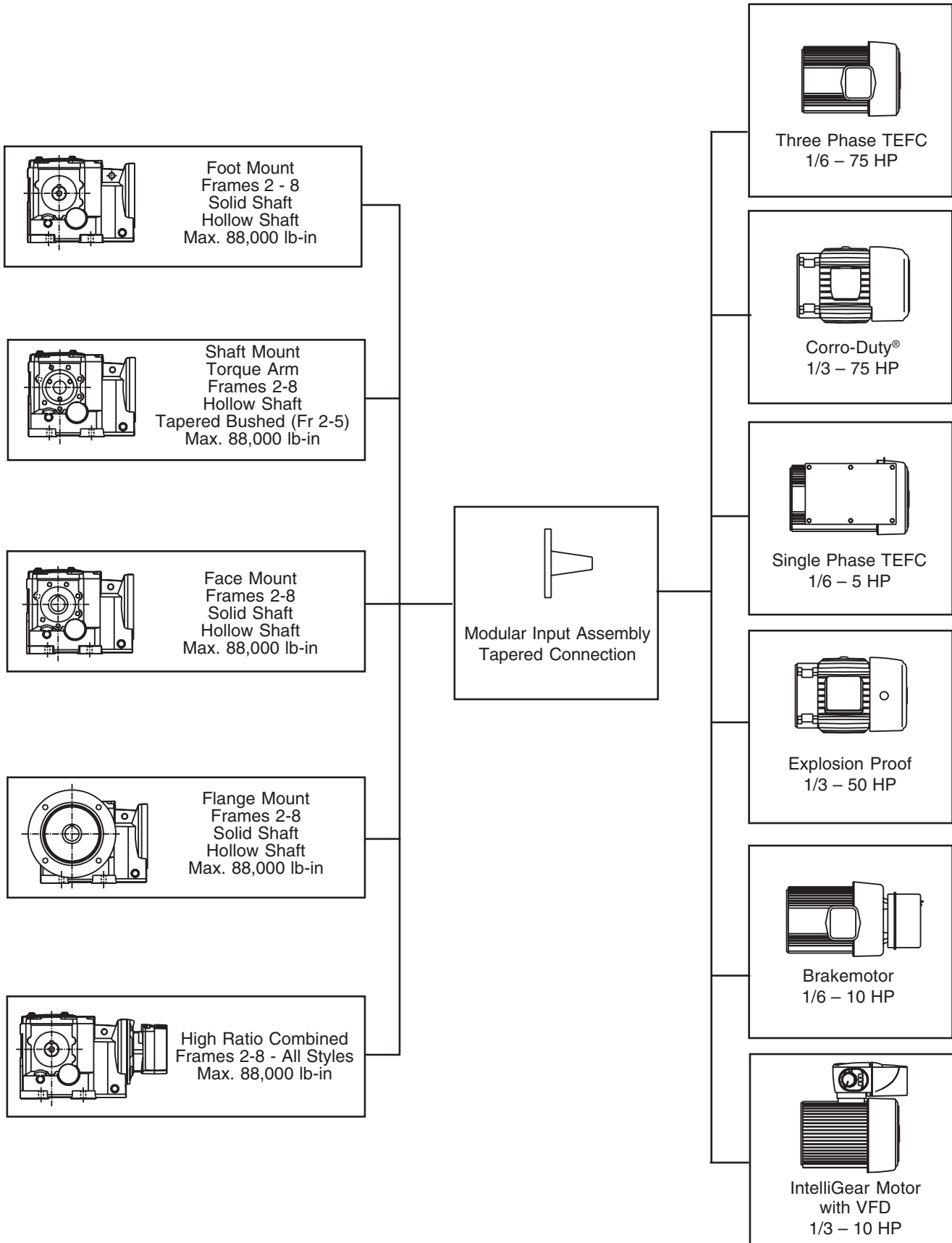



TEFC – Three Phase

- Suitable for general purpose industrial applications
- Energy efficient design standard
- 1.25 service factor through 30 HP; 1.15 service factor above 30 HP
- Suitable for 50 Hz, 190/380 VAC through 30 HP
- Premium class F Allguard insulation standard
- 40°C ambient, NEMA B design, continuous duty
- Premium efficiency available
- Inverter duty option per NEMA MG1 part 31 stocked



Corro-Duty

- Designed for wet, corrosive applications and industries including waste treatment, mining and lumber.
- All cast iron construction (56 and 140 frames are rolled steel)
- Premium efficiency standard 3 HP and above
- 1.15 service factor, class F Allguard insulation
- Condensation drains in motor and conduit box
- 40°C ambient, NEMA design B, continuous duty
- Inverter duty version per NEMA MG1 Part 31 stocked to 20 HP

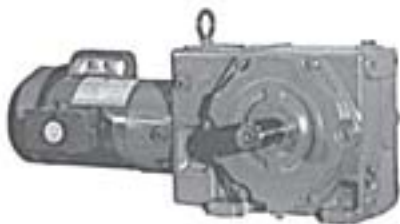

TEFC – Single Phase

- For agricultural, light material handling, textile, and light pumping applications
- 1.25 service factor
(1.15 service factor, 1 HP, 48 frame)
(1.0 service factor, 2 HP and 1.15 service factor, 3 - 5 HP)
- Capacitor start
(capacitor run above 1/2 HP, 48 frame)
(capacitor run above 1/2 HP, 56 – 180T frames)
- Class B insulation, continuous duty, reversible



Explosionproof

- Ideal for the petro-chemical, grain, mining, and chemical industries
- Class I, group D, class II, groups F and G
- All cast iron construction (plastic fan cover)
- 1.0 service factor, class B insulation
- 40°C ambient, NEMA B design, continuous duty
- UL approved Inverter duty per NEMA MG1 part 31 stocked



IntelliGear

- Variable speed gearmotor with NEMA 4/12 enclosure
- "Onboard" pushbutton and remote speed changing options
- Pre-programmed 6:1 constant torque speed range
- Versions for 3/460V input power supplies from 1/3 to 10 HP
- 1/230V and 3/230V to 5 HP
- 1/115 V through 3/4 HP
- UL, CUL and CE
- Optional 10:1 and 15:1 speed ranges

Selection Information

- Input HP
 - Based on application data
- Speed / ratio
 - Obtain either desired output speed (RPM) or gearbox ratio based on application.
- Mechanical service factors - gears
 - There are three standard classifications for gearmotor applications:

Class I - uniform loading, 3-10 hours per day, service factor 1.0 (minimum).

Class II - uniform loading over 10 hours per day or moderate shock loading up to 10 hours per day; service factor 1.4 (minimum).

Class III - moderate shock loading over 10 hours per day or heavy shock loading up to 10 hours per day; service factor 2.0 (minimum).

- The tables on pages B-25 through B-27 are based on past operating experience within the industries listed and information gathered by AGMA. If the user has data reflecting greater severity than normal industry usage, then the AGMA class should be increased.
- Choose the AGMA class for your given application based on this criteria. If your application cannot be found, use the following table to determine the service factor.

Duty Cycle	Hours Operation	Uniform Load U	Moderate Shock Load M	Heavy Shock Load V
Continuous	0 - 3	0.80	1.00	1.50
	3 - 10	1.00	1.25	1.75
	10 - 24	1.25	1.50	2.00
Frequent Starts/Stops*	0 - 3	1.00	1.25	1.75
	3 - 10	1.25	1.50	2.00
	10 - 24	1.50	1.75	2.25

*Greater than 10 per hour

Size Selection

Step 1 - Locate gearmotor selection tables (pages B-28 - B-62) based on motor HP.

Step 2 - Choose the appropriate nominal speed or ratio required.

Step 3 - Select the correct gearmotor based on AGMA class or service factor determined from selection information.

Step 4 - Verify overhung load ratings where required (see below).

Overhung Load

When a sprocket, sheave, pulley, or pinion is mounted on the take-off shaft of a gearmotor, it is necessary to calculate the overhung load. This calculated load must be compared with the gearbox capacity listed to make sure the gearbox will not be overloaded. To calculate the overhung load you need to know the torque or horsepower at the take-off shaft and the location along the shaft at which the load is applied.

A. If torque is known:

$$OHL = \frac{T \times K \times LLF}{r}$$

B. If horsepower is known:

$$OHL = \frac{63025 \times HP \times K \times LLF}{RPM \times r}$$

Where:

- OHL = Overhung load (pounds)
- T = Torque (in. lbs.)
- r = Radius of driving member (in.)
- HP = Horsepower
- K = Drive type factor
- LLF = Load location factor

Driving Member	Value of K
Chain Drive	1.00
Pinion	1.25
V-Belt	1.50
Timing Belts	1.25

Load Location	Value of LLF
End of shaft extension	1.20
Center of shaft extension	1.00
Shaft extension shoulder	0.80

Selection Example

A right angle, foot mounted gearmotor is required to operate a uniformly loaded belt conveyor at 30 RPM, 24 hours per day. An 11" diameter sprocket is mounted at the end of the shaft and drives the conveyor with a chain drive. The customer has specified a standard 230/460 VAC, 3-phase, TEFC gearmotor rated 5 HP. Shaft extension is to be on the right, viewing the motor fan cover. The unit will be in the normal floor mounted position with the motor horizontal and the mounting feet on the bottom.

Refer to AGMA service classification table on page B-25.

Application	Load	Class	
Conveyors – Uniformly Loaded or Fed: Apron, Assembly, Belt, Bucket, Chain, Flight, Oven, Screw	U	Up to 10 Hrs/Day	Over 10 Hrs/Day
		I	II

Since this application operates 24 hours per day, a Class II service factor is required.

Step 1... Locate a gearmotor for 5 HP on page B-48.

Step 2... Find a nominal speed closest to the 30 RPM output required.

Step 3... Select the row in the table for Class II service factor.

Output rpm	AGMA Class	Service Factor	Output Torque in-lb	OHL lb	Nominal Ratio	Frame Size Gear	Motor	Std. Motor Types
31	I,II	1.4	9661	2875	56	3473	184T	T,C,S,X,IG
28	I	1.3	10491	2875	63	3473	184T	T,C,S,X,IG

30 rpm falls between these two lines in the selection table, but the 28 rpm line doesn't meet the Class II service factor requirement. Size 3473 gear frame with 56:1 nominal ratio and 31 rpm output is the best selection.

Step 4... Verify that the Overhung Load Rating is sufficient for the applied load.

$$r = \frac{\text{Sprocket Diameter}}{2} = \frac{11}{2} = 5.5"$$

$$K = 1.0 \text{ (chain drive)}$$

$$LLF = 1.2 \text{ (sprocket on end of shaft)}$$

$$HP = 5$$

$$OHL = \frac{63025 \times HP \times K \times LLF}{rpm \times r} = \frac{63025 \times 5 \times 1.0 \times 1.2}{31 \times 5.5} = 2217.9 \text{ lbs.}$$

Since the gearmotor output OHL rating is 2875 lbs (see selection table) and this is greater than the applied OHL of 2217.9 lbs, the selection is fine. If the OHL rating was too low, the sprocket diameter or gear frame could be increased.

Complete the Process by Building a Complete Part Number

Catalog designation (see "Catalog Nomenclature" page B-14):

OtN • 3473 • S2 • B33G • 56 • MT • 184T • 5

The codes indicate the following: Frame 3473 OtN Gearmotor, S2 = the standard output shaft and mounting dimensions, B = Floor Mount, 33 = No Faces or Flanges, G = Single Shaft on Right Facing Motor Fan, 56:1 Ratio, MT = Standard TEFC Motor, 184T Motor Frame, 5 HP. (Page B-16 shows mounting positions, page B-17 explains output shaft and face or flange positions, and page B-15 shows motor types.)

Gearmotor Selection

Selection Information

- Determine installation environment
 - Control enclosure is NEMA 4/12
- Input HP
 - For constant torque loads this is at maximum speed of range. Therefore, the gear ratio should be selected to closely match the required maximum speed.
- Speed range
 - Confirm maximum and minimum of needed range.
- Determine control power supply
 - Phase and voltage

Power Supply	Input HP's
1 ph / 115 v	.33 to .75
1 ph / 230 v	.33 to 2
3 ph / 230 v	.33 to 5
3 ph / 460 v	.33 to 10
3 ph / special	R. O.

- Mechanical service factoring of gear
 - Refer to page B-10 for this procedure.

Note: IntelliGear application for 1 phase power supply is limited to 10 starts per hour where the unit is started via AC power mains contactor.
- Determine speed adjustment option
 - Select from:
 - PD = Digital keypad with forward/reverse/stop/speed up/speed down/speed display on IntelliGear enclosure
 - P1 = Run/stop/speed pot. mounted on IntelliGear enclosure
 - P2 = Forward/reverse/stop/pot. mounted on IntelliGear enclosure
 - P3 = Speed pot. (only) mounted on IntelliGear enclosure (start/stop by others)
 - P4 = Speed pot. (only) mounted inside IntelliGear enclosure (start/stop by others)
 - R = Remote signal following (0-10VDC or 4-20mA supplied by others)
 - RP = Remote from fieldbus - Profibus DP
 - RI = Remote from fieldbus - Interbus S
 - RD = Remote from fieldbus - Devicenet

Size Selection

Step 1 - Determine the maximum motor RPM from the following table based on the whether the application requires a speed range of 6:1, 10:1 or 15:1.

$$\text{Speed Range} = \frac{\text{Maximum Output Speed Required}}{\text{Minimum Output Speed Required}}$$

HP	IntelliGear Motor Speed Range		
	6:1 Speed Range	10:1 Speed Range	15:1 Speed Range
1/3 - 3/4 HP	1760 - 293 rpm	1760 - 176 rpm	2625 - 175 rpm
1 - 1 1/2 HP	1750 - 291 rpm	1750 - 175 rpm	2620 - 175 rpm
2 HP	1750 - 291 rpm	2585 - 255 rpm	N. A.
3 HP	1750 - 291 rpm	2630 - 263 rpm	N. A.
5 HP	2150 - 358 rpm	2605 - 260 rpm	N. A.
7.5 HP	2150 - 358 rpm	2670 - 267 rpm	N. A.
10 HP	2100 - 350 rpm	2600 - 260 rpm	N. A.

- Determine the gear ratio required. Use the maximum motor rpm from the table above.

$$\text{Gear Ratio} = \frac{\text{Maximum Motor Speed}}{\text{Maximum Output Speed Req'd}}$$
- Locate gearmotor selection tables based on the input HP required at the ratio calculated in Step 2. Select the nominal gear ratio closest to the one calculated.
- Select the correct gearmotor that meets or exceeds the AGMA class or service factor determined in the selection information.
- Verify overhung load rating where applicable per formulas on page B-10.
- Confirm input power supply is compatible with HP of selection and select the speed adjustment option desired for the application.
- Referring to page B-18, determine if an alternative controller location is required for the application. (Note that the default location is "FO" – the 12 o'clock position.)

Selection Example

A right angle, flange mounted gearmotor is required to operate a mixer for a variable density solution. The mixer operates 8 hours per day, and the speed range is 12-56 RPM. The mixer shaft will be directly coupled to the gearmotor output shaft on the right side viewed from the motor end. The customer has specified a 2 HP gearmotor with a standard TEFC motor, and the power supply is 460 VAC, 3-phase. The flange is to be located on the right, viewing the motor fan cover, and the OD required is 250 mm. The unit will be mounted on its side with the motor horizontal and the output shaft vertical. Viewed from the top of the gearcase housing, the motor will be mounted to the right.

Refer to AGMA service classification table on page B-26.

Application	Load	Class	
		Up to 10 Hrs/Day	Over 10 Hrs/Day
Mixers (Also see Agitators):			
Concrete - Continuous	M	II	II
Concrete - Intermittent	M	I	-
Constant Density	U	I	II
Variable Density	M	II	II

Since this mixer is variable density and operates 8 hours per day, a Class II service factor is required.

Step 1... Calculate the speed range required: 56 rpm max./12 rpm min. = 4.7:1, so an IntelliGear with 6:1 range is required. This means the motor top speed will be 1750 rpm for a 2 HP IntelliGear.

Step 2... The ideal gear ratio is 1750 rpm / 56 rpm = 31.25:1.

Step 3... Locate gearmotor for 2 HP on page B-42, and find a nominal ratio close to 31.25:1.

Step 4... Select the row in the table for Class II service factor.

Output rpm	AGMA Class	Service Factor	Output Torque in-lb	OHL lb	Nominal Ratio	Frame Size Gear	Motor	Std. Motor Types
57	I, II, III	3+	2074	2090	31.5	3363	145T	T,C,S,X,IG
57	I, II	1.8	2088	1273	31.5	3243	145T	T,C,S,X,IG
51	I, II, III	3+	2346	2090	35.5	3363	145T	T,C,S,X,IG

Note that 31.25:1 ratio is closest to 31.5:1 nominal ratio. There are two choices at this ratio, and both meet the Class II service factor requirement. This means that the smaller Size 3243 gear frame will be the most economical selection.

Step 5... For a direct coupled application, it is not necessary to consider the Overhung Load Rating.

Step 6... The power supply is 460 VAC/3-phase, and there is an IntelliGear available for this voltage at 2 HP. (See the footnote at the bottom of page B-42.)

Complete the Process by Building a Complete Part Number

Catalog designation (see "Catalog Nomenclature" page B-14):

OtN • 3243 • S2 • T53G • 31.5 • T4 • 145TY • 2

The codes indicate the following: Frame 3243 OtN Gearmotor, S2 = the standard output shaft and mounting dimensions, T = Wall Mount with motor to the right, 53 = Flange on right side, G = Single Output Shaft on the right side, 31.5:1 Nominal Ratio, T4 = 460 VAC/3-Phase IntelliGear, 145TY Motor Frame (See footnote on page B-42), 2 HP. (Page B-16 shows mounting positions, page B-17 explains output shaft and face or flange positions, and page B-15 shows motor types.)

OtN • 34 7 3 • S2 • B 33 G • 22.4 • MT • 145T • 1.5 • M11

See page B-16 - B-17

Browning Right-Angle Helical-Bellev	Series	Reducer Size	Stages	Shaft & Foot Dimensions ¹	Mounting Position	Output Face/Flange Viewed From Input End	Output Shaft Configuration Viewed from Input End	Nominal Gear Ratio	Input Type	Motor Frame	Motor HP	Modifications
Series 3000	32	4	3 = 3 stages	S1 = OtN2000 replacement dimensions	B = Floor mount	3 = Standard round	G = Shaft right	22.4 = 22.4:1	Motor type selected from catalog designation column in standard motor input types table on page B-15	48 - 365T	1.5 = 1.5 HP	Select from modifications listed on pages B19 - B21
	33	6	5 = 5 stages combined	S2 = Industry interchange dimensions	P = Ceiling mount	4 = Face mount	D = Shaft left	Use nominal ratio selected from gearmotor selection tables				
	34	7	6 = 6 stages combined		H = Wall mount, input left	5 = Standard dimension flange mount	X = Dual shaft					
	35	8			T = Wall mount, input right	6 = Alternate dimension flange mount	C = Finished bore					
Series 2000	26	0	3 = 3 stages	S1 = All Series 2000 Units	V = Input vertical up		B = Tapered bushed					
	27	0	5A = 5 stages combined		W = Input vertical down		S = Screw conveyor shaft and adapter					
	26	0	6A = 6 stages combined									

¹ Shaft and critical mounting dimensions match either OtN2000 or SEW® "K" Series units. These dimensions include the mounting base, output flanges, output shaft diameter, distance from housing center line to shaft tip, and output quill diameter. B14 mounting faces and overall product envelope (height, width, depth) do NOT match.

SEW is believed to be a trade name of SEW-Eurodrive GMBH & Co. and is NOT owned or controlled by Emerson Power Transmission. Emerson Power Transmission Corporation cannot and does not represent or warrant the accuracy of this information.

OtN2000/3000 Gearmotors									
Motor Frame	48	56	143T 145T 145TY	182T 184T	213T 215T	254T 256T	284T 286T	324T 326T	364T 368T
Gear Frame	Range of Ratios Available								
3243	10:1 - 160:1	10:1 - 160:1	10:1 - 160:1	10:1 - 100:1					
3245/3246		180:1 - 10,000:1	180:1 - 10,000:1						
3363		10:1 - 160:1	10:1 - 160:1	10:1 - 140:1	10:1 - 90:1				
3365/3366	180:1 - 900:1	180:1 - 10,000:1	180:1 - 10,000:1	180:1 - 900:1					
3473		10:1 - 160:1	10:1 - 160:1	10:1 - 160:1	10:1 - 100:1	10:1 - 100:1			
3475/3476	180:1 - 10,000:1	180:1 - 10,000:1	180:1 - 10,000:1	180:1 - 10,000:1					
3583		14:1 - 160:1	14:1 - 160:1	14:1 - 160:1	14:1 - 160:1	10:1 - 125:1	10:1 - 56:1		
3585/3586	180:1 - 10,000:1	180:1 - 10,000:1	180:1 - 10,000:1	180:1 - 10,000:1					
2603				56:1 - 100:1	12.5:1 - 100:1	12.5:1 - 90:1	12.5:1 - 50:1		
2605/2606		125:1 - 10,000:1	125:1 - 10,000:1	125:1 - 10,000:1	125:1 - 2,000:1	125:1 - 2,000:1			
2703				100:1	45:1 - 100:1	22.4:1 - 90:1	12.5:1 - 63:1	12.5:1 - 50:1	12.5:1 - 50:1
2705/2706		140:1 - 10,000:1	140:1 - 10,000:1	140:1 - 10,000:1	140:1 - 500:1	140:1 - 500:1			
2803					80:1 - 100:1	35.5:1 - 100:1	25:1 - 90:1	12.5:1 - 63:1	12.5:1 - 63:1
2805/2806		112:1 - 9,000:1	112:1 - 9,000:1	112:1 - 9,000:1	112:1 - 2,500:1	112:1 - 630:1	112:1 - 280:1		

Flange Dimensions (mm)								
BD	200	250	300	350	400	450	550	
AK	130	180	230	250	300	350	450	
AJ	165	215	265	300	350	400	500	
Gear Frame	Output Flange Part Number Designator							
32	5	6						
33		5	6					
34			5	6				
35				5	6			
26						5		
27						5		
28								5

Standard Motor Input Types

Motor Type	Speed - Design	Catalog Designation	Motor Description (not required)		
			Frame(s)	Voltage	Poles
S (Single phase TEFC)	Single	MR	48 - 145TY	115/230	4
		MR2	184T	230	4
T (Three phase TEFC)	Single standard efficiency	MT	48 - 286T	208-230/460	4
		MB	324T - 365T	230/460	4
		MV	48 - 365T	575	4
		MO	56 - 256T	230/460	6
		MW	56 - 256T	575	6
	Single premium efficiency	MY	143T - 365T	230/460	4
		MZ	143T - 365T	575	4
	Inverter duty	MI	56 - 365T	230/460	4
		MD	56 - 365T	575	4
	Two speed (constant torque)	U2	56 - 365T	230	4/8 - 1 winding
U4		56 - 365T	460	4/8 - 1 winding	
U5		56 - 365T	575	4/8 - 1 winding	
Single	Z1	56 - 365T	Special **	4	
	Z2	56 - 365T	Special **	6	
C Corro-Duty three phase	Single standard efficiency	MC	56 - 145TY	230/460	4
		MG	56 - 145TY	575	4
		MF	56 - 256T	230/460	6
	Single high efficiency	MC	143T - 365T	230/460	4
		MG	143T - 365T	575	4
	Two speed (constant torque)	C2	56 - 365T	230	4/8 - 1 winding
		C4	56 - 365T	460	4/8 - 1 winding
		C5	56 - 365T	575	4/8 - 1 winding
Inverter duty	CI	56 - 365T	230/460	4	
	CD	56 - 365T	575	4	
X Explosionproof	Single	MX	56 - 326T	230/460	4
		ME	56 - 326T	575	4
		Z7	56 - 326T	230/460	6
	Two speed (constant torque)	X2	56 - 326T	230	4/8 - 1 winding
		X4	56 - 326T	460	4/8 - 1 winding
		X5	56 - 326T	575	4/8 - 1 winding
	Inverter duty	X1	56 - 326T	230/460	4
		XD	56 - 326T	575	4
	IG IntelliGear TEFC/NEMA 4/12 (motor/controller)	6:1 Range *** (constant torque) variable speed	TS1	56	1/115 *
TS2			56 - 145TY	1/230 *	4
T2			56 - 184T	3/230 *	4
T4			56 - 215T	3/460 *	4

* Controller input power. Controller output is 3 phase.

** Refer to modifications M5 and M6.

*** 10:1 and 15:1 constant torque speed ranges are also available.

Gearbox Position (defined by a letter)

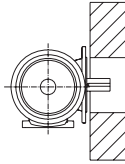
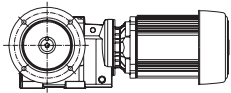
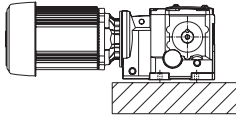

B

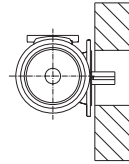
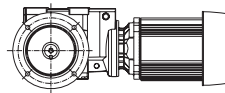
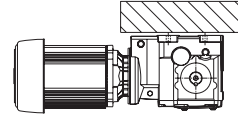

P

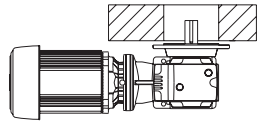
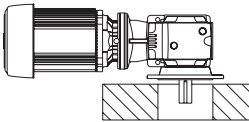
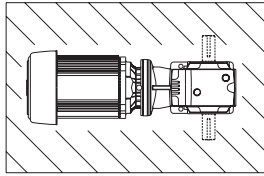

H

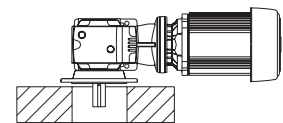
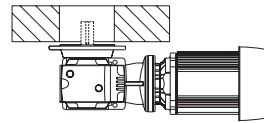
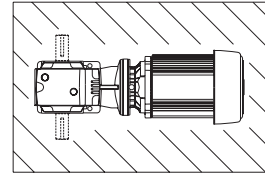

T

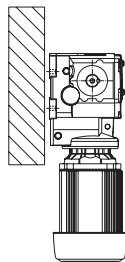
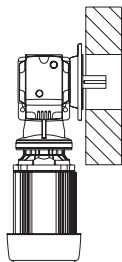

W

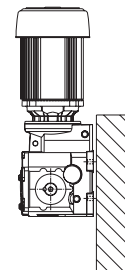
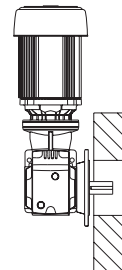

V

Output Bracket Options

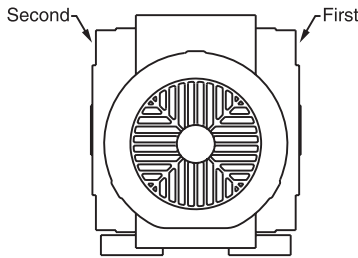

View motor fan end

Define in order shown



Plain = 3



Face = 4



Flanged = 5 or 6

Output Shaft Arrangement

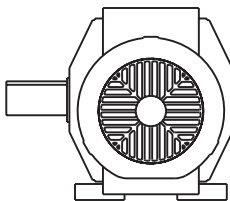

Left = D

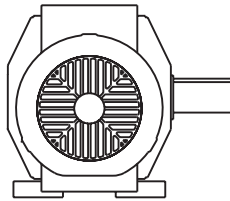

Right = G

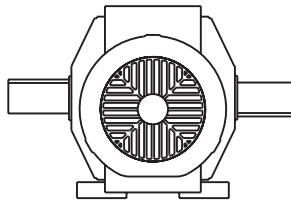

Left / Right = X

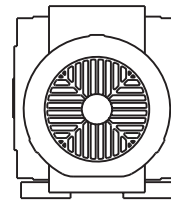

Hollow Bore = C

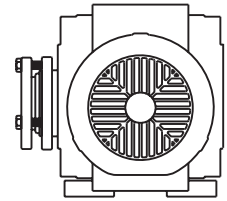

Taper Bushed = B*

* Bushing may be field reversed to opposite side.

Example: Standard floor mount, shaft output on right (facing motor).

B
Floor Mount

3
Right Output Endshield

3
Left Output Endshield

G
Shaft Output on Right

OtN Frame	Foot Mounted			Face Mounted			Flange Mounted						Shaft Mounted		
	Solid Shaft			Hollow Shaft			Solid Shaft			Hollow Shaft			Hollow	Bushed	
	33G	33D	33X	33C*	34C	43C	44C*	53G	35D	55X	53C	35C	55C*	33C*	33B*
32	●	●	●	●	●	●	●	●	●	▲	●	●	●	●	●
33	●	●	●	●	●	●	●	●	●	▲	●	●	●	●	●
34	●	●	●	●	●	●	●	●	●	▲	●	●	●	●	●
35	●	●	●	●	●	●	●	●	●	▲	●	●	●	●	●
26	●	●	●	●	●	●	●	●	●	▲	●	●	●	●	-
27	●	●	●	●	●	●	●	●	●	▲	●	●	●	●	-
28	●	●	●	●	●	●	●	●	●	▲	●	●	●	●	-

If shaded, the alternative flange "6" is also available.

● This is available at normal lead-times.

▲ This item is available at production lead-times.

- Refer to office for design review.

* This design allows entry of driven shaft from either side of gear housing.

Electrical Connection Options

Conduit Box Location

When ordering a conventional OtN gearmotor, specify the desired conduit box location when viewing fan cover guard of motor. If no option is specified, the conduit box location per gearbox mounting will be supplied as shown in the table below.

Output Arrangement	Standard Conduit Box Location
33G, 53G, 63G, 43C, 53C, 63C	F-2
33D, 35D, 36D, 33X, 55X, 66X, 33B, 33C, 34C, 44C, 35C, 36C, 55C, 66C	F-1

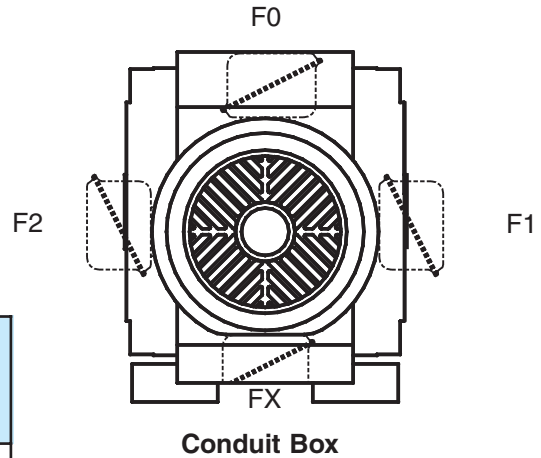

Controller Location

When ordering an IntelliGear Series 2000 or 3000 gearmotor, you can specify the controller location and conduit entry location when viewing the fan cover guard of motor. If no options are specified, the "F0" controller location will be supplied.

* Refer to Application Engineering for de-rating guidance in the F1 or F2 IntelliGear locations.

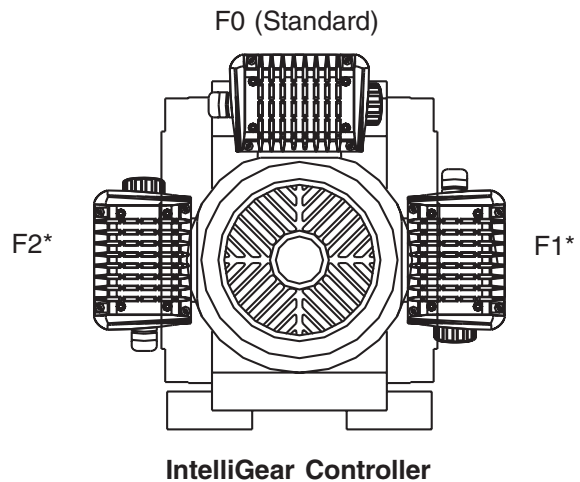

Cable Entry

IntelliGear Cable Entry can be from either side of enclosure. If no option is specified, "A" will be supplied.

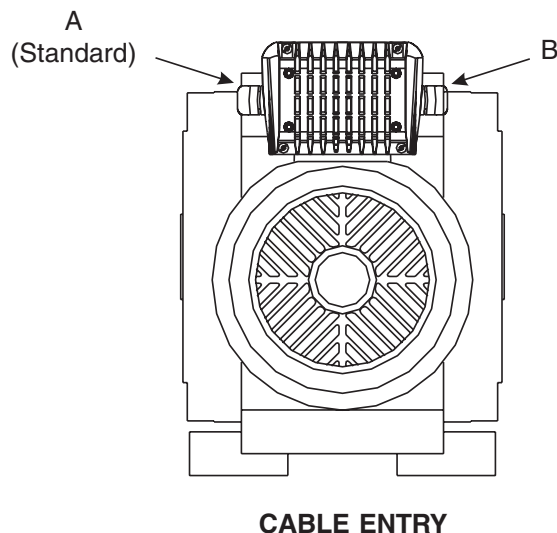

Inverter Duty Gearmotors

Improvements in OtN helical-bevel designs begin with three phase motor designs that now incorporate an upgraded wire and varnish treatment called Allguard. This makes the standard three phase gearmotors suitable for use with inverters in many applications. A one year warranty will be extended for 3:1 (60 - 20 Hz) constant torque for standard efficiency design motors and 4:1 (60 - 15 Hz) constant torque for premium efficiency design motors providing the following conditions are met:

- Motor is non-hazardous 3 phase > 48 frame
- Cable length to controller ≤ 100 ft
- Line voltage is ≤ 480 VAC
- Thermal protection is not required

For all other conditions of operation, including up to 575 VAC and for hazardous location service, select a Varidyne inverter duty motor design. These designs include thermostats in winding, a 3 year warranty on the motor and full compliance with NEMA MG1 Part 31.

Motor Modifications

M1 Brakes

Design

These mounted brakes have a direct acting, spring set, electromagnetically released disc design. When power to the brake motor is interrupted, the brake will set and hold. When power is restored, the brake will automatically release.

Brake torque must be specified when ordering. Table 1 gives brake torque for stopping and holding loads not greater than full load motor torque. An asterisk indicates borderline maximum ratings and should be considered only for holding loads. Refer applications involving high inertia loads or frequent starts and stops to Application Engineering for review.

Enclosures

Standard - Suitable for most indoor, non-hazardous applications. Stock shur-stop brakes have this enclosure.

Waterproof/dust-tight - For applications requiring additional brake protection such as washdown or Corro-Duty. Not suitable for hazardous Class 2 dust applications. Subject to production lead time.

Explosionproof - When a brake is to be mounted on an explosionproof gearmotor, the brake must have UL approval equal to that of the motor end. Brakes are rated class I group D, class II groups F & G temperature code T3B. Subject to production lead-time. Refer all 56, 140T motor frame requirements for explosionproof brakes to Application Engineering before quoting.

Operating Voltage

Production brakes through 15 lb. ft. are supplied with 230/460 volt coils. Brakes 25 lb. ft. and larger are supplied with 460 volt coils. For brakes to operate at a different frequency or voltage, or for brakes to operate from a separate power supply, refer to Emerson Power Transmission Application Engineering. Brakes are furnished with leads suitable for external connection.

Mounting

Brakes listed in Table 1 are motor mounted. Brakes through 6 lb. ft. are suitable for all mounting positions. For brakes 10 through 35 lb. ft., specify mounting orientation of brake gearmotor. Where vertical mounting of brakes 50 lb. ft. or larger is required, refer to Emerson Power Transmission Application Engineering with mounting and application details.

TABLE 1

Max. HP Ratings - High Speed Input				Brake
4 Pole 1800 rpm	4 Pole 1500 rpm	6 Pole 1200 rpm	6 Pole 1000 rpm	Torque (ft-lbs)
1	3/4	1/2	1/2	3
2	1 1/2	1	1	6
3	2	2	1 1/2*	10
5	3	3	2	15
7 1/2	5	5	3	25
10	10*	7 1/2	5	35
15	10	10	7 1/2	50
20	20*	15	10	70
25	20	15	10	75
30	30*	20	20*	105
40	30	25	20	125
50	40	40*	30	175

*Indicates borderline maximum rating for holding loads only.

Motor Modifications Continued

M2 Premium Efficiency

Premium efficiency motor designs are available starting at 1 HP to meet customer specifications or NRCAN legislation. Corro-Duty motors \geq 3 HP and all inverter duty motors meet premium efficiency requirements as standard. TEFC and Corro-Duty motor ends from 1 through 2 HP are design C and therefore are exempt from NRCAN efficiency requirements.

M3 Multi-Speed (3 Phase Only)

Gearmotors with 1800 RPM motors as standard can be supplied with two speed, one winding, constant torque, 1800/900 RPM, 1.0 service factor, TEFC motor ends. Note that change in motor frame may change gearbox size. Thus if gear frame is not within allowable range, it may be necessary to change gear frame size.

TABLE 2

HP	Frame	Allowable Gear Frames
.33 / .16	56	Sizes 2-5 3-Stage Sizes 2-8 5-Stage or 6-Stage
.50 / .25	56	Sizes 2-5 3-Stage Sizes 2-8 5-Stage or 6-Stage
.75 / .38	143T	Sizes 2-5 3-Stage Sizes 2-8 5-Stage or 6-Stage
1.0 / .50	145T	Sizes 2-5 3-Stage Sizes 2-8 5-Stage or 6-Stage
1.5 / .75	145TY	Sizes 2-5 3-Stage Sizes 2-8 5-Stage or 6-Stage
2.0 / 1.0	182T	Sizes 2-7 3-Stage Sizes 3-8 5-Stage or 6-Stage
3.0 / 1.5	184T	Sizes 2-7 3-Stage Sizes 3-8 5-Stage or 6-Stage
5.0 / 2.5	215T	Sizes 3-8 3-Stage Sizes 6-8 5-Stage or 6-Stage
7.5 / 3.75	254T	Sizes 4-8 3-Stage Sizes 6-8 5-Stage or 6-Stage
10 / 5	256T	Sizes 4-8 3-Stage Sizes 6-8 5-Stage or 6-Stage
15 / 7.5	284T	Sizes 5-8 3-Stage Size 8 5-Stage or 6-Stage
20 / 10	286T	Sizes 5-8 3-Stage Size 8 5-Stage or 6-Stage
25 / 12.5	324T	Sizes 7-8 3-Stage
30 / 15	326T	Sizes 7-8 3-Stage

M4 Canopy Cap

A canopy cap can be supplied for protection from dripping liquids entering fan end of gearmotor when mounted in a motor fan up position (V5).

Motor Modifications Continued

M5 Frequency - 50 Hz

Motors for operation at 3 phase 50 Hz are available. Standard 50 Hz voltage (detailed in M6) do not require voltage modification. The published output speed, based on 1750 RPM input, will be reduced by a factor of (1.2) at the same gear ratio. Example: 100 RPM output, 60 Hz, 1750 RPM input is 83 RPM output, 50 Hz, 1450 RPM input.

M6 Voltage (3 Phase Only)

Standard voltages are listed in the table below. Other voltages are available and must be specified at order entry and require special voltage adder.

Frequency	3 Phase Voltages Through 30 HP
60 Hz	200, 230, 230/460, 460, 575
50 Hz	200, 220, 230, 220/380, 220/440, 380, 415, 460, 500, 575

M7 Insulation

Standard 3 phase TEFC and Corro-Duty motor ends have premium Q3 class F insulation standard. Single phase TEFC and explosionproof motor ends have class B insulation as standard. Class H insulation and tropical protection are available from production on 3 phase motors only (class H not available on explosionproof).

M8 Space Heaters

Space heaters are recommended for gearmotors installed in damp locations to prevent condensation on the motor windings when the motor is not operating. Leads are brought to the standard motor conduit box. Space heater voltage (115, 230, 460 volts) must be specified when the order is entered.

M9 Thermal Protection - Thermostats

This protection uses a bi-metal disc thermostat, embedded in the motor winding, connected into the holding circuit of the motor starter. The sensor opens the control circuit, shutting down the motor on over temperature. Thermostats give protection for running overload, abnormally high ambient, voltage unbalance, high or low voltage and ventilation failure. Thermostats will not give protection for locked rotor, starting overload and single phasing.

M10 Thermal Protection - Therma-Sentry

Therma-Sentry is a full protection system that consists of a solid state electronic controller and thermistor temperature sensors embedded in the motor winding. In addition to all the protections provided by a thermostat, Therma-Sentry also protects against locked rotor, starting overload and single phasing. The Therma-Sentry system requires only two leads to connect to the starter panel. The Therma-Sentry controller is supplied loose to be separately mounted and separately excited.

Gearmotor Modifications

M11 Corro-Duty

Corro-Duty gearmotors are designed for applications in food processing, chemical, poultry and any other industries that will be subjected to extreme humidity, washdown, steam, detergents and mild acids. Construction of Corro-Duty gearmotors begins with a Corro-Duty cast iron motor (56 and 140T frames are rolled steel) and normally closed breather in the gear case. The exterior of the entire unit is then painted in one of the two options chosen at order entry.

Option #1 - Corro-Duty grey

- 3 step paint system using 316 stainless steel paint
- Light grey semigloss finish
- USDA and FDA approved

Option #2 - Corro-Duty white

- 2 step paint system using epoxy paint
- White gloss finish
- USDA and FDA approved

M12 Normally Closed Breather

This breather protects against lubricant contamination in applications with flying dust, lint or washdown. A normally closed breather is standard on frames sizes 2 through 5, or it may be added to frames 6 through 8 by specifying this option.

M13 NPT Adapter

These adapters convert metric threads of breather, drain and/or oil level holes in the reducer to standard NPT threads. They are required for customer additions of site glasses, sight tubes, special breathers and other plumbing accessories. The adapter(s) is supplied loose for mounting by others.

Gear Frame	Size	Part Number
2 - 5	1/4" NPFT	0436216
6 - 8	3/4" NPFT	0436218

M15 Export Boxing

Export boxing can be provided for "underdeck" transport. When the quantity of OtN gearmotors exceeds five units, refer to the sales department for the most economical accommodations.

M16 Special Nameplate

Units can be provided with limited, additional, special information on the standard product nameplate. When requested, a special nameplate may be provided and stamped with custom markings.

Gearmotor Modifications

M18 Oil Level View Port

This clear port is installed in place of the oil level plug. It allows maintenance personnel a convenient means of checking for proper oil level without removing plugs. Proper View Port part numbers are:

Gear Frame	Size	Part Number
2 - 5	1/4" BSPP Male	0435936
6 - 8	3/4" BSPP Male	0435938

Face and Flanged Output

(Designated under Brackets and Shafts)

Gearmotors with faced or flanged outputs are available from stock. Refer to page B-14 and individual dimension pages for options available based on gear frame size.

Synthetic Oil

OtN gearmotors are supplied factory-filled with a premium synthetic oil. Refer to page B-187 for complete details of lubricants.

Torque Reaction Arm

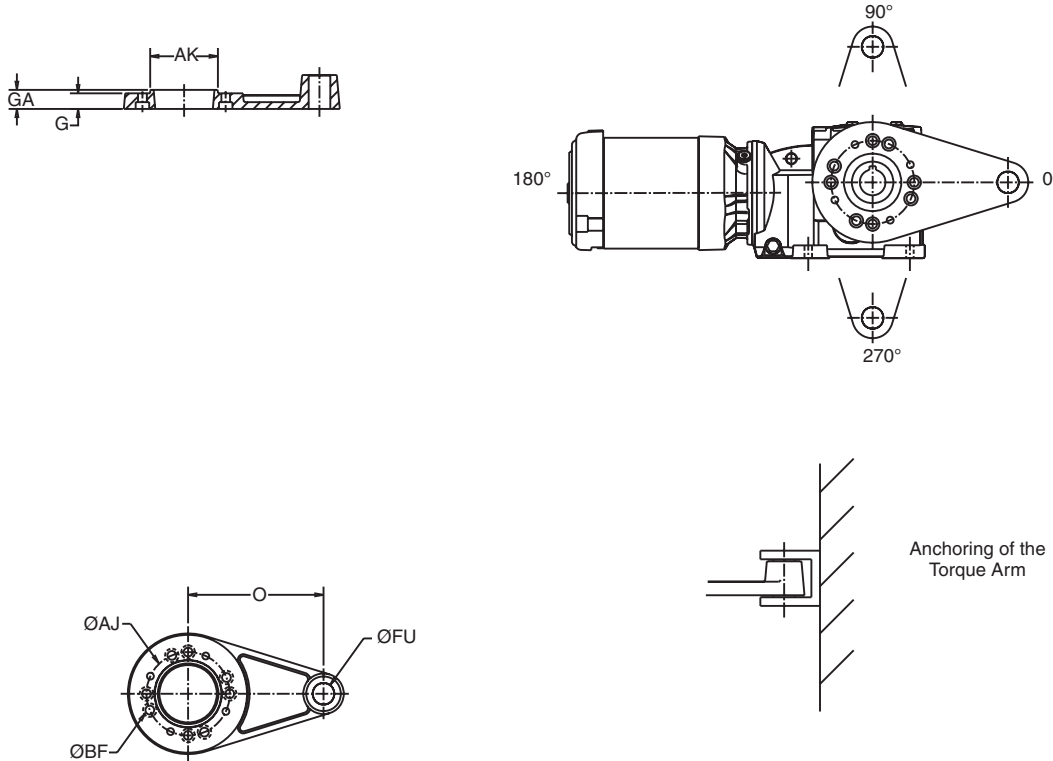

- Torque arm can be assembled in any of the three positions shown in the drawing above relative to the input (motor) when called out on the order.
- If torque arm is requested on an assembly order and no mounting position is called for, the default position is 0°.
- Torque arm can be affixed to either side of the 33C or 33B gear housing.

Series 3000

OtN Frame	Part ID # Kit	G	O	AJ	AK	BF	FU	GA
32	ROC200KT001	.63	5.118	3.94	3.150	.43	.87	.79
33	ROC300KT001	.91	7.874	4.84	3.937	.51	1.260	1.10
34	ROC400KT001	-	9.842	5.98	5.118	.51	1.260	.91
35	ROC500KT001	-	12.205	7.48	6.102	.67	1.260	.98

Torque Reaction Arm

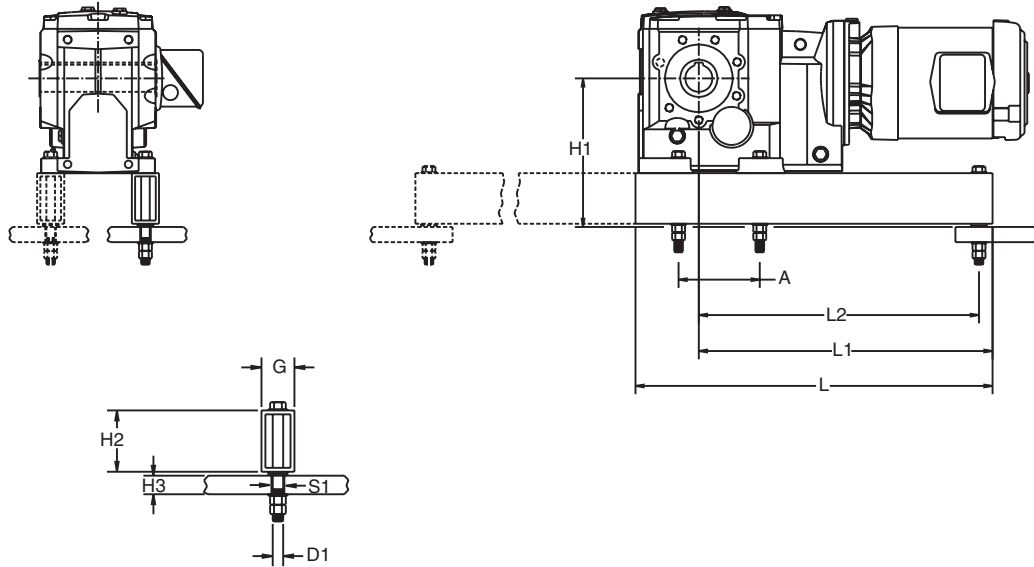

- Torque arm can be assembled with attachment point on the input side or 180° opposite this, as shown above.
- Torque arm can be attached onto feet on either side of the gear housing as you face opposite the input (motor).

Series 2000

Gear Frame	Part Number	A	D1	G	H1	H2	H3 max.	L	L1	L2	S1 min.
26	0986479	13.98	.75	2.50	13.61	4.50	1.50	35.83	27.46	26.08	0.81
27	0986479	16.54	.75	2.50	14.59	4.50	1.50	35.83	26.18	24.80	0.81
28	0986480	20.08	.88	4.00	18.67	6.00	1.88	43.31	31.69	30.12	0.94

Each Series 3000 OtN can be ordered with a Tapered Bushed Output. This “33B” mounting configuration will include the appropriate bushing kit unassembled when a bore is defined at order entry. The table below shows the various stocked bushing bores for each OtN frame that can be specified. Each bushing kit is supplied with bushing, hardware for mounting and a stabilizer ring. If bushings are required as a spare or bore changed in the field, refer to the OtN 3000 frame and select the required kit from below.

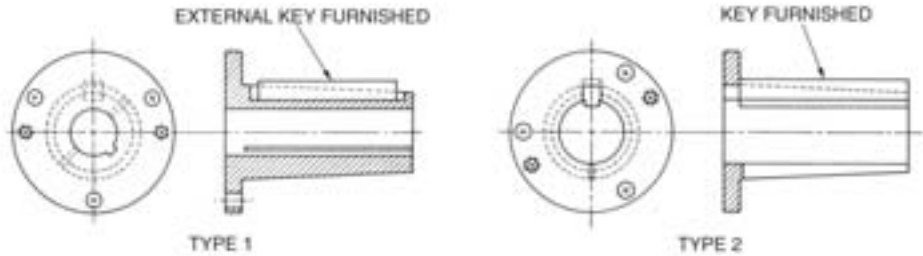
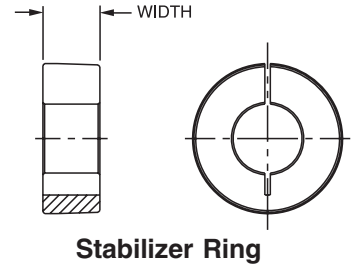

OtN Frame	Mea. Unit	Bushing No.	Bore	Shaft Keyseat Required	Type	Stabilizer Ring Width	Bolt Torque		Weight (lbs.)	
							Bolt Size	Ft.-lbs.		
32 33	Inch	107TBP012	3/4	3/16 x 3/32 x 3 7/8	1	0.793	5/16 -18 x 1 1/4	16	2.6	
		107TBP014	7/8	3/16 x 3/32 x 3 7/8	1				2.5	
		107TBP015	15/16	1/4 x 1/8 x 3 7/8	2				2.4	
		107TBP100	1	1/4 x 1/8 x 3 7/8	2				2.3	
		107TBP101	1 1/16	1/4 x 1/8 x 3 7/8	2				2.1	
		107TBP102	1 1/8	1/4 x 1/8 x 3 7/8	2				2.0	
		107TBP103	1 3/16	1/4 x 1/8 x 3 7/8	2				1.9	
		107TBP104	1 1/4	1/4 x 1/8 x 3 7/8	2				1.8	
		107TBP105	1 5/16	5/16 x 5/32 x 3 7/8	2				1.6	
		107TBP106	1 3/8	5/16 x 5/32 x 3 7/8	2				1.5	
		107TBP107	1 7/16	3/8 x 3/16 x 3 7/8	2				1.5	
		Metric *	107TBP30MM	30 mm	8 x 4 x 94 (mm)				2	1.9
			107TBP35MM	35 mm	10 x 5 x 94 (mm)				2	1.5
		34	Inch	115TBP015	15/16				1/4 x 1/8 x 4 1/8	1
115TBP100	1			1/4 x 1/8 x 4 1/8	1	5.9				
115TBP101	1 1/16			1/4 x 1/8 x 4 1/8	1	5.7				
115TBP102	1 1/8			1/4 x 1/8 x 4 1/8	1	5.6				
115TBP103	1 3/16			1/4 x 1/8 x 4 1/8	1	5.4				
115TBP104	1 1/4			1/4 x 1/8 x 4 1/8	1	5.3				
115TBP105	1 5/16			5/16 x 5/32 x 4 1/8	2	5.1				
115TBP106	1 3/8			5/16 x 5/32 x 4 1/8	2	4.8				
115TBP107	1 7/16			3/8 x 3/16 x 4 1/8	2	4.7				
115TBP108	1 1/2			3/8 x 3/16 x 4 1/8	2	4.4				
115TBP110	1 5/8			3/8 x 3/16 x 4 1/8	2	4.0				
115TBP111	1 11/16			3/8 x 3/16 x 4 1/8	2	3.7				
115TBP112	1 3/4			3/8 x 3/16 x 4 1/8	2	3.5				
115TBP114	1 7/8			1/2 x 1/4 x 4 1/8	2	3.1				
115TBP115	1 15/16			1/2 x 1/4 x 4 1/8	2	2.7				
Metric *	115TBP40MM			40 mm	12 x 5 x 100 (mm)	2	4.0			
	115TBP45MM			45 mm	14 x 5.5 x 100 (mm)	2	3.5			
35	Inch			207TBP106	1 3/8	5/16 X 5/32 x 5 1/8	1	1.040	3/8-16 X 1 1/4	29
		207TBP107	1 7/16	3/8 X 3/16 X 5 1/8	1	9.3				
		207TBP108	1 1/2	3/8 X 3/16 X 5 1/8	1	9.1				
		207TBP110	1 5/8	3/8 X 3/16 X 5 1/8	2	8.5				
		207TBP111	1 11/16	3/8 X 3/16 X 5 1/8	2	8.3				
		207TBP112	1 3/4	3/8 X 3/16 X 5 1/8	2	7.9				
		207TBP114	1 7/8	1/2 X 1/4 X 5 1/8	2	7.3				
		207TBP115	1 15/16	1/2 X 1/4 X 5 1/8	2	6.9				
		207TBP200	2	1/2 X 1/4 X 5 1/8	2	6.6				
		207TBP202	2 1/8	1/2 X 1/4 X 5 1/8	2	5.9				
		207TBP203	2 3/16	1/2 X 1/4 X 5 1/8	2	5.5				
		207TBP204	2 1/4	1/2 X 1/4 X 5 1/8	2	5.1				
		207TBP207	2 7/16	5/8 X 5/16 X 5 1/8	2	3.9				
		Metric *	207TBP50MM	50 mm	14 x 5.5 x 125 (mm)	2	6.6			
			207TBP60MM	60 mm	18 x 7 x 125 (mm)	2	4.5			

* Metric bushings have metric bores and require metric keyseats as shown in mm.

AGMA Application Classifications

U: Uniform load M: Moderate shock load V: Heavy shock load

Application	Load	Class		Application	Load	Class		Application	Load	Class	
		Up to 10 hrs/day	Over 10 hrs/day			Up to 10 hrs/day	Over 10 hrs/day			Up to 10 hrs/day	Over 10 hrs/day
Agitators				Bucket				Conveyors - Uniformly			
Paper Mills	M	II	II	Conveyors, Uniform	U	I	II	Loaded or Fed: Apron, Ass-			
Pure Liquids	U	I	II	Conveyors, Heavy Duty	M	II	II	sembly, Belt, Bucket, Chain,			
Liquids & Solids	M	II	II	Elevators Cont.	U	I	II	Flight, Oven, Screw	U	I	II
Liquids - Variable Density	M	II	II	Elevators Uniform	U	I	II				
				Elevators, Heavy Duty	M	II	II	Conveyors - Heavy Duty			
Apron Conveyors				Calenders				Not Uniformly Fed: Apron,			
Uniformly Loaded or Fed	U	I	II	Paper	U	-	II	Assembly, Belt, Bucket,			
Heavy Duty	M	II	II	Super (Paper)	U	-	II	Chain, Flight, Oven, Screw	M	II	II
Apron Feeders	M	II	II	Rubber	M	II	II	Live Roll (Package)	U	I	II
				Textile	M	II	II	Reciprocating, shaker	V	III	III
Assembly Conveyors				Cane Knives	M	II	II	Cookers (Brewing and			
Uniformly Loaded or Fed	U	I	II					Distiling) (Food)	U	I	II
Heavy Duty	M	II	II	Can Filling Machines	U	I	II				
Ball Mills	V	III	III					Cooling Tower Fans			
				Card Machines (Textile)	M	II	II	Induced Draft	M	II	II
Barking								Forced Draft	Refer to Application Engineering		
Drums	V	-	III	Car Dumpers	V	III	-	Couch (Paper)	M	-	II
Hydraulic Auxiliaries	V	-	III								
Mechanical	V	-	III	Car Pullers	M	II	-	Cranes and Hoists			
Barscreens (Sewage)	U	I	II					Main Hoists			
				Cement Kilns	Refer to Application Engineering			Heavy Duty	V	III	III
Batchers (Textile)	M	II	II					Medium Duty	M	II	II
				Centrifugal				Reversing	V	II	II
Beaters and Pulpers (Paper)	U	-	II	Blowers, Compressors, Dis-	U	I	II	Skip Hoists	M	II	II
				charge Elevators or Pumps				Trolley Drive	M	II	II
Belt Conveyors								Bridge Drive	M	II	II
Uniformly Loaded or Fed	U	I	II	Chain Conveyors				Crushers			
Heavy Duty	M	II	II	Uniformly Loaded or Fed	U	I	II	Ore or Stone	V	III	III
				Heavy Duty	M	II	II				
Belt Feeders	M	II	II	Chemical Feeders (Sewage)	U	I	II	Cutters (Paper)	V	-	III
Bending Rolls (Machine)	M	II	II	Clarifiers	U	I	II	Cylinders (Paper)	M	-	II
Bleachers (Paper)	M	-	II	Classifiers	M	II	II	Dewatering Screens (Sewage)	M	II	II
Blowers				Clay Working Industry				Disc Feeders	U	I	II
Centrifugal	U	I	II	Brick Press	V	III	III				
Lobe	M	II	II	Briquette Machine	V	III	III	Distilling	(See Brewing)		
Vane	U	I	II	Clay Working Machinery	M	II	II				
				Pug Mill	M	II	II	Double Acting Pumps			
Bottling Machinery	U	I	II	Collectors (Sewage)	U	I	II	2 or more Cylinders	M	II	II
								Single Cylinder	Refer to Application Engineering		
Brewing and Distilling				Compressors				Dough Mixer (Food)	M	II	II
Bottling Machinery	U	I	II	Centrifugal	U	I	II				
Brew Kettles, Cont. Duty	U	-	II	Lobe	M	II	II	Draw Bench (Metal Mills)			
Can Filling Machines	U	I	II	Reciprocating,				Carriage & Main Drive	V	III	III
Cookers - Cont. Duty	U	-	II	Multi - Cylinder	M	II	II				
Mash Tubs - Cont. Duty	U	-	II	Single - Cylinder	V	III	III	Dredges			
Scale Hoppers - Frequent Starts	M	II	II					Cable Reels	M	II	-
				Concrete Mixers				Conveyors	M	II	II
Brick Press (Clay Working)	V	III	III	Continuous	M	II	II	Cutter Head Drives	V	III	III
				Intermittent	U	I	-	Jig Drives	V	III	III
Briquetts Machines (Clay Working)	V	III	III	Converting Machines (Paper)	M	-	II	Maneuvering Winches	M	II	-
								Pumps	M	II	II
								Screen Drives	V	III	III
								Stackers	M	II	II
								Utility Winches	M	II	-

OtN Series

AGMA Application Classifications

U: Uniform load M: Moderate shock load V: Heavy shock load

Application	Load	Class		Application	Load	Class		Application	Load	Class	
		Up to 10 hrs/day	Over 10 hrs/day			Up to 10 hrs/day	Over 10 hrs/day			Up to 10 hrs/day	Over 10 hrs/day
Dryers (Paper)	U	-	II	Hammer Mills	V	III	III	Machine Tools			
Dryers and Coolers (Mills, Rotary)	M	II	II	Induced Draft Fans	M	II	II	Auxiliary Drives	U	I	II
Dyeing Machinery (Textile)	M	II	II	Jordans (Paper)	U	-	II	Bending Rolls	M	II	II
Elevators				Kilns (Mills, Rotary) Cement	M	II	II	Main Drives	M	II	II
Bucket - Uniform Load	U	I	II	Refer to Application Engineering				Notching Press (Belted)	Refer to Application Engr.		
Bucket - Heavy Duty	M	II	II	Laundry Washers and Tumblers	M	II	II	Plate Planers	V	III	III
Bucket - Continuous	U	I	II	Line Shafts				Punch Press (Geared)	V	III	III
Centrifugal Discharge	U	I	II	Heavy Shock Load	V	III	III	Tapping Machines	V	III	III
Escalators	U	I	II	Moderate Shock Load	M	II	II				
Freight	M	II	II	Uniform Load	U	I	II	Mangle (Textile)	M	II	II
Gravity Discharge	U	I	II	Live Roll Conveyors				Mash Tubs (Brewing and Distilling)	U	-	II
Man Lifts, Passenger	Refer to Application Engineering			Package	U	I	II	Meat Grinder (Food)	M	II	II
Escalators	U	I	II	Lobe Blower or Compressors	M	II	II	Metal Mills			
Fans				Log Hauls (Paper and Lumber)	V	III	III	Draw Bench Carriages & Main Drives	V	III	III
Centrifugal	M	II	II	Looms (Textile)	M	II	II	Forming Machines	V	III	III
Cooling Towers				Lumber Industry				Pinch, Dryer & Scrubber			
Induced Draft	M	II	II	Barkers - Spindle Feed	V	II	III	Rolls Reversing	Refer to Application Engineering		
Forced Draft	Refer to Application Engineering			Barkers - Main Drive	V	III	III	Slitters	M	II	II
Induced Draft	M	II	II	Carriage Drive	Refer to Application Engineering			Table Conveyors, Non-Reversing	M	II	III
Large (Mine, etc.)	M	II	II	Conveyors				Reversing	V	-	III
Large Industrial	M	II	II	Burner	V	II	III	Wire Drawing & Flattening Machines	M	II	III
Light (Small Diameter)	U	I	II	Main or Heavy Duty	V	II	III	Wire Winding Machines	M	II	II
Feeders				Main Log	V	III	III				
Apron, belt	M	II	II	Re-Saw Merry-Go-Round	V	II	III	Mills, Rotary Type			
Disc	U	I	II	Slab	V	III	III	Ball, Pebble, Rod	V	III	III
Reciprocating	V	III	III	Transfer	V	II	III	Cement Kilns	Refer to Application Engineering		
Screw	M	II	II	Chains - Floor	V	II	III	Coolers, Dryers, Kilns	V	II	II
Felt				Chains - Green	V	II	III	Tumbling Barrels	V	III	III
Stretchers (Paper)	U	-	II	Cut-Off Saws-Chain	V	II	III				
Whippers (Paper)	U	-	II	Cut-Off Saws-Drum	V	II	III	Mixers (Also see Agitators)			
Flight				Debarking Drums	V	III	III	Concrete - Continuous	M	II	II
Conveyors, Uniform	U	I	II	Feeds - Edger	V	II	III	Concrete - Intermittent	M	I	-
Conveyors, Heavy	M	II	II	Feeds - Gang	V	III	III	Constant Density	U	I	II
Food Industry				Feeds - Trimmer	V	II	III	Variable Density	M	II	II
Beet Slicers	M	II	II	Log Deck	V	III	III				
Bottling, Can Filling Mach.	U	I	II	Log Hauls - Incline, Well Type	V	III	III	Nappers (Textile)	M	II	II
Cereal Cookers	U	I	II	Log Turning Devices	V	III	III	Oil Industry			
Dough Mixers	M	II	II	Planner Feed	V	II	III	Chillers	M	II	II
Meat Grinders	M	II	II	Planer Tilting Hoists	V	II	III	Oil Well Pumping	Refer to Application Engineering		
Forming Machines (Metal Mills)	V	III	III	Rolls - Live-Off Bearing				Paraffin Filter Press	M	II	II
Generators (Not welding)	U	I	II	Roll Cases	V	III	III	Rotary Kilns	M	II	II
Gravity Discharge Elevators	U	I	II	Sorting Table	V	II	III	Ore Crushers	V	III	III
Grit Collectors (Sewage)	U	I	II	Tipple Hoist	V	II	III	Oven Conveyors			
				Transfers - Chain	V	II	III	Uniform	U	I	II
				Transfers - Craneway	V	II	III	Heavy Duty	M	II	II
				Tray Drives	V	II	III				

OtN Series

AGMA Application Classifications

U: Uniform load M: Moderate shock load V: Heavy shock load

Application	Load	Class		Application	Load	Class		Application	Load	Class	
		Up to 10 hrs/day	Over 10 hrs/day			Up to 10 hrs/day	Over 10 hrs/day			Up to 10 hrs/day	Over 10 hrs/day
Paper Mills				Rod Mills	V	III	III	Soapers (Textile)	M	II	II
Agitator (Mixers)	M	II	II	Rotary				Spinners (Textile)	M	II	II
Barker - Auxiliaries - Hyd.	V	-	III	Pumps, Gear, Lobe, Vane	U	I	II	Steering Gears	M	II	II
Barker, Mechanical	V	-	III	Screens (Sand or Gravel)	V	II	II	Stock Chests(Paper)	U	-	ii
Barking Drum	V	-	III	Rubber Industry				Stokers	U	I	II
Beater & Pulper	M	-	II	Mixer	V	III	III	Stone Crushers	V	III	III
Bleacher	M	-	II	Rubber Calender	M	II	II	Suction Rolls(Paper)	U	-	II
Calenders	M	-	II	Rubber Mill (2 or more)	M	II	II	Table Conveyors			
Calenders - Super	M	-	II	Sheeter	M	II	II	(Metal Mills) Non-Reversing	V	II	III
Converting Mach.-				Tire Building Machines	Refer to Application Engr.			Reversing	V	-	III
Except Cutters - Platers	M	-	II	Tire, Tube Press Openers	Refer to Application Engr.			Tenter Frames			
Conveyors	M	-	II	Tubers & Strainers	M	II	II	(Textile)	M	II	II
Couch	M	-	II	Sand Mullers	Refer to Application Engr.			Textile Industry			
Cutters, Platers	V	-	III	Screens				Batchers	M	II	II
Cylinders	U	-	II	Air Washing	U	I	II	Calenders	M	II	II
Dryers	U	-	II	Rotary - Sand or Gravel	M	II	II	Card Machines	M	II	II
Felt Stretchers	U	-	II	Traveling Water Intake	U	I	II	Cloth Finishing Mach. (Cal-			
Felt Whippers	V	-	III	Screw Conveyors				enders, Dryers, Pads,			
Jordans	M	-	II	Uniform	U	I	II	Tenters, Washers)	M	II	II
Log Haul	V	-	III	Heavy Duty or Feeder	M	II	II	Dry Cans	M	II	II
Presses	M	-	II	Scum Breakers				Dyeing Machinery	M	II	II
Pulp Machine Reels	M	-	II	(Sewage)	M	II	II	Knitting Machinery	Refer to Application Engr.		
Stock Chests	M	-	II	Sewage Disposal				Looms, Mangles, Nappers	M	II	II
Suction Rolls	M	-	II	Aerators	Refer to Application Engineering			Range Drives	Refer to Application Engr.		
Washers & Thickeners	M	-	II	Bar Screens	U	I	II	Soapers, Spinners	M	II	II
Winders	M	-	II	Chemical Feeders	U	I	II	Tenter Frames	M	II	II
Passenger Elevators	Refer to Application Engineering			Collectors	U	I	II	Winders	M	II	II
Pebble Mills	V	III	III	Dewatering Screens	M	II	II	Yarn Preparatory Mach.			
Plate Planers	V	III	III	Grit Collectors	U	I	II	(Cards, Spinners, Slashers)	M	II	II
Presses (Paper)	V	-	III	Scum Breakers	M	II	II	Thickeners (Sewage)	M	II	II
Proportioning Pumps	M	II	II	Slow or Rapid Mixers	M	II	II	Tumbling Barrels	V	III	III
Pub Mills (Clay)	M	II	II	Sludge Collectors	U	I	II	Vacuum Filters			
Pullers (Barge Haul)	V	III	III	Thickeners	M	II	II	(sewage)	M	II	II
Pulp Machine Reels	U	-	II	Vacuum Filters	M	II	II	Vane Blowers	U	I	II
Pumps				Shaker Conveyors	V	III	III	Winches (Dredges)	M	II	-
Centrifugal	U	I	II	Sheeters (Rubber)	M	II	II	Winders			
Proportioning	M	II	II	Singls Acting Pump				(Paper)	U	-	II
Reciprocating				1 or 2 Cylinders	Refer to Application Engineering			(Textile)	M	II	II
Single Act., 3 or more cyl.	M	II	II	3 or more Cylinders	M	II	II	Windlass	M	II	II
Double Act., 2 or more cyl.	M	II	II	Skip Hoist	M	II	II	Wire			
Single Act., 1 or 2 cyl.	Refer to Application Engr.			Slab Pushers	M	II	II	Drawing Machines	M	II	III
Rotary: Gear, Lobe, Vane	U	I	II	Slitters (Metal)	M	II	II	Winding Machines	M	II	II
Punch Press				Sludge Collectors							
(Gear Driven)	V	III	III	(Sewage)	U	I	II				
Reciprocating											
Conveyors, Feeders	V	III	III								
Reciprocating Compressors											
Multi-Cylinder	M	II	II								
Single cylinder	V	III	III								

OtN Series

Applications not listed in this table, or where the user has data indicating the severity of this usage to be greater than average, should be referred to Application Engineering.

General Specifications: Totally enclosed, 60 hertz, 40°C ambient, continuous duty.

Output rpm	AGMA Class	Service Factor	Output Torque in-lb	OHL Δ lb	Nominal Ratio	Frame Size Gear	Motor	Std. Motor Types ◇
179	I, II, III	3+	55	1163	10	3243	48	T,S
141	I, II, III	3+	70	1250	12.5	3243	48	T,S
126	I, II, III	3+	79	1295	14	3243	48	T,S
109	I, II, III	3+	91	1254	16	3243	48	T,S
105	I, II, III	3+	94	1367	18	3243	48	T,S
86	I, II, III	3+	115	1456	20	3243	48	T,S
76	I, II, III	3+	129	1490	22.4	3243	48	T,S
73	I, II, III	3+	136	1490	25	3243	48	T,S
64	I, II, III	3+	154	1490	28	3243	48	T,S
57	I, II, III	3+	174	1490	31.5	3243	48	T,S
50	I, II, III	3+	197	1490	35.5	3243	48	T,S
44	I, II, III	3+	223	1490	40	3243	48	T,S
39	I, II, III	3+	255	1490	45	3243	48	T,S
34	I, II, III	3+	288	1490	50	3243	48	T,S
32	I, II, III	3+	306	1490	56	3243	48	T,S
27	I, II, III	3+	363	1490	63	3243	48	T,S
26	I, II, III	3+	384	1490	71	3243	48	T,S
23	I, II, III	3+	439	1490	80	3243	48	T,S
20	I, II, III	3+	490	1490	90	3243	48	T,S
18	I, II, III	3+	549	1490	100	3243	48	T,S
15	I, II, III	3+	638	1490	112	3243	48	T,S
14	I, II, III	3+	701	1490	125	3243	48	T,S
12	I, II, III	3+	802	1490	140	3243	48	T,S
11	I, II, III	3+	881	1490	160	3243	48	T,S

Refer to Application Engineering for speeds slower than shown.

◇ **Standard Motor Types** (see page B-15 for product codes)

T TEFC, three phase, 208-230/460 or 575 volts

S TEFC, single phase, 115/230 volts

Δ Overhung load rating is at shaft midpoint.

General Specifications: Totally enclosed, 60 hertz, 40°C ambient, continuous duty.

Output rpm	AGMA Class	Service Factor	Output Torque in-lb	OHL Δ lb	Nominal Ratio	Frame Size Gear	Motor	Std. Motor Types ◇
179	I, II, III	3+	83	1141	10	3243	48	T,S
141	I, II, III	3+	105	1228	12.5	3243	48	T,S
126	I, II, III	3+	118	1273	14	3243	48	T,S
109	I, II, III	3+	136	1332	16	3243	48	T,S
105	I, II, III	3+	141	1355	18	3243	48	T,S
86	I, II, III	3+	173	1434	20	3243	48	T,S
76	I, II, III	3+	194	1485	22.4	3243	48	T,S
73	I, II, III	3+	204	1490	25	3243	48	T,S
64	I, II, III	3+	231	1490	28	3243	48	T,S
57	I, II, III	3+	261	1490	31.5	3243	48	T,S
50	I, II, III	3+	295	1490	35.5	3243	48	T,S
44	I, II, III	3+	335	1490	40	3243	48	T,S
39	I, II, III	3+	383	1490	45	3243	48	T,S
34	I, II, III	3+	432	1490	50	3243	48	T,S
32	I, II, III	3+	458	1490	56	3243	48	T,S
27	I, II, III	3+	545	1490	63	3243	48	T,S
26	I, II, III	3+	576	1490	71	3243	48	T,S
23	I, II, III	3+	658	1490	80	3243	48	T,S
20	I, II, III	3+	735	1490	90	3243	48	T,S
18	I, II, III	3+	824	1490	100	3243	48	T,S
15	I, II, III	3+	958	1490	112	3243	48	T,S
14	I, II, III	3+	1051	1490	125	3243	48	T,S
12	I, II, III	3+	1203	1490	140	3243	48	T,S
11	I, II, III	3+	1322	1490	160	3243	48	T,S

OtN Series

Refer to Application Engineering for speeds slower than shown.

◇ **Standard Motor Types** (see page B-15 for product codes)
 T TEFC, three phase, 208-230/460 or 575 volts
 S TEFC, single phase, 115/230 volts
 Δ Overhung load rating is at shaft midpoint.

General Specifications: Totally enclosed, 60 hertz, 40°C ambient, continuous duty.

Output rpm	AGMA Class	Service Factor	Output Torque in-lb	OHL Δ lb	Nominal Ratio	Frame Size Gear	Motor	Std. Motor Types ◇
179	I, II, III	3+	110	1119	10	3243	56	T,C,S,X,IG
141	I, II, III	3+	139	1206	12.5	3243	56	T,C,S,X,IG
126	I, II, III	3+	155	1251	14	3243	56	T,C,S,X,IG
109	I, II, III	3+	180	1310	16	3243	56	T,C,S,X,IG
105	I, II, III	3+	186	1323	18	3243	56	T,C,S,X,IG
86	I, II, III	3+	228	1412	20	3243	56	T,C,S,X,IG
76	I, II, III	3+	256	1463	22.4	3243	56	T,C,S,X,IG
73	I, II, III	3+	270	1487	25	3243	56	T,C,S,X,IG
64	I, II, III	3+	305	1490	28	3243	56	T,C,S,X,IG
57	I, II, III	3+	345	1490	31.5	3243	56	T,C,S,X,IG
50	I, II, III	3+	389	1490	35.5	3243	56	T,C,S,X,IG
44	I, II, III	3+	442	1490	40	3243	56	T,C,S,X,IG
39	I, II, III	3+	506	1490	45	3243	56	T,C,S,X,IG
34	I, II, III	3+	570	1490	50	3243	56	T,C,S,X,IG
32	I, II, III	3+	605	1490	56	3243	56	T,C,S,X,IG
27	I, II, III	3+	719	1490	63	3243	56	T,C,S,X,IG
26	I, II, III	3+	761	1490	71	3243	56	T,C,S,X,IG
23	I, II, III	3+	869	1490	80	3243	56	T,C,S,X,IG
20	I, II, III	3+	970	1490	90	3243	56	T,C,S,X,IG
18	I, II, III	3+	1087	1490	100	3243	56	T,C,S,X,IG
15	I, II, III	3+	1264	1490	112	3243	56	T,C,S,X,IG
14	I, II, III	2.9	1387	1490	125	3243	56	T,C,S,X,IG
12	I, II, III	2.5	1588	1490	140	3243	56	T,C,S,X,IG
11	I, II, III	2.3	1745	1490	160	3243	56	T,C,S,X,IG
10.1	I, II, III	3+	1869	2090	180	3365	56	T,C,S,X,IG
9.8	I, II, III	2.1	1912	1490	180	3245	56	T,C,S,X°,IG
9.4	I, II	1.9	2093	1490	125	3243	56 †	T,C,X
8.9	I, II, III	3+	2106	2090	200	3365	56	T,C,S,X,IG
8.9	I, II	1.9	2116	1490	200	3245	56	T,C,S,X°,IG
8.5	I, II, III	3+	2312	2090	140	3363	56 †	T,C,X
8.5	I, II	1.8	2224	1490	224	3245	56	T,C,S,X°,IG
8.2	I, II	1.7	2396	1490	140	3243	56 †	T,C,X
7.9	I, II, III	3+	2385	2090	224	3365	56	T,C,S,X,IG
7.4	I, II	1.5	2633	1490	160	3243	56 †	T,C,X
7.3	I, II, III	2.7	2700	2090	160	3363	56 †	T,C,X
7.1	I, II	1.5	2643	1490	250	3245	56	T,C,S,X°,IG
6.9	I, II, III	2.6	2707	2090	250	3365	56	T,C,S,X,IG
6.7	I, II	1.4	2825	1490	280	3245	56	T,C,S,X°,IG
6.1	I, II, III	2.3	3094	2090	280	3365	56	T,C,S,X,IG

◇ **Standard Motor Types** (see page B-15 for product codes)

T TEFC, three phase, 208-230/460 or 575 volts

S TEFC, single phase, 115/230 volts

C Corro-Duty, three phase, 230/460 or 575 volts

X° Explosionproof, CL1 group D, three phase, 230/460 or 575 volts

X Explosionproof, Cl 1 group D, Cl 2 groups F&G, three phase, 230/460 or 575 volts

IG IntelliGear variable speed for 1-ph/115V, 1-ph/230V, 3-ph/230V, or 3-ph/460V power supplies, NEMA 4/12

Δ Overhung load rating is at shaft midpoint.

† Denotes 6-pole (1200 rpm) motor.

1/3 HP (Continued)

General Specifications: Totally enclosed, 60 hertz, 40°C ambient, continuous duty.

Output rpm	AGMA Class	Service Factor	Output Torque in-lb	OHL Δ lb	Nominal Ratio	Frame Size Gear	Motor	Std. Motor Types ◇
5.9	I	1.2	3169	1490	315	3245	56	T,C,S,X°,IG
5.4	I, II, III	2.0	3491	2090	315	3365	56	T,C,S,X,IG
5.1	I	1.1	3685	1490	355	3245	56	T,C,S,X°,IG
5.1	I, II	1.9	3706	2090	355	3365	56	T,C,S,X,IG
4.7	I	1.0	3975	1490	400	3245	56	T,C,S,X°,IG
4.5	I, II, III	3+	4147	2875	400	3475	56	T,C,S,X,IG
4.3	I, II	1.6	4405	2090	400	3365	56	T,C,S,X,IG
4.0	I, II	1.5	4662	2090	450	3365	56	T,C,S,X,IG
4.0	I, II, III	3+	4695	2875	450	3475	56	T,C,S,X,IG
3.6	I, II, III	2.8	5178	2875	500	3475	56	T,C,S,X,IG
3.5	I	1.3	5329	2090	500	3365	56	T,C,S,X,IG
3.2	I, II, III	2.4	5887	2875	560	3475	56	T,C,S,X,IG
3.2	I	1.2	5941	2090	560	3365	56	T,C,S,X,IG
2.8	I	1.1	6661	2090	630	3365	56	T,C,S,X,IG
2.8	I, II, III	2.1	6725	2875	630	3475	56	T,C,S,X,IG
2.5	I, II	1.9	7595	2875	710	3475	56	T,C,S,X,IG
2.4	I, II, III	2.9	7961	4100	800	3585	56	T,C,S,X,IG
2.3	I, II	1.8	8057	2875	800	3475	56	T,C,S,X,IG
2.0	I, II, III	2.5	9303	4100	900	3585	56	T,C,S,X,IG
2.0	I, II	1.5	9572	2875	900	3475	56	T,C,S,X,IG
1.9	I, II	1.4	10120	2875	1000	3475	56	T,C,S,X,IG
1.8	I, II, III	2.2	10485	4100	1000	3585	56	T,C,S,X,IG
1.6	I, II, III	2.0	11871	4100	1120	3585	56	T,C,S,X,IG
1.5	I	1.1	12730	2875	1120	3475	56	T,C,S,X,IG
1.4	I, II	1.7	13482	4100	1250	3585	56	T,C,S,X,IG
1.3	I, II	1.7	14170	4100	1400	3585	56	T,C,S,X,IG
1.3	I	1.0	14557	2875	1250	3475	56	T,C,S,X,IG
1.2	I, II	1.5	16104	4100	1600	3585	56	T,C,S,X,IG
1.0	I	1.3	18403	4100	1800	3585	56	T,C,S,X,IG
0.91	I	1.1	20766	4100	2000	3585	56	T,C,S,X,IG
0.85	I	1.1	22034	4100	2240	3585	56	T,C,S,X,IG

OtN Series

◇ **Standard Motor Types** (see page B-15 for product codes)

T TEFC, three phase, 208-230/460 or 575 volts

S TEFC, single phase, 115/230 volts

C Corro-Duty, three phase, 230/460 or 575 volts

X° Explosionproof, CL1 group D, three phase, 230/460 or 575 volts

X Explosionproof, Cl 1 group D, Cl 2 groups F&G, three phase, 230/460 or 575 volts

IG IntelliGear variable speed for 1-ph/115V, 1-ph/230V, 3-ph/230V, or 3-ph/460V power supplies, NEMA 4/12

Δ Overhung load rating is at shaft midpoint.

† Denotes 6-pole (1200 rpm) motor.

General Specifications: Totally enclosed, 60 hertz, 40°C ambient, continuous duty.

Output rpm	AGMA Class	Service Factor	Output Torque in-lb	OHL Δ lb	Nominal Ratio	Frame Size Gear	Motor	Std. Motor Types ◇
179	I, II, III	3+	166	1108	10	3243	56	T,C,S,X,IG
141	I, II, III	3+	210	1193	12.5	3243	56	T,C,S,X,IG
126	I, II, III	3+	236	1236	14	3243	56	T,C,S,X,IG
109	I, II, III	3+	273	1293	16	3243	56	T,C,S,X,IG
105	I, II, III	3+	281	1305	18	3243	56	T,C,S,X,IG
86	I, II, III	3+	346	1389	20	3243	56	T,C,S,X,IG
76	I, II, III	3+	388	1438	22.4	3243	56	T,C,S,X,IG
73	I, II, III	3+	408	1461	25	3243	56	T,C,S,X,IG
64	I, II, III	3+	463	1490	28	3243	56	T,C,S,X,IG
57	I, II, III	3+	522	1490	31.5	3243	56	T,C,S,X,IG
50	I, II, III	3+	590	1490	35.5	3243	56	T,C,S,X,IG
44	I, II, III	3+	669	1490	40	3243	56	T,C,S,X,IG
39	I, II, III	3+	766	1490	45	3243	56	T,C,S,X,IG
34	I, II, III	3+	864	1490	50	3243	56	T,C,S,X,IG
32	I, II, III	3+	917	1490	56	3243	56	T,C,S,X,IG
27	I, II, III	3+	1090	1490	63	3243	56	T,C,S,X,IG
26	I, II, III	3+	1152	1490	71	3243	56	T,C,S,X,IG
23	I, II, III	3+	1317	1490	80	3243	56	T,C,S,X,IG
20	I, II, III	2.7	1469	1490	90	3243	56	T,C,S,X,IG
18	I, II, III	2.4	1647	1490	100	3243	56	T,C,S,X,IG
15	I, II, III	2.1	1915	1490	112	3243	56	T,C,S,X,IG
14	I, II	1.9	2102	1490	125	3243	56	T,C,S,X,IG
14	I, II, III	3+	2119	2090	125	3363	56	T,C,S,X,IG
13	I, II, III	3+	2322	2090	140	3363	56	T,C,S,X,IG
12	I, II	1.7	2407	1490	140	3243	56	T,C,S,X,IG
11	I, II	1.5	2644	1490	160	3243	56	T,C,S,X,IG
11	I, II, III	2.6	2712	2090	160	3363	56	T,C,S,X,IG
10	I, II, III	2.5	2832	2090	180	3365	56	T,C,S,X,IG
10	I, II	1.4	2897	1490	180	3245	56	T,C,S,X°,IG
9.4	I	1.3	3171	1490	125	3243	56 †	T,C,X
9.3	I, II, III	2.2	3196	2090	125	3363	56 †	T,C,X
8.9	I, II, III	2.2	3190	2090	200	3365	56	T,C,S,X,IG
8.9	I	1.2	3207	1490	200	3245	56	T,C,S,X°,IG
8.5	I, II, III	2.1	3503	2090	140	3363	56 †	T,C,X
8.5	I	1.2	3369	1490	224	3245	56	T,C,S,X°,IG
8.3	I, II, III	3+	3554	2875	140	3473	56 †	T,C,X
8.2	I	1.1	3631	1490	140	3243	56 †	T,C,X
7.9	I, II, III	2.0	3614	2090	224	3365	56	T,C,S,X,IG
7.5	I, II, III	3+	3938	2875	160	3473	56 †	T,C,X

◇ **Standard Motor Types** (see page B-15 for product codes)

T TEFC, three phase, 208-230/460 or 575 volts

S TEFC, single phase, 115/230 volts

C Corro-Duty, three phase, 230/460 or 575 volts

X° Explosionproof, CL1 group D, three phase, 230/460 or 575 volts

X Explosionproof, Cl 1 group D, Cl 2 groups F&G, three phase, 230/460 or 575 volts

IG IntelliGear variable speed for 1-ph/115V, 1-ph/230V, 3-ph/230V, or 3-ph/460V power supplies, NEMA 4/12

Δ Overhung load rating is at shaft midpoint.

† Denotes 6-pole (1200 rpm) motor.

General Specifications: Totally enclosed, 60 hertz, 40°C ambient, continuous duty.

Output rpm	AGMA Class	Service Factor	Output Torque in-lb	OHL Δ lb	Nominal Ratio	Frame Size Gear	Motor	Std. Motor Types ◇
7.4	I	1.0	3989	1490	160	3243	56 †	T,C,X
7.3	I, II	1.8	4091	2090	160	3363	56 †	T,C,X
7.1	I	1.0	4004	1490	250	3245	56	T,C,S,X°,IG
7.0	I, II, III	3+	4069	2875	250	3475	56	T,C,S,X,IG
6.9	I, II	1.7	4102	2090	250	3365	56	T,C,S,X,IG
6.1	I, II, III	3+	4655	2875	280	3475	56	T,C,S,X,IG
6.1	I, II	1.5	4688	2090	280	3365	56	T,C,S,X,IG
5.4	I, II, III	2.7	5241	2875	315	3475	56	T,C,S,X,IG
5.4	I	1.3	5290	2090	315	3365	56	T,C,S,X,IG
5.1	I, II, III	2.6	5567	2875	355	3475	56	T,C,S,X,IG
5.1	I	1.3	5616	2090	355	3365	56	T,C,S,X,IG
4.5	I, II, III	2.3	6283	2875	400	3475	56	T,C,S,X,IG
4.3	I	1.1	6674	2090	400	3365	56	T,C,S,X,IG
4.2	I, II, III	3+	6723	4100	450	3585	56	T,C,S,X,IG
4.0	I	1.0	7064	2090	450	3365	56	T,C,S,X,IG
4.0	I, II, III	2.0	7113	2875	450	3475	56	T,C,S,X,IG
3.6	I, II	1.8	7846	2875	500	3475	56	T,C,S,X,IG
3.6	I, II, III	2.9	7976	4100	500	3585	56	T,C,S,X,IG
3.4	I, II, III	2.7	8432	4100	560	3585	56	T,C,S,X,IG
3.2	I, II	1.6	8920	2875	560	3475	56	T,C,S,X,IG
3.0	I, II, III	2.4	9636	4100	630	3585	56	T,C,S,X,IG
2.8	I, II	1.4	10190	2875	630	3475	56	T,C,S,X,IG
2.6	I, II, III	2.1	10759	4100	710	3585	56	T,C,S,X,IG
2.5	I	1.2	11508	2875	710	3475	56	T,C,S,X,IG
2.4	I, II	1.9	12061	4100	800	3585	56	T,C,S,X,IG
2.3	I	1.2	12208	2875	800	3475	56	T,C,S,X,IG
2.0	I, II	1.7	14096	4100	900	3585	56	T,C,S,X,IG
2.0	I	1.0	14503	2875	900	3475	56	T,C,S,X,IG
1.9	I, II, III	2.2	14420	6060	900	2606A	56	T,C,S,X,IG
1.8	I, II	1.5	15887	4100	1000	3585	56	T,C,S,X,IG
1.6	I	1.3	17986	4100	1120	3585	56	T,C,S,X,IG
1.5	I, II	1.7	18648	6060	1120	2606A	56	T,C,S,X,IG
1.5	I, II, III	2.6	18648	7556	1120	2706A	56	T,C,S,X,IG
1.4	I	1.1	20428	4100	1250	3585	56	T,C,S,X,IG
1.4	I, II	1.6	20243	6060	1250	2606A	56	T,C,S,X,IG
1.4	I, II, III	2.4	20243	7343	1250	2706A	56	T,C,S,X,IG
1.3	I	1.1	21470	4100	1400	3585	56	T,C,S,X,IG
1.2	I, II	1.4	22572	6060	1400	2606A	56	T,C,S,X,IG
1.2	I, II, III	2.2	22572	7130	1400	2706A	56	T,C,S,X,IG

◇ Standard Motor Types (see page B-15 for product codes)

T TEFC, three phase, 208-230/460 or 575 volts

S TEFC, single phase, 115/230 volts

C Corro-Duty, three phase, 230/460 or 575 volts

X° Explosionproof, CL1 group D, three phase, 230/460 or 575 volts

X Explosionproof, Cl 1 group D, Cl 2 groups F&G, three phase, 230/460 or 575 volts

IG IntelliGear variable speed for 1-ph/115V, 1-ph/230V, 3-ph/230V, or 3-ph/460V power supplies, NEMA 4/12

Δ Overhung load rating is at shaft midpoint.

† Denotes 6-pole (1200 rpm) motor.

General Specifications: Totally enclosed, 60 hertz, 40°C ambient, continuous duty.

Output rpm	AGMA Class	Service Factor	Output Torque in-lb	OHL Δ lb	Nominal Ratio	Frame Size Gear	Motor	Std. Motor Types ◇
1.2	I	1.0	24400	4100	1600	3585	56	T,C,S,X,IG
1.1	I	1.3	25331	5982	1600	2606A	56	T,C,S,X,IG
1.1	I, II	1.9	25331	6801	1600	2706A	56	T,C,S,X,IG
1.1	I, II, III	3+	25874	12100	1600	2806A	56	T,C,S,X,IG
1.0	I, II, III	3+	27772	12100	1800	2806A	56	T,C,S,X,IG
1.0	I	1.1	28665	5794	1800	2606A	56	T,C,S,X,IG
1.0	I, II	1.7	28665	6472	1800	2706A	56	T,C,S,X,IG
0.90	I	1.0	31186	5606	2000	2606A	56	T,C,S,X,IG
0.90	I, II	1.6	31186	6248	2000	2706A	56	T,C,S,X,IG
0.86	I, II, III	2.7	32318	11782	2000	2806A	56	T,C,S,X,IG
0.80	I, II, III	2.5	35062	11255	2240	2806A	56	T,C,S,X,IG
0.79	I, II	1.4	35237	6026	2240	2706A	56	T,C,S,X,IG
0.72	I, II, III	2.3	38731	10727	2500	2806A	56	T,C,S,X,IG
0.69	I	1.2	40581	5804	2500	2706A	56	T,C,S,X,IG
0.65	I, II, III	2.1	43006	10137	2800	2806A	56	T,C,S,X,IG
0.62	I	1.1	45351	5581	2800	2706A	56	T,C,S,X,IG
0.55	I, II	1.7	50982	8785	3150	2806A	56	T,C,S,X,IG

◇ **Standard Motor Types** (see page B-15 for product codes)

T TEFC, three phase, 208-230/460 or 575 volts

S TEFC, single phase, 115/230 volts

C Corro-Duty, three phase, 230/460 or 575 volts

X° Explosionproof, CL1 group D, three phase, 230/460 or 575 volts

X Explosionproof, Cl 1 group D, Cl 2 groups F&G, three phase, 230/460 or 575 volts

IG IntelliGear variable speed for 1-ph/115V, 1-ph/230V, 3-ph/230V, or 3-ph/460V power supplies, NEMA 4/12

Δ Overhung load rating is at shaft midpoint.

General Specifications: Totally enclosed, 60 hertz, 40°C ambient, continuous duty.

Output rpm	AGMA Class	Service Factor	Output Torque in-lb	OHL Δ lb	Nominal Ratio	Frame Size Gear	Motor	Std. Motor Types ◇
179	I, II, III	3+	249	1092	10	3243	56	T,C,S,X,IG
141	I, II, III	3+	315	1173	12.5	3243	56	T,C,S,X,IG
126	I, II, III	3+	353	1213	14	3243	56	T,C,S,X,IG
109	I, II, III	3+	409	1267	16	3243	56	T,C,S,X,IG
105	I, II, III	3+	422	1278	18	3243	56	T,C,S,X,IG
86	I, II, III	3+	519	1357	20	3243	56	T,C,S,X,IG
76	I, II, III	3+	582	1402	22.4	3243	56	T,C,S,X,IG
73	I, II, III	3+	613	1422	25	3243	56	T,C,S,X,IG
64	I, II, III	3+	694	1472	28	3243	56	T,C,S,X,IG
57	I, II, III	3+	783	1490	31.5	3243	56	T,C,S,X,IG
50	I, II, III	3+	885	1490	35.5	3243	56	T,C,S,X,IG
44	I, II, III	3+	1004	1490	40	3243	56	T,C,S,X,IG
39	I, II, III	3+	1149	1490	45	3243	56	T,C,S,X,IG
34	I, II, III	3+	1297	1490	50	3243	56	T,C,S,X,IG
32	I, II, III	2.8	1375	1490	56	3243	56	T,C,S,X,IG
27	I, II, III	2.4	1635	1490	63	3243	56	T,C,S,X,IG
26	I, II, III	2.3	1729	1490	71	3243	56	T,C,S,X,IG
23	I, II, III	2.0	1975	1490	80	3243	56	T,C,S,X,IG
20	I, II, III	3+	2179	2090	90	3363	56	T,C,S,X,IG
20	I, II	1.8	2204	1490	90	3243	56	T,C,S,X,IG
18	I, II, III	2.9	2451	2090	100	3363	56	T,C,S,X,IG
18	I, II	1.6	2471	1490	100	3243	56	T,C,S,X,IG
15	I, II	1.4	2873	1490	112	3243	56	T,C,S,X,IG
15	I, II, III	2.5	2873	2090	112	3363	56	T,C,S,X,IG
14	I	1.3	3152	1490	125	3243	56	T,C,S,X,IG
14	I, II, III	2.2	3178	2090	125	3363	56	T,C,S,X,IG
13	I, II, III	2.1	3483	2090	140	3363	56	T,C,S,X,IG
12	I	1.1	3610	1490	140	3243	56	T,C,S,X,IG
11	I, II, III	3+	3915	2875	160	3473	56	T,C,S,X,IG
11	I	1.0	3966	1490	160	3243	56	T,C,S,X,IG
11	I, II	1.8	4068	2090	160	3363	56	T,C,S,X,IG
10.2	I, II, III	3+	4200	2875	180	3475	56	T,C,S,X,IG
10.1	I, II	1.7	4248	2090	180	3365	56	T,C,S,X,IG
9.4	I, II, III	3+	4756	2875	125	3473	143T †	T,C,X
9.3	I, II	1.5	4794	2090	125	3363	143T †	T,C,X
9.0	I, II, III	3+	4737	2875	200	3475	56	T,C,S,X,IG
8.9	I, II	1.5	4786	2090	200	3365	56	T,C,S,X,IG
8.5	I, II, III	2.1	3503	2090	140	3363	143T †	T,C,X

OtN Series

◇ **Standard Motor Types** (see page B-15 for product codes)

T TEFC, three phase, 208-230/460 or 575 volts

S TEFC, single phase, 115/230 volts

C Corro-Duty, three phase, 230/460 or 575 volts

X Explosionproof, CI 1 group D, CI 2 groups F&G, three phase, 230/460 or 575 volts

IG IntelliGear variable speed for 1-ph/115V, 1-ph/230V, 3-ph/230V, or 3-ph/460V power supplies, NEMA 4/12

Δ Overhung load rating is at shaft midpoint.

† Denotes 6-pole (1200 rpm) motor.

3/4 HP (Continued)

General Specifications: Totally enclosed, 60 hertz, 40°C ambient, continuous duty.

Output rpm	AGMA Class	Service Factor	Output Torque in-lb	OHL Δ lb	Nominal Ratio	Frame Size Gear	Motor	Std. Motor Types ◇
8.3	I, II, III	2.7	5331	2875	140	3473	143T †	T,C,X
8.0	I, II, III	2.6	5372	2875	224	3475	56	T,C,S,X,IG
7.9	I	1.3	5420	2090	224	3365	56	T,C,S,X,IG
7.5	I, II, III	2.4	5906	2875	160	3473	143T †	T,C,X
7.3	I	1.2	6137	2090	160	3363	143T †	T,C,X
7.0	I, II, III	2.3	6104	2875	250	3475	56	T,C,S,X,IG
6.9	I	1.1	6153	2090	250	3365	56	T,C,S,X,IG
6.1	I, II, III	2.0	6983	2875	280	3475	56	T,C,S,X,IG
6.1	I	1.0	7032	2090	280	3365	56	T,C,S,X,IG
5.8	I, II, III	3+	7374	4100	315	3585	56	T,C,S,X,IG
5.4	I, II	1.8	7862	2875	315	3475	56	T,C,S,X,IG
5.1	I, II	1.7	8350	2875	355	3475	56	T,C,S,X,IG
5.1	I, II, III	2.7	8423	4100	355	3585	56	T,C,S,X,IG
4.5	I, II	1.5	9425	2875	400	3475	56	T,C,S,X,IG
4.5	I, II, III	2.4	9498	4100	400	3585	56	T,C,S,X,IG
4.2	I, II, III	2.3	10084	4100	450	3585	56	T,C,S,X,IG
4.0	I	1.3	10670	2875	450	3475	56	T,C,S,X,IG
3.6	I	1.2	11768	2875	500	3475	56	T,C,S,X,IG
3.6	I, II	1.9	11964	4100	500	3585	56	T,C,S,X,IG
3.4	I, II	1.8	12647	4100	560	3585	56	T,C,S,X,IG
3.2	I	1.1	13380	2875	560	3475	56	T,C,S,X,IG
3.0	I, II	1.6	14454	4100	630	3585	56	T,C,S,X,IG
2.8	I, II, III	2.1	15089	6060	630	2605A	56	T,C,S,X,IG
2.6	I, II	1.4	16139	4100	710	3585	56	T,C,S,X,IG
2.5	I, II	1.9	16847	6060	710	2605A	56	T,C,S,X,IG
2.5	I, II, III	2.9	16847	7943	710	2705A	56	T,C,S,X,IG
2.4	I	1.3	18092	4100	800	3585	56	T,C,S,X,IG
2.3	I, II	1.7	18654	6060	800	2605A	56	T,C,S,X,IG
2.3	I, II, III	2.6	18654	7861	800	2705A	56	T,C,S,X,IG
2.0	I	1.1	21144	4100	900	3585	56	T,C,S,X,IG
1.9	I, II	1.5	21631	6060	900	2606A	56	T,C,S,X,IG
1.9	I, II, III	2.3	21631	7788	900	2706A	56	T,C,S,X,IG
1.8	I	1.0	23830	4100	1000	3585	56	T,C,S,X,IG
1.7	I	1.3	24837	6060	1000	2606A	56	T,C,S,X,IG
1.7	I, II, III	2.0	24837	7672	1000	2706A	56	T,C,S,X,IG
1.5	I	1.2	27971	6060	1120	2606A	56	T,C,S,X,IG
1.5	I, II	1.8	27971	7556	1120	2706A	56	T,C,S,X,IG
1.4	I, II, III	2.9	30053	12100	1250	2806A	56	T,C,S,X,IG

◇ **Standard Motor Types** (see page B-15 for product codes)

T TEFC, three phase, 208-230/460 or 575 volts

S TEFC, single phase, 115/230 volts

C Corro-Duty, three phase, 230/460 or 575 volts

X Explosionproof, CI 1 group D, CI 2 groups F&G, three phase, 230/460 or 575 volts

IG IntelliGear variable speed for 1-ph/115V, 1-ph/230V, 3-ph/230V, or 3-ph/460V power supplies, NEMA 4/12

Δ Overhung load rating is at shaft midpoint.

† Denotes 6-pole (1200 rpm) motor.

General Specifications: Totally enclosed, 60 hertz, 40°C ambient, continuous duty.

Output rpm	AGMA Class	Service Factor	Output Torque in-lb	OHL Δ lb	Nominal Ratio	Frame Size Gear	Frame Size Motor	Std. Motor Types ◇
1.4	I	1.1	30364	6060	1250	2606A	56	T,C,S,X,IG
1.4	I, II	1.6	30364	7343	1250	2706A	56	T,C,S,X,IG
1.2	I	1.0	33858	6060	1400	2606A	56	T,C,S,X,IG
1.2	I, II	1.4	33858	7130	1400	2706A	56	T,C,S,X,IG
1.2	I, II, III	2.6	34001	12100	1400	2806A	56	T,C,S,X,IG
1.1	I	1.3	37997	6801	1600	2706A	56	T,C,S,X,IG
1.1	I, II, III	2.3	38811	12100	1600	2806A	56	T,C,S,X,IG
1.0	I, II, III	2.1	41658	12100	1800	2806A	56	T,C,S,X,IG
0.97	I	1.1	42998	6472	1800	2706A	56	T,C,S,X,IG
0.90	I	1.0	46778	6248	2000	2706A	56	T,C,S,X,IG
0.86	I, II	1.8	48477	11782	2000	2806A	56	T,C,S,X,IG
0.80	I, II	1.7	52593	11255	2240	2806A	56	T,C,S,X,IG
0.72	I, II	1.5	58096	10727	2500	2806A	56	T,C,S,X,IG
0.65	I, II	1.4	64509	10137	2800	2806A	56	T,C,S,X,IG
0.55	I	1.2	76473	8785	3150	2806A	56	T,C,S,X,IG

OtN Series

◇ **Standard Motor Types** (see page B-15 for product codes)

T TEFC, three phase, 208-230/460 or 575 volts

S TEFC, single phase, 115/230 volts

C Corro-Duty, three phase, 230/460 or 575 volts

X Explosionproof, Cl 1 group D, Cl 2 groups F&G, three phase, 230/460 or 575 volts

IG IntelliGear variable speed for 1-ph/115V, 1-ph/230V, 3-ph/230V, or 3-ph/460V power supplies, NEMA 4/12

Δ Overhung load rating is at shaft midpoint.

General Specifications: Totally enclosed, 60 hertz, 40°C ambient, continuous duty.

Output rpm	AGMA Class	Service Factor	Output Torque in-lb	OHL Δ lb	Nominal Ratio	Frame Size Gear	Motor	Std. Motor Types ◇
179	I, II, III	3+	332	1076	10	3243	143T	T,C,S,X,IG
141	I, II, III	3+	420	1153	12.5	3243	143T	T,C,S,X,IG
126	I, II, III	3+	471	1191	14	3243	143T	T,C,S,X,IG
109	I, II, III	3+	546	1241	16	3243	143T	T,C,S,X,IG
105	I, II, III	3+	563	1251	18	3243	143T	T,C,S,X,IG
86	I, II, III	3+	691	1324	20	3243	143T	T,C,S,X,IG
76	I, II, III	3+	776	1365	22.4	3243	143T	T,C,S,X,IG
73	I, II, III	3+	817	1383	25	3243	143T	T,C,S,X,IG
64	I, II, III	3+	925	1428	28	3243	143T	T,C,S,X,IG
57	I, II, III	3+	1044	1471	31.5	3243	143T	T,C,S,X,IG
50	I, II, III	3+	1180	1490	35.5	3243	143T	T,C,S,X,IG
44	I, II, III	2.9	1339	1490	40	3243	143T	T,C,S,X,IG
39	I, II, III	2.6	1532	1490	45	3243	143T	T,C,S,X,IG
34	I, II, III	2.3	1729	1490	50	3243	143T	T,C,S,X,IG
32	I, II, III	2.1	1834	1490	56	3243	143T	T,C,S,X,IG
29	I, II, III	3+	2068	2090	63	3363	143T	T,C,S,X,IG
27	I, II	1.8	2180	1490	63	3243	143T	T,C,S,X,IG
26	I, II, III	3+	2298	2090	71	3363	143T	T,C,S,X,IG
26	I, II	1.7	2305	1490	71	3243	143T	T,C,S,X,IG
23	I, II, III	2.7	2610	2090	80	3363	143T	T,C,S,X,IG
23	I, II	1.5	2634	1490	80	3243	143T	T,C,S,X,IG
20	I, II, III	2.4	2905	2090	90	3363	143T	T,C,S,X,IG
20	I	1.3	2939	1490	90	3243	143T	T,C,S,X,IG
18	I, II, III	2.2	3268	2090	100	3363	143T	T,C,S,X,IG
18	I	1.2	3295	1490	100	3243	143T	T,C,S,X,IG
16	I, II, III	3+	3661	2875	112	3473	143T	T,C,S,X,IG
15	I	1.0	3830	1490	112	3243	143T	T,C,S,X,IG
15	I, II	1.9	3830	2090	112	3363	143T	T,C,S,X,IG
14	I, II, III	3+	4203	2875	125	3473	143T	T,C,S,X,IG
14	I, II	1.7	4237	2090	125	3363	143T	T,C,S,X,IG
13	I, II	1.5	4644	2090	140	3363	143T	T,C,S,X,IG
13	I, II, III	3+	4712	2875	140	3473	143T	T,C,S,X,IG
11	I, II, III	2.7	5220	2875	160	3473	143T	T,C,S,X,IG
11	I	1.3	5424	2090	160	3363	143T	T,C,S,X,IG
10.2	I, II, III	2.5	5599	2875	180	3475	143T	T,C,S,X,IG
10.1	I	1.2	5664	2090	180	3365	143T	T,C,S,X,IG
9.0	I, II, III	2.2	6316	2875	200	3475	143T	T,C,S,X,IG
8.9	I	1.1	6381	2090	200	3365	143T	T,C,S,X,IG
8.0	I, II, III	2.0	7162	2875	224	3475	143T	T,C,S,X,IG
7.9	I	1.0	7227	2090	224	3365	143T	T,C,S,X,IG
7.4	I, II, III	3+	7650	4100	250	3585	143T	T,C,S,X,IG
7.0	I, II	1.7	8139	2875	250	3475	143T	T,C,S,X,IG

◇ **Standard Motor Types** (see page B-15 for product codes)

T TEFC, three phase, 208-230/460 or 575 volts

S TEFC, single phase, 115/230 volts

C Corro-Duty, three phase, 230/460 or 575 volts

X Explosionproof, CI 1 group D, CI 2 groups F&G, three phase, 230/460 or 575 volts

IG IntelliGear variable speed for 1-ph/230V, 3-ph/230V, or 3-ph/460V power supplies, NEMA 4/12

Δ Overhung load rating is at shaft midpoint.



Gearmotors

1 HP (Continued)

OtN
SERIES 2000
3000

General Specifications: Totally enclosed, 60 hertz, 40°C ambient, continuous duty.

Output rpm	AGMA Class	Service Factor	Output Torque in-lb	OHL Δ lb	Nominal Ratio	Frame Size Gear	Frame Size Motor	Std. Motor Types ◇
6.6	I, II, III	2.6	8627	4100	280	3585	143T	T,C,S,X,IG
6.1	I, II	1.5	9310	2875	280	3475	143T	T,C,S,X,IG
5.8	I, II, III	2.3	9831	4100	315	3585	143T	T,C,S,X,IG
5.4	I	1.3	10482	2875	315	3475	143T	T,C,S,X,IG
5.1	I	1.3	11133	2875	355	3475	143T	T,C,S,X,IG
5.1	I, II, III	2.0	11231	4100	355	3585	143T	T,C,S,X,IG
4.5	I	1.1	12566	2875	400	3475	143T	T,C,S,X,IG
4.5	I, II	1.8	12664	4100	400	3585	143T	T,C,S,X,IG
4.2	I, II	1.7	13445	4100	450	3585	143T	T,C,S,X,IG
4.0	I, II, III	2.3	14194	6060	450	2605A	143T	T,C,S,X,IG
4.0	I	1.0	14226	2875	450	3475	143T	T,C,S,X,IG
3.7	I, II, III	2.1	15463	6060	500	2605A	143T	T,C,S,X,IG
3.7	I, II, III	3+	15463	7897	500	2705A	143T	T,C,S,X,IG
3.6	I, II	1.4	15951	4100	500	3585	143T	T,C,S,X,IG
3.4	I, II	1.4	16863	4100	560	3585	143T	T,C,S,X,IG
3.0	I	1.2	19272	4100	630	3585	143T	T,C,S,X,IG
2.8	I, II	1.6	20118	6060	630	2605A	143T	T,C,S,X,IG
2.8	I, II, III	2.4	20118	7691	630	2705A	143T	T,C,S,X,IG
2.6	I	1.1	21518	4100	710	3585	143T	T,C,S,X,IG
2.5	I, II	1.4	22462	6060	710	2605A	143T	T,C,S,X,IG
2.5	I, II, III	2.2	22462	7745	710	2705A	143T	T,C,S,X,IG
2.3	I	1.3	24871	6060	800	2605A	143T	T,C,S,X,IG
2.3	I, II, III	2.0	24871	7595	800	2705A	143T	T,C,S,X,IG
2.2	I, II, III	3+	25685	12100	800	2805A	143T	T,C,S,X,IG
2.0	I, II, III	3+	27341	12100	900	2806A	143T	T,C,S,X,IG
1.9	I	1.1	28840	6060	900	2606A	143T	T,C,S,X,IG
1.9	I, II	1.7	28840	7460	900	2706A	143T	T,C,S,X,IG
1.7	I, II, III	2.8	31967	12100	1000	2806A	143T	T,C,S,X,IG
1.7	I	1.0	33115	6060	1000	2606A	143T	T,C,S,X,IG
1.7	I, II	1.5	33115	7242	1000	2706A	143T	T,C,S,X,IG
1.6	I, II, III	2.5	35668	12100	1120	2806A	143T	T,C,S,X,IG
1.5	I	1.3	37295	7023	1120	2706A	143T	T,C,S,X,IG
1.4	I, II, III	2.2	40070	12100	1250	2806A	143T	T,C,S,X,IG
1.4	I	1.2	40485	6602	1250	2706A	143T	T,C,S,X,IG
1.2	I	1.1	45143	6181	1400	2706A	143T	T,C,S,X,IG
1.2	I, II, III	2.0	45334	12100	1400	2806A	143T	T,C,S,X,IG
1.1	I	1.0	50662	5958	1600	2706A	143T	T,C,S,X,IG
1.1	I, II	1.7	51747	12100	1600	2806A	143T	T,C,S,X,IG
1.0	I, II	1.6	55543	12100	1800	2806A	143T	T,C,S,X,IG
0.86	I, II	1.4	64635	11782	2000	2806A	143T	T,C,S,X,IG
0.80	I	1.3	70123	11255	2240	2806A	143T	T,C,S,X,IG
0.72	I	1.1	77460	10727	2500	2806A	143T	T,C,S,X,IG
0.65	I	1.0	86010	10137	2800	2806A	143T	T,C,S,X,IG

◇ Standard Motor Types (see page B-15 for product codes)

T TEFC, three phase, 208-230/460 or 575 volts

S TEFC, single phase, 115/230 volts

C Corro-Duty, three phase, 230/460 or 575 volts

X Explosionproof, Cl 1 group D, Cl 2 groups F&G, three phase, 230/460 or 575 volts

IG IntelliGear variable speed for 1-ph/230V, 3-ph/230V, or 3-ph/460V power supplies, NEMA 4/12

Δ Overhung load rating is at shaft midpoint.

General Specifications: Totally enclosed, 60 hertz, 40°C ambient, continuous duty.

Output rpm	AGMA Class	Service Factor	Output Torque in-lb	OHL Δ lb	Nominal Ratio	Frame Size Gear	Motor	Std. Motor Types ◇
179	I, II, III	3+	498	1045	10	3243	145T	T,C,S,X,IG
141	I, II, III	3+	630	1113	12.5	3243	145T	T,C,S,X,IG
126	I, II, III	3+	707	1146	14	3243	145T	T,C,S,X,IG
109	I, II, III	3+	819	1189	16	3243	145T	T,C,S,X,IG
105	I, II, III	3+	844	1198	18	3243	145T	T,C,S,X,IG
86	I, II, III	3+	1037	1258	20	3243	145T	T,C,S,X,IG
76	I, II, III	3+	1164	1291	22.4	3243	145T	T,C,S,X,IG
73	I, II, III	3+	1225	1306	25	3243	145T	T,C,S,X,IG
64	I, II, III	2.7	1388	1340	28	3243	145T	T,C,S,X,IG
57	I, II, III	2.5	1566	1372	31.5	3243	145T	T,C,S,X,IG
50	I, II, III	2.2	1769	1403	35.5	3243	145T	T,C,S,X,IG
46	I, II, III	3+	1947	2090	40	3363	145T	T,C,S,X,IG
44	I, II	1.9	2008	1433	40	3243	145T	T,C,S,X,IG
40	I, II, III	3+	2222	2090	45	3363	145T	T,C,S,X,IG
39	I, II	1.7	2298	1461	45	3243	145T	T,C,S,X,IG
35	I, II, III	2.7	2557	2090	50	3363	145T	T,C,S,X,IG
34	I, II	1.5	2593	1483	50	3243	145T	T,C,S,X,IG
33	I, II, III	2.6	2735	2090	56	3363	145T	T,C,S,X,IG
32	I, II	1.4	2751	1490	56	3243	145T	T,C,S,X,IG
29	I, II, III	2.3	3102	2090	63	3363	145T	T,C,S,X,IG
27	I	1.2	3269	1490	63	3243	145T	T,C,S,X,IG
26	I, II, III	2.0	3447	2090	71	3363	145T	T,C,S,X,IG
26	I	1.1	3457	1490	71	3243	145T	T,C,S,X,IG
23	I, II	1.8	3915	2090	80	3363	145T	T,C,S,X,IG
23	I, II, III	3+	3940	2875	80	3473	145T	T,C,S,X,IG
23	I	1.0	3951	1490	80	3243	145T	T,C,S,X,IG
20	I, II	1.6	4357	2090	90	3363	145T	T,C,S,X,IG
20	I, II, III	3+	4459	2875	90	3473	145T	T,C,S,X,IG
18	I, II, III	2.9	4851	2875	100	3473	145T	T,C,S,X,IG
18	I, II	1.4	4901	2090	100	3363	145T	T,C,S,X,IG
16	I, II, III	2.6	5491	2875	112	3473	145T	T,C,S,X,IG
15	I	1.2	5745	2090	112	3363	145T	T,C,S,X,IG
14	I, II, III	2.3	6305	2875	125	3473	145T	T,C,S,X,IG
14	I	1.1	6356	2090	125	3363	145T	T,C,S,X,IG
13	I	1.0	6966	2090	140	3363	145T	T,C,S,X,IG
13	I, II, III	2.0	7067	2875	140	3473	145T	T,C,S,X,IG
11	I, II	1.8	7830	2875	160	3473	145T	T,C,S,X,IG
10.2	I, II	1.7	8399	2875	180	3475	145T	T,C,S,X,IG
10	I, II, III	2.7	8497	4100	180	3585	145T	T,C,S,X,IG
9.5	I, II, III	2.5	8985	4100	200	3585	145T	T,C,S,X,IG

◇ **Standard Motor Types** (see page B-15 for product codes)
 T TEFC, three phase, 208-230/460 or 575 volts
 S TEFC, single phase, 115/230 volts (Note that the frame is 145TY for single phase).
 C Corro-Duty, three phase, 230/460 or 575 volts
 X Explosionproof, CI 1 group D, CI 2 groups F&G, three phase, 230/460 or 575 volts
 IG IntelliGear variable speed for 1-ph/230V, 3-ph/230V, or 3-ph/460V power supplies, NEMA 4/12
 Δ Overhung load rating is at shaft midpoint.



Gearmotors

1 1/2 HP (Continued)

OtN
SERIES 2000
3000

General Specifications: Totally enclosed, 60 hertz, 40°C ambient, continuous duty.

Output rpm	AGMA Class	Service Factor	Output Torque in-lb	OHL Δ lb	Nominal Ratio	Frame Size Gear	Frame Size Motor	Std. Motor Types ◇
9.0	I, II	1.5	9473	2875	200	3475	145T	T,C,S,X,IG
8.4	I, II, III	2.2	10157	4100	224	3585	145T	T,C,S,X,IG
8.0	I	1.3	10743	2875	224	3475	145T	T,C,S,X,IG
7.4	I, II, III	2.0	11475	4100	250	3585	145T	T,C,S,X,IG
7.0	I	1.2	12208	2875	250	3475	145T	T,C,S,X,IG
6.6	I, II	1.8	12940	4100	280	3585	145T	T,C,S,X,IG
6.1	I	1.0	13966	2875	280	3475	145T	T,C,S,X,IG
5.8	I, II	1.5	14747	4100	315	3585	145T	T,C,S,X,IG
5.7	I, II, III	2.2	15040	6060	315	2605A	145T	T,C,S,X,IG
5.1	I, II	1.9	16798	6060	355	2605A	145T	T,C,S,X,IG
5.1	I, II, III	2.9	16798	7863	355	2705A	145T	T,C,S,X,IG
5.1	I, II	1.4	16847	4100	355	3585	145T	T,C,S,X,IG
4.5	I, II	1.7	18849	6060	400	2605A	145T	T,C,S,X,IG
4.5	I, II, III	2.6	18849	7770	400	2705A	145T	T,C,S,X,IG
4.5	I	1.2	18995	4100	400	3585	145T	T,C,S,X,IG
4.2	I	1.1	20167	4100	450	3585	145T	T,C,S,X,IG
4.0	I, II	1.5	21290	6060	450	2605A	145T	T,C,S,X,IG
4.0	I, II, III	2.3	21290	7679	450	2705A	145T	T,C,S,X,IG
3.7	I, II	1.4	23195	6060	500	2605A	145T	T,C,S,X,IG
3.7	I, II, III	2.1	23195	7515	500	2705A	145T	T,C,S,X,IG
3.6	I	1.0	23927	4100	500	3585	145T	T,C,S,X,IG
3.3	I	1.2	26222	6060	560	2605A	145T	T,C,S,X,IG
3.3	I, II	1.9	26222	7344	560	2705A	145T	T,C,S,X,IG
3.2	I, II, III	3+	26466	12100	560	2805A	145T	T,C,S,X,IG
2.9	I, II, III	3+	29250	12100	630	2805A	145T	T,C,S,X,IG
2.8	I	1.1	30178	6060	630	2605A	145T	T,C,S,X,IG
2.8	I, II	1.6	30178	7018	630	2705A	145T	T,C,S,X,IG
2.6	I, II, III	2.7	32473	12100	710	2805A	145T	T,C,S,X,IG
2.5	I	1.0	33693	6060	710	2605A	145T	T,C,S,X,IG
2.5	I, II	1.5	33693	7149	710	2705A	145T	T,C,S,X,IG
2.3	I	1.3	37307	6778	800	2705A	145T	T,C,S,X,IG
2.2	I, II, III	2.3	38528	12100	800	2805A	145T	T,C,S,X,IG
2.0	I, II, III	2.2	41011	12100	900	2806A	145T	T,C,S,X,IG
1.9	I	1.1	43260	6431	900	2706A	145T	T,C,S,X,IG
1.7	I, II	1.8	47950	11903	1000	2806A	145T	T,C,S,X,IG
1.7	I	1.0	49673	6208	1000	2706A	145T	T,C,S,X,IG
1.6	I, II	1.7	53501	11534	1120	2806A	145T	T,C,S,X,IG
1.4	I, II	1.5	60105	10829	1250	2806A	145T	T,C,S,X,IG
1.2	I	1.3	68001	10123	1400	2806A	145T	T,C,S,X,IG
1.1	I	1.1	77620	8362	1600	2806A	145T	T,C,S,X,IG
1.0	I	1.1	83315	6601	1800	2806A	145T	T,C,S,X,IG

◇ Standard Motor Types (see page B-15 for product codes)

T TEFC, three phase, 208-230/460 or 575 volts

S TEFC, single phase, 115/230 volts (Note that the frame is 145TY for single phase).

C Corro-Duty, three phase, 230/460 or 575 volts

X Explosionproof, CI 1 group D, CI 2 groups F&G, three phase, 230/460 or 575 volts

IG IntelliGear variable speed for 1-ph/230V, 3-ph/230V, or 3-ph/460V power supplies, NEMA 4/12

Δ Overhung load rating is at shaft midpoint.

General Specifications: Totally enclosed, 60 hertz, 40°C ambient, continuous duty.

Output rpm	AGMA Class	Service Factor	Output Torque in-lb	OHL Δ lb	Nominal Ratio	Frame Size Gear	Motor ‡	Std. Motor Types ◇
179	I, II, III	3+	664	1013	10	3243	145T	T,C,S,X,IG
141	I, II, III	3+	841	1073	12.5	3243	145T	T,C,S,X,IG
126	I, II, III	3+	942	1102	14	3243	145T	T,C,S,X,IG
109	I, II, III	3+	1091	1138	16	3243	145T	T,C,S,X,IG
105	I, II, III	2.7	1125	1145	18	3243	145T	T,C,S,X,IG
86	I, II, III	2.6	1383	1193	20	3243	145T	T,C,S,X,IG
76	I, II, III	2.4	1552	1218	22.4	3243	145T	T,C,S,X,IG
73	I, II, III	2.3	1634	1228	25	3243	145T	T,C,S,X,IG
64	I, II, III	2.0	1851	1252	28	3243	145T	T,C,S,X,IG
57	I, II, III	3+	2074	2090	31.5	3363	145T	T,C,S,X,IG
57	I, II	1.8	2088	1273	31.5	3243	145T	T,C,S,X,IG
51	I, II, III	3+	2346	2090	35.5	3363	145T	T,C,S,X,IG
50	I, II	1.6	2359	1291	35.5	3243	145T	T,C,S,X,IG
46	I, II, III	2.7	2597	2090	40	3363	145T	T,C,S,X,IG
44	I, II	1.5	2678	1306	40	3243	145T	T,C,S,X,IG
40	I, II, III	2.4	2963	2090	45	3363	145T	T,C,S,X,IG
39	I	1.3	3064	1316	45	3243	145T	T,C,S,X,IG
35	I, II, III	2.1	3410	2090	50	3363	145T	T,C,S,X,IG
34	I	1.1	3457	1319	50	3243	145T	T,C,S,X,IG
33	I, II	1.9	3647	2090	56	3363	145T	T,C,S,X,IG
32	I	1.1	3668	1319	56	3243	145T	T,C,S,X,IG
31	I, II, III	3+	3864	2875	56	3473	145T	T,C,S,X,IG
29	I, II	1.7	4135	2090	63	3363	145T	T,C,S,X,IG
28	I, II, III	3+	4196	2875	63	3473	145T	T,C,S,X,IG
26	I, II	1.5	4596	2090	71	3363	145T	T,C,S,X,IG
25	I, II, III	3+	4678	2875	71	3473	145T	T,C,S,X,IG
23	I, II	1.4	5220	2090	80	3363	145T	T,C,S,X,IG
23	I, II, III	2.7	5254	2875	80	3473	145T	T,C,S,X,IG
20	I	1.2	5810	2090	90	3363	145T	T,C,S,X,IG
20	I, II, III	2.4	5946	2875	90	3473	145T	T,C,S,X,IG
18	I, II, III	2.2	6468	2875	100	3473	145T	T,C,S,X,IG
18	I	1.1	6535	2090	100	3363	145T	T,C,S,X,IG
16	I, II	1.9	7322	2875	112	3473	145T	T,C,S,X,IG
14	I, II, III	2.8	8203	4100	125	3583	145T	T,C,S,X,IG
14	I, II	1.7	8406	2875	125	3473	145T	T,C,S,X,IG
13	I, II, III	2.5	9084	4100	140	3583	145T	T,C,S,X,IG
13	I, II	1.5	9423	2875	140	3473	145T	T,C,S,X,IG
11	I, II	1.4	10440	2875	160	3473	145T	T,C,S,X,IG
11	I, II, III	2.1	10779	4100	160	3583	145T	T,C,S,X,IG
10.2	I	1.3	11199	2875	180	3475	145T	T,C,S,X,IG
10	I, II, III	2.0	11329	4100	180	3585	145T	T,C,S,X,IG
9.5	I, II	1.9	11980	4100	200	3585	145T	T,C,S,X,IG

◇ **Standard Motor Types** (see page B-15 for product codes)

T TEFC, three phase, 208-230/460 or 575 volts

S TEFC, single phase, 115/230 volts

C Corro-Duty, three phase, 230/460 or 575 volts

X Explosionproof, CI 1 group D, CI 2 groups F&G, three phase, 230/460 or 575 volts

IG IntelliGear variable speed for 1-ph/230V, 3-ph/230V, or 3-ph/460V power supplies, NEMA 4/12

Δ Overhung load rating is at shaft midpoint.

‡ Single phase, inverter duty and IntelliGear motors are 145TY.

General Specifications: Totally enclosed, 60 hertz, 40°C ambient, continuous duty.

Output rpm	AGMA Class	Service Factor	Output Torque in-lb	OHL Δ lb	Nominal Ratio	Frame Size Gear	Motor ‡	Std. Motor Types ◇
9.0	I	1.1	12631	2875	200	3475	145T	T,C,S,X,IG
8.4	I, II	1.7	13543	4100	224	3585	145T	T,C,S,X,IG
8.0	I	1.0	14324	2875	224	3475	145T	T,C,S,X,IG
7.4	I, II	1.5	15301	4100	250	3585	145T	T,C,S,X,IG
6.9	I, II, III	2.0	16408	6060	250	2605A	145T	T,C,S,X,IG
6.9	I, II, III	3+	16408	7902	250	2705A	145T	T,C,S,X,IG
6.6	I	1.3	17254	4100	280	3585	145T	T,C,S,X,IG
6.2	I, II	1.8	18491	6060	280	2605A	145T	T,C,S,X,IG
6.2	I, II, III	2.6	18491	7829	280	2705A	145T	T,C,S,X,IG
5.8	I	1.2	19663	4100	315	3585	145T	T,C,S,X,IG
5.7	I, II	1.6	20054	6060	315	2605A	145T	T,C,S,X,IG
5.7	I, II, III	2.4	20054	7733	315	2705A	145T	T,C,S,X,IG
5.1	I, II	1.4	22398	6060	355	2605A	145T	T,C,S,X,IG
5.1	I, II, III	2.2	22398	7599	355	2705A	145T	T,C,S,X,IG
5.1	I	1.0	22463	4100	355	3585	145T	T,C,S,X,IG
4.5	I	1.3	25132	6060	400	2605A	145T	T,C,S,X,IG
4.5	I, II	1.9	25132	7426	400	2705A	145T	T,C,S,X,IG
4.4	I, II, III	3+	26044	12100	400	2805A	145T	T,C,S,X,IG
4.0	I	1.1	28388	6060	450	2605A	145T	T,C,S,X,IG
4.0	I, II	1.7	28388	7256	450	2705A	145T	T,C,S,X,IG
3.7	I	1.0	30927	6060	500	2605A	145T	T,C,S,X,IG
3.7	I, II	1.6	30927	6944	500	2705A	145T	T,C,S,X,IG
3.5	I, II, III	2.7	32555	12100	500	2805A	145T	T,C,S,X,IG
3.3	I, II	1.4	34964	6611	560	2705A	145T	T,C,S,X,IG
3.2	I, II, III	2.5	35289	12100	560	2805A	145T	T,C,S,X,IG
2.9	I, II, III	2.3	39000	12100	630	2805A	145T	T,C,S,X,IG
2.8	I	1.2	40237	5949	630	2705A	145T	T,C,S,X,IG
2.6	I, II, III	2.0	43298	12095	710	2805A	145T	T,C,S,X,IG
2.5	I	1.1	44925	6219	710	2705A	145T	T,C,S,X,IG
2.3	I	1.0	49743	5986	800	2705A	145T	T,C,S,X,IG
2.2	I, II	1.7	51371	11774	800	2805A	145T	T,C,S,X,IG
2.0	I, II	1.6	54682	11109	900	2806A	145T	T,C,S,X,IG
1.7	I, II	1.4	63934	10356	1000	2806A	145T	T,C,S,X,IG
1.6	I	1.2	71335	9603	1120	2806A	145T	T,C,S,X,IG
1.4	I	1.1	80140	8980	1250	2806A	145T	T,C,S,X,IG
1.2	I	1.0	90668	8357	1400	2806A	145T	T,C,S,X,IG

OtN Series

◇ **Standard Motor Types** (see page B-15 for product codes)

T TEFC, three phase, 208-230/460 or 575 volts

S TEFC, single phase, 115/230 volts

C Corro-Duty, three phase, 230/460 or 575 volts

X Explosionproof, CI 1 group D, CI 2 groups F&G, three phase, 230/460 or 575 volts

IG IntelliGear variable speed for 1-ph/230V, 3-ph/230V, or 3-ph/460V power supplies, NEMA 4/12

Δ Overhung load rating is at shaft midpoint.

‡ Single phase, inverter duty and IntelliGear motors are 145TY.

General Specifications: Totally enclosed, 60 hertz, 40°C ambient, continuous duty.

Output rpm	AGMA Class	Service Factor	Output Torque in-lb	OHL Δ lb	Nominal Ratio	Frame Size Gear	Motor	Std. Motor Types ◇
179	I, II, III	3+	830	982	10	3243	145TY	T, C
141	I, II, III	2.8	1051	1033	12.5	3243	145TY	T, C
126	I, II, III	2.5	1178	1057	14	3243	145TY	T, C
109	I, II, III	2.4	1364	1086	16	3243	145TY	T, C
105	I, II, III	2.1	1407	1092	18	3243	145TY	T, C
86	I, II, III	2.0	1729	1127	20	3243	145TY	T, C
76	I, II	1.9	1941	1144	22.4	3243	145TY	T, C
75	I, II, III	3+	1974	2090	22.4	3363	145TY	T, C
73	I, II	1.8	2042	1151	25	3243	145TY	T, C
72	I, II, III	3+	2059	2090	25	3363	145TY	T, C
64	I, II	1.6	2313	1165	28	3243	145TY	T, C
61	I, II, III	3+	2432	2090	28	3363	145TY	T, C
57	I, II, III	2.8	2593	2090	31.5	3363	145TY	T, C
57	I, II	1.5	2610	1174	31.5	3243	145TY	T, C
51	I, II, III	2.4	2932	2090	35.5	3363	145TY	T, C
50	I	1.3	2949	1179	35.5	3243	145TY	T, C
46	I, II, III	2.1	3246	2090	40	3363	145TY	T, C
44	I	1.2	3347	1179	40	3243	145TY	T, C
40	I, II	1.9	3703	2090	45	3363	145TY	T, C
40	I, II, III	3+	3737	2875	45	3473	145TY	T, C
39	I	1.0	3830	1171	45	3243	145TY	T, C
35	I, II	1.6	4263	2090	50	3363	145TY	T, C
35	I, II, III	3+	4288	2875	50	3473	145TY	T, C
33	I, II	1.5	4559	2090	56	3363	145TY	T, C
31	I, II, III	2.8	4830	2875	56	3473	145TY	T, C
29	I, II	1.4	5169	2090	63	3363	145TY	T, C
28	I, II, III	2.6	5246	2875	63	3473	145TY	T, C
26	I	1.2	5746	2090	71	3363	145TY	T, C
25	I, II, III	2.4	5847	2875	71	3473	145TY	T, C
23	I	1.1	6525	2090	80	3363	145TY	T, C
23	I, II, III	2.1	6568	2875	80	3473	145TY	T, C
20	I	1.0	7262	2090	90	3363	145TY	T, C
20	I, II	1.9	7432	2875	90	3473	145TY	T, C
18	I, II	1.7	8084	2875	100	3473	145TY	T, C
17	I, II, III	2.7	8559	4100	100	3583	145TY	T, C
16	I, II	1.6	9152	2875	112	3473	145TY	T, C
16	I, II, III	2.5	9237	4100	112	3583	145TY	T, C
14	I, II, III	2.2	10254	4100	125	3583	145TY	T, C
14	I, II	1.4	10508	2875	125	3473	145TY	T, C
13	I, II, III	2.0	11355	4100	140	3583	145TY	T, C

◇ Standard Motor Types (see page B-15 for product codes)

T TEFC, three phase, 208-230/460 or 575 volts

C Corro-Duty, three phase, 230/460 or 575 volts

Δ Overhung load rating is at shaft midpoint.

General Specifications: Totally enclosed, 60 hertz, 40°C ambient, continuous duty.

Output rpm	AGMA Class	Service Factor	Output Torque in-lb	OHL Δ lb	Nominal Ratio	Frame Size Gear	Frame Size Motor	Std. Motor Types ◇
13	I	1.2	11779	2875	140	3473	145TY	T, C
11	I	1.1	13050	2875	160	3473	145TY	T, C
11	I, II, III	2.5	12753	6060	160	2605A	145TY	T, C
11	I, II	1.7	13474	4100	160	3583	145TY	T, C
10.2	I	1.0	13998	2875	180	3475	145TY	T, C
10	I, II, III	2.3	14080	6060	180	2605A	145TY	T, C
10	I, II	1.6	14161	4100	180	3585	145TY	T, C
9.5	I, II	1.5	14975	4100	200	3585	145TY	T, C
8.8	I, II, III	2.0	16196	6060	200	2605A	145TY	T, C
8.8	I, II, III	3+	16196	7895	200	2705A	145TY	T, C
8.4	I	1.3	16928	4100	224	3585	145TY	T, C
8.0	I, II	1.8	17824	6060	224	2605A	145TY	T, C
8.0	I, II, III	2.7	17824	7830	224	2705A	145TY	T, C
7.4	I	1.2	19126	4100	250	3585	145TY	T, C
6.9	I, II, III	2.4	20509	7735	250	2705A	145TY	T, C
6.6	I	1.1	21567	4100	280	3585	145TY	T, C
6.2	I, II	1.4	23114	6060	280	2605A	145TY	T, C
6.2	I, II, III	2.1	23114	7619	280	2705A	145TY	T, C
5.7	I, II, III	2.0	25067	7463	315	2705A	145TY	T, C
5.6	I, II, III	3+	25230	12100	315	2805A	145TY	T, C
5.1	I	1.2	27997	6060	355	2605A	145TY	T, C
5.1	I, II	1.8	27997	7246	355	2705A	145TY	T, C
5.0	I, II, III	3+	28567	12100	355	2805A	145TY	T, C
4.5	I	1.0	31415	5982	400	2605A	145TY	T, C
4.5	I, II	1.6	31415	6960	400	2705A	145TY	T, C
4.4	I, II, III	2.7	32555	12100	400	2805A	145TY	T, C
4.1	I, II, III	2.5	34996	12100	450	2805A	145TY	T, C
4.0	I, II	1.4	35484	6674	450	2705A	145TY	T, C
3.7	I	1.3	38659	6133	500	2705A	145TY	T, C
3.5	I, II, III	2.2	40693	12100	500	2805A	145TY	T, C
3.3	I	1.1	43705	5528	560	2705A	145TY	T, C
3.2	I, II, III	2.0	44111	12022	560	2805A	145TY	T, C
2.9	I, II	1.8	48750	11673	630	2805A	145TY	T, C
2.8	I	1.0	50297	5295	630	2705A	145TY	T, C
2.6	I, II	1.6	54122	11145	710	2805A	145TY	T, C
2.2	I, II	1.4	64214	10595	800	2805A	145TY	T, C
2.0	I	1.3	68353	9406	900	2806A	145TY	T, C
1.7	I	1.1	79918	8773	1000	2806A	145TY	T, C
1.6	I	1.0	89170	8140	1120	2806A	145TY	T, C

OtN Series

◇ Standard Motor Types (see page B-15 for product codes)

T TEFC, three phase, 208-230/460 or 575 volts

C Corro-Duty, three phase, 230/460 or 575 volts

Δ Overhung load rating is at shaft midpoint.

General Specifications: Totally enclosed, 60 hertz, 40°C ambient, continuous duty.

Output rpm	AGMA Class	Service Factor	Output Torque in-lb	OHL Δ lb	Nominal Ratio	Frame Size Gear	Motor	Std. Motor Types ◇
179	I, II, III	2.5	997	951	10	3243	182T	T,C,S,X,IG
141	I, II, III	2.3	1261	993	12.5	3243	182T	T,C,S,X,IG
126	I, II, III	2.1	1414	1012	14	3243	182T	T,C,S,X,IG
109	I, II, III	2.0	1637	1034	16	3243	182T	T,C,S,X,IG
105	I, II	1.8	1688	1038	18	3243	182T	T,C,S,X,IG
94	I, II, III	3+	1891	2090	18	3363	182T	T,C,S,X,IG
86	I, II, III	3+	2064	2090	20	3363	182T	T,C,S,X,IG
86	I, II	1.7	2074	1062	20	3243	182T	T,C,S,X,IG
76	I, II	1.6	2329	1071	22.4	3243	182T	T,C,S,X,IG
75	I, II, III	2.9	2369	2090	22.4	3363	182T	T,C,S,X,IG
73	I, II	1.5	2451	1074	25	3243	182T	T,C,S,X,IG
72	I, II, III	2.8	2471	2090	25	3363	182T	T,C,S,X,IG
64	I, II	1.4	2776	1077	28	3243	182T	T,C,S,X,IG
61	I, II, III	2.5	2919	2090	28	3363	182T	T,C,S,X,IG
57	I, II, III	2.3	3112	2090	31.5	3363	182T	T,C,S,X,IG
57	I	1.2	3132	1075	31.5	3243	182T	T,C,S,X,IG
51	I, II, III	2.0	3518	2090	35.5	3363	182T	T,C,S,X,IG
50	I	1.1	3539	1068	35.5	3243	182T	T,C,S,X,IG
46	I, II	1.8	3895	2090	40	3363	182T	T,C,S,X,IG
44	I	1.0	4017	1052	40	3243	182T	T,C,S,X,IG
44	I, II, III	3+	4057	2875	40	3473	182T	T,C,S,X,IG
40	I, II	1.6	4444	2090	45	3363	182T	T,C,S,X,IG
40	I, II, III	3+	4485	2875	45	3473	182T	T,C,S,X,IG
35	I, II	1.4	5115	2090	50	3363	182T	T,C,S,X,IG
35	I, II, III	2.6	5146	2875	50	3473	182T	T,C,S,X,IG
33	I	1.3	5471	2090	56	3363	182T	T,C,S,X,IG
31	I, II, III	2.4	5796	2875	56	3473	182T	T,C,S,X,IG
29	I	1.1	6203	2090	63	3363	182T	T,C,S,X,IG
28	I, II, III	2.2	6295	2875	63	3473	182T	T,C,S,X,IG
26	I	1.0	6895	2090	71	3363	182T	T,C,S,X,IG
25	I, II, III	2.0	7017	2875	71	3473	182T	T,C,S,X,IG
23	I, II	1.8	7881	2875	80	3473	182T	T,C,S,X,IG
22	I, II, III	2.8	8196	4100	80	3583	182T	T,C,S,X,IG
20	I, II, III	2.6	8796	4100	90	3583	182T	T,C,S,X,IG
20	I, II	1.6	8918	2875	90	3473	182T	T,C,S,X,IG
18	I, II	1.5	9701	2875	100	3473	182T	T,C,S,X,IG
17	I, II, III	2.2	10271	4100	100	3583	182T	T,C,S,X,IG
16	I	1.3	10983	2875	112	3473	182T	T,C,S,X,IG
16	I, II, III	2.1	11084	4100	112	3583	182T	T,C,S,X,IG
14	I, II	1.9	12305	4100	125	3583	182T	T,C,S,X,IG
14	I	1.1	12610	2875	125	3473	182T	T,C,S,X,IG

◇ **Standard Motor Types** (see page B-15 for product codes)

T TEFC, three phase, 208-230/460 or 575 volts

S TEFC, single phase, 230 volts (Note that single phase motor has 184T frame.)

C Corro-Duty, three phase, 230/460 or 575 volts

X Explosionproof, CI 1 group D, CI 2 groups F&G, three phase, 230/460 or 575 volts

IG IntelliGear variable speed for 3-ph/230V or 3-ph/460V power supplies, NEMA 4/12

Δ Overhung load rating is at shaft midpoint.

General Specifications: Totally enclosed, 60 hertz, 40°C ambient, continuous duty.

Output rpm	AGMA Class	Service Factor	Output Torque in-lb	OHL Δ lb	Nominal Ratio	Frame Size Gear	Frame Size Motor	Std. Motor Types ◇
13	I, II	1.7	13627	4100	140	3583	182T	T,C,S,X,IG
13	I	1.0	14135	2875	140	3473	182T	T,C,S,X,IG
12	I, II, III	2.3	13868	6060	140	2605A	182T	T,C,S,X,IG
11	I, II, III	2.1	15333	6060	160	2605A	182T	T,C,S,X,IG
11	I, II	1.4	16169	4100	160	3583	182T	T,C,S,X,IG
10	I, II	1.9	16896	6060	180	2605A	182T	T,C,S,X,IG
10	I, II, III	2.9	16896	7870	180	2705A	182T	T,C,S,X,IG
10	I	1.3	16993	4100	180	3585	182T	T,C,S,X,IG
10	I	1.3	17970	4100	200	3585	182T	T,C,S,X,IG
8.8	I, II	1.5	19435	6060	200	2605A	182T	T,C,S,X,IG
8.8	I, II, III	2.5	19435	7762	200	2705A	182T	T,C,S,X,IG
8.4	I	1.1	20314	4100	224	3585	182T	T,C,S,X,IG
8.0	I, II	1.5	21388	6060	224	2605A	182T	T,C,S,X,IG
8.0	I, II, III	2.3	21388	7666	224	2705A	182T	T,C,S,X,IG
7.4	I	1.0	22951	4100	250	3585	182T	T,C,S,X,IG
6.9	I, II, III	2.0	24611	7526	250	2705A	182T	T,C,S,X,IG
6.3	I, II, III	3+	26955	12100	280	2805A	182T	T,C,S,X,IG
6.2	I	1.2	27737	6060	280	2605A	182T	T,C,S,X,IG
6.2	I, II	1.8	27737	7353	280	2705A	182T	T,C,S,X,IG
5.7	I	1.1	30080	6060	315	2605A	182T	T,C,S,X,IG
5.7	I, II	1.6	30080	7120	315	2705A	182T	T,C,S,X,IG
5.6	I, II, III	2.9	30276	12100	315	2805A	182T	T,C,S,X,IG
5.1	I	1.0	33596	5872	355	2605A	182T	T,C,S,X,IG
5.1	I, II	1.5	33596	6788	355	2705A	182T	T,C,S,X,IG
5.0	I, II, III	2.6	34280	12100	355	2805A	182T	T,C,S,X,IG
4.5	I	1.3	37698	6343	400	2705A	182T	T,C,S,X,IG
4.4	I, II, III	2.3	39065	12100	400	2805A	182T	T,C,S,X,IG
4.1	I, II, III	2.1	41995	12100	450	2805A	182T	T,C,S,X,IG
4.0	I	1.2	42581	5884	450	2705A	182T	T,C,S,X,IG
3.7	I	1.1	46390	4965	500	2705A	182T	T,C,S,X,IG
3.5	I, II	1.8	48832	11922	500	2805A	182T	T,C,S,X,IG
3.2	I, II	1.7	52934	11247	560	2805A	182T	T,C,S,X,IG
2.9	I, II	1.5	58501	10705	630	2805A	182T	T,C,S,X,IG
2.6	I, II	1.4	64946	9862	710	2805A	182T	T,C,S,X,IG
2.2	I	1.2	77057	8945	800	2805A	182T	T,C,S,X,IG
2.0	I	1.1	82024	6767	900	2806A	182T	T,C,S,X,IG

OtN Series

◇ **Standard Motor Types** (see page B-15 for product codes)
 T TEFC, three phase, 208-230/460 or 575 volts
 S TEFC, single phase, 230 volts (Note that single phase motor has 184T frame.)
 C Corro-Duty, three phase, 230/460 or 575 volts
 X Explosionproof, CI 1 group D, CI 2 groups F&G, three phase, 230/460 or 575 volts
 IG IntelliGear variable speed for 3-ph/230V or 3-ph/460V power supplies, NEMA 4/12
 Δ Overhung load rating is at shaft midpoint.

General Specifications: Totally enclosed, 60 hertz, 40°C ambient, continuous duty.

Output rpm	AGMA Class	Service Factor	Output Torque in-lb	OHL Δ lb	Nominal Ratio	Frame Size Gear	Motor	Std. Motor Types ◇
179	I, II, III	3+	1658	1771	10	3363	184T	T,C,S,X,IG
179	I, II	1.5	1661	825	10	3243	184T	T,C,S,X,IG
142	I, II, III	2.7	2085	1866	12.5	3363	184T	T,C,S,X,IG
141	I, II	1.4	2102	834	12.5	3243	184T	T,C,S,X,IG
126	I	1.3	2356	834	14	3243	184T	T,C,S,X,IG
118	I, II, III	2.4	2508	1941	14	3363	184T	T,C,S,X,IG
109	I	1.2	2729	827	16	3243	184T	T,C,S,X,IG
109	I, II, III	2.3	2729	1973	16	3363	184T	T,C,S,X,IG
105	I	1.1	2813	825	18	3243	184T	T,C,S,X,IG
94	I, II, III	2.0	3152	2026	18	3363	184T	T,C,S,X,IG
86	I, II, III	2.0	3441	2057	20	3363	184T	T,C,S,X,IG
86	I	1.0	3457	800	20	3243	184T	T,C,S,X,IG
82	I, II, III	3+	3610	2875	22.4	3473	184T	T,C,S,X,IG
75	I, II	1.7	3949	2090	22.4	3363	184T	T,C,S,X,IG
72	I, II	1.7	4118	2090	25	3363	184T	T,C,S,X,IG
71	I, II, III	3+	4203	2875	25	3473	184T	T,C,S,X,IG
61	I, II, III	2.7	4847	2875	28	3473	184T	T,C,S,X,IG
61	I, II	1.5	4864	2090	28	3363	184T	T,C,S,X,IG
57	I, II	1.4	5186	2090	31.5	3363	184T	T,C,S,X,IG
56	I, II, III	2.5	5339	2875	31.5	3473	184T	T,C,S,X,IG
51	I	1.2	5864	2090	35.5	3363	184T	T,C,S,X,IG
50	I, II, III	2.3	5898	2875	35.5	3473	184T	T,C,S,X,IG
46	I	1.1	6491	2090	40	3363	184T	T,C,S,X,IG
44	I, II, III	2.0	6762	2875	40	3473	184T	T,C,S,X,IG
41	I, II, III	3+	7220	4100	45	3583	184T	T,C,S,X,IG
40	I, II	1.8	7474	2875	45	3473	184T	T,C,S,X,IG
35	I, II, III	2.7	8440	4100	50	3583	184T	T,C,S,X,IG
35	I, II	1.6	8576	2875	50	3473	184T	T,C,S,X,IG
32	I, II, III	2.4	9406	4100	56	3583	184T	T,C,S,X,IG
31	I, II	1.4	9661	2875	56	3473	184T	T,C,S,X,IG
28	I	1.3	10491	2875	63	3473	184T	T,C,S,X,IG
28	I, II, III	2.1	10576	4100	63	3583	184T	T,C,S,X,IG
25	I	1.2	11694	2875	71	3473	184T	T,C,S,X,IG
25	I, II, III	2.5	11864	6060	71	2603	184T	T,C,S,X,IG
25	I, II	1.9	11966	4100	71	3583	184T	T,C,S,X,IG
23	I	1.1	13135	2875	80	3473	184T	T,C,S,X,IG
22	I, II, III	2.2	13406	6060	80	2603	184T	T,C,S,X,IG
22	I, II	1.7	13660	4100	80	3583	184T	T,C,S,X,IG
20	I, II	1.6	14660	4100	90	3583	184T	T,C,S,X,IG
20	I, II, III	2.0	14762	6060	90	2603	184T	T,C,S,X,IG

◇ **Standard Motor Types** (see page B-15 for product codes)

- T TEFC, three phase, 208-230/460 or 575 volts
- S TEFC, single phase, 230 volts
- C Corro-Duty, three phase, 230/460 or 575 volts
- X Explosionproof, CI 1 group D, CI 2 groups F&G, three phase, 230/460 or 575 volts
- IG IntelliGear variable speed for 3-ph/230V or 3-ph/460V power supplies, NEMA 4/12

Δ Overhung load rating is at shaft midpoint.



Gearmotors 5 HP (Continued)

OtN
SERIES 2000
3000

General Specifications: Totally enclosed, 60 hertz, 40°C ambient, continuous duty.

Output rpm	AGMA Class	Service Factor	Output Torque in-lb	OHL Δ lb	Nominal Ratio	Frame Size		Std. Motor Types ◇
						Gear	Motor	
20	I	1.0	14864	2875	90	3473	184T	T,C,S,X,IG
18	I, II	1.8	16864	6060	100	2603	184T	T,C,S,X,IG
18	I, II, III	2.9	16864	7865	100	2703	184T	T,C,S,X,IG
17	I	1.3	17118	4100	100	3583	184T	T,C,S,X,IG
16	I	1.2	18474	4100	112	3583	184T	T,C,S,X,IG
15	I, II	1.5	20225	6060	80	2603	215T †	T,C,X
15	I, II, III	2.4	20225	7865	80	2703	215T †	T,C,X
14	I	1.1	20508	4100	125	3583	184T	T,C,S,X,IG
14	I, II	1.6	20021	6060	125	2605A	184T	T,C,S,X,IG
13	I, II, III	2.2	22270	7610	90	2703	215T †	T,C,X
13	I	1.0	22711	4100	140	3583	184T	T,C,S,X,IG
12	I, II	1.4	23114	6060	140	2605A	184T	T,C,S,X,IG
12	I, II, III	2.1	23114	7412	140	2705A	184T	T,C,S,X,IG
12	I, II, III	3+	24741	12100	160	2805A	184T	T,C,S,X,IG
11	I	1.3	25555	6060	160	2605A	184T	T,C,S,X,IG
11	I, II	1.9	25555	7421	160	2705A	184T	T,C,S,X,IG
10	I, II, III	3+	27509	12100	180	2805A	184T	T,C,S,X,IG
10	I	1.2	28160	6060	180	2605A	184T	T,C,S,X,IG
10	I, II	1.7	28160	7265	180	2705A	184T	T,C,S,X,IG
9.1	I, II, III	2.8	31252	12100	200	2805A	184T	T,C,S,X,IG
8.8	I	1.0	32392	6060	200	2605A	184T	T,C,S,X,IG
8.8	I, II	1.5	32392	6936	200	2705A	184T	T,C,S,X,IG
8.3	I, II, III	2.6	34508	12100	224	2805A	184T	T,C,S,X,IG
8.0	I, II	1.4	35647	6633	224	2705A	184T	T,C,S,X,IG
7.1	I, II, III	2.2	40205	12100	250	2805A	184T	T,C,S,X,IG
6.9	I	1.2	41019	6169	250	2705A	184T	T,C,S,X,IG
6.3	I, II, III	2.0	44925	12100	280	2805A	184T	T,C,S,X,IG
6.2	I	1.1	46228	5563	280	2705A	184T	T,C,S,X,IG
5.7	I	1.0	50134	5330	315	2705A	184T	T,C,S,X,IG
5.6	I, II	1.8	50460	11731	315	2805A	184T	T,C,S,X,IG
5.0	I, II	1.6	57133	11235	355	2805A	184T	T,C,S,X,IG
4.4	I, II	1.4	65109	10435	400	2805A	184T	T,C,S,X,IG
4.1	I	1.3	69992	9173	450	2805A	184T	T,C,S,X,IG
3.5	I	1.1	81386	8064	500	2805A	184T	T,C,S,X,IG
3.2	I	1.0	88223	7431	560	2805A	184T	T,C,S,X,IG

◇ **Standard Motor Types** (see page B-15 for product codes)

T TEFC, three phase, 208-230/460 or 575 volts

S TEFC, single phase, 230 volts

C Corro-Duty, three phase, 230/460 or 575 volts

X Explosionproof, CI 1 group D, CI 2 groups F&G, three phase, 230/460 or 575 volts

IG IntelliGear variable speed for 3-ph/230V or 3-ph/460V power supplies, NEMA 4/12

Δ Overhung load rating is at shaft midpoint.

† Denotes 6-pole (1200 rpm) motor.

OtN Series

General Specifications: Totally enclosed, 60 hertz, 40°C ambient, continuous duty.

Output rpm	AGMA Class	Service Factor	Output Torque in-lb	OHL Δ lb	Nominal Ratio	Frame Size Gear	Motor	Std. Motor Types ◇
179	I, II, III	2.1	2486	1644	10	3363	213T	T,C,X,IG
142	I, II	1.8	3127	1707	12.5	3363	213T	T,C,X,IG
142	I, II, III	3+	3127	2875	12.5	3473	213T	T,C,X,IG
118	I, II	1.6	3763	1750	14	3363	213T	T,C,X,IG
115	I, II, III	3+	3864	2875	14	3473	213T	T,C,X,IG
113	I, II, III	3+	3941	2875	16	3473	213T	T,C,X,IG
109	I, II	1.6	4093	1765	16	3363	213T	T,C,X,IG
100	I, II, III	2.6	4449	2875	18	3473	213T	T,C,X,IG
94	I	1.3	4729	1786	18	3363	213T	T,C,X,IG
87	I, II, III	2.4	5110	2875	20	3473	213T	T,C,X,IG
86	I	1.3	5161	1794	20	3363	213T	T,C,X,IG
82	I, II, III	2.1	5415	2875	22.4	3473	213T	T,C,X,IG
75	I	1.1	5923	1800	22.4	3363	213T	T,C,X,IG
72	I	1.1	6178	1799	25	3363	213T	T,C,X,IG
71	I, II, III	2.0	6305	2875	25	3473	213T	T,C,X,IG
65	I, II, III	3+	6890	4100	28	3583	213T	T,C,X,IG
61	I, II	1.8	7271	2875	28	3473	213T	T,C,X,IG
61	I	1.0	7296	1785	28	3363	213T	T,C,X,IG
57	I, II, III	2.8	7754	4100	31.5	3583	213T	T,C,X,IG
56	I, II	1.7	8008	2875	31.5	3473	213T	T,C,X,IG
51	I, II, III	2.6	8644	4100	35.5	3583	213T	T,C,X,IG
50	I, II	1.5	8847	2875	35.5	3473	213T	T,C,X,IG
45	I, II, III	2.3	9813	4100	40	3583	213T	T,C,X,IG
44	I	1.3	10144	2875	40	3473	213T	T,C,X,IG
41	I, II, III	2.1	10830	4100	45	3583	213T	T,C,X,IG
40	I	1.2	11211	2875	45	3473	213T	T,C,X,IG
35	I, II	1.8	12660	4100	50	3583	213T	T,C,X,IG
35	I	1.0	12864	2875	50	3473	213T	T,C,X,IG
34	I, II, III	2.3	13067	6060	50	2603	213T	T,C,X,IG
32	I, II	1.6	14110	4100	56	3583	213T	T,C,X,IG
30	I, II, III	2.1	14618	6060	56	2603	213T	T,C,X,IG
28	I, II	1.4	15864	4100	63	3583	213T	T,C,X,IG

◇ **Standard Motor Types** (see page B-15 for product codes)

T TEFC, three phase, 208-230/460 or 575 volts

C Corro-Duty, three phase, 230/460 or 575 volts

X Explosionproof, CI 1 group D, CI 2 groups F&G, three phase, 230/460 or 575 volts

IG IntelliGear variable speed for 3-ph/460V power supplies, NEMA 4/12

Δ Overhung load rating is at shaft midpoint.

General Specifications: Totally enclosed, 60 hertz, 40°C ambient, continuous duty.

Output rpm	AGMA Class	Service Factor	Output Torque in-lb	OHL Δ lb	Nominal Ratio	Frame Gear	Size Motor	Std. Motor Types ◇
27	I, II, III	3+	16499	7880	63	2703	213T	T,C,X,IG
25	I, II	1.7	17796	6060	71	2603	213T	T,C,X,IG
25	I, II, III	2.8	17796	7828	71	2703	213T	T,C,X,IG
25	I	1.3	17948	4100	71	3583	213T	T,C,X,IG
22	I, II	1.5	20109	6060	80	2603	213T	T,C,X,IG
22	I, II, III	2.4	20109	7724	80	2703	213T	T,C,X,IG
22	I	1.1	20491	4100	80	3583	213T	T,C,X,IG
20	I	1.0	21991	4100	90	3583	213T	T,C,X,IG
20	I, II	1.4	22143	6060	90	2603	213T	T,C,X,IG
20	I, II, III	2.2	22143	7001	90	2703	213T	T,C,X,IG
18	I	1.2	25296	6060	100	2603	213T	T,C,X,IG
18	I, II	1.9	25296	7440	100	2703	213T	T,C,X,IG
17	I, II, III	3+	25957	12100	100	2803	213T	T,C,X,IG
14	I, II, III	3+	29543	12100	125	2805A	213T	T,C,X,IG
14	I	1.1	30032	6060	125	2605A	213T	T,C,X,IG
12	I, II	1.4	34671	6815	140	2705A	213T	T,C,X,IG
12	I, II, III	2.4	37112	12100	160	2805A	213T	T,C,X,IG
11	I	1.3	38333	6330	160	2705A	213T	T,C,X,IG
10	I, II, III	2.1	41263	12100	180	2805A	213T	T,C,X,IG
10	I	1.2	42240	5907	180	2705A	213T	T,C,X,IG
9	I, II	1.9	46879	11964	200	2805A	213T	T,C,X,IG
9	I	1.0	48588	5674	200	2705A	213T	T,C,X,IG
8	I, II	1.7	51762	11374	224	2805A	213T	T,C,X,IG
7	I, II	1.5	60307	10821	250	2805A	213T	T,C,X,IG
6	I	1.3	67388	10059	280	2805A	213T	T,C,X,IG
6	I	1.2	75689	8819	315	2805A	213T	T,C,X,IG
5	I	1.0	85700	7220	355	2805A	213T	T,C,X,IG

OtN Series

◇ **Standard Motor Types** (see page B-15 for product codes)
 T TEFC, three phase, 208-230/460 or 575 volts
 C Corro-Duty, three phase, 230/460 or 575 volts
 X Explosionproof, CI 1 group D, CI 2 groups F&G, three phase, 230/460 or 575 volts
 IG IntelliGear variable speed for 3-ph/460V power supplies, NEMA 4/12
 Δ Overhung load rating is at shaft midpoint.

General Specifications: Totally enclosed, 60 hertz, 40°C ambient, continuous duty.

Output rpm	AGMA Class	Service Factor	Output Torque in-lb	OHL Δ lb	Nominal Ratio	Frame Size Gear	Frame Size Motor	Std. Motor Types ◇
184	I, II, III	2.5	3224	2761	10	3473	215T	T,C,X,IG
179	I, II	1.6	3315	1518	10	3363	215T	T,C,X,IG
142	I	1.3	4169	1549	12.5	3363	215T	T,C,X,IG
142	I, II, III	2.3	4169	2875	12.5	3473	215T	T,C,X,IG
118	I	1.2	5017	1558	14	3363	215T	T,C,X,IG
115	I, II, III	2.2	5152	2875	14	3473	215T	T,C,X,IG
113	I, II, III	2.2	5254	2875	16	3473	215T	T,C,X,IG
109	I	1.2	5457	1557	16	3363	215T	T,C,X,IG
100	I, II, III	2.0	5932	2875	18	3473	215T	T,C,X,IG
94	I	1.0	6305	1546	18	3363	215T	T,C,X,IG
88	I, II, III	2.9	6779	4100	20	3583	215T	T,C,X,IG
87	I, II	1.8	6813	2875	20	3473	215T	T,C,X,IG
86	I	1.0	6881	1532	20	3363	215T	T,C,X,IG
82	I, II	1.6	7220	2875	22.4	3473	215T	T,C,X,IG
74	I, II, III	2.6	8000	4100	22.4	3583	215T	T,C,X,IG
72	I, II, III	2.6	8237	4100	25	3583	215T	T,C,X,IG
71	I, II	1.5	8406	2875	25	3473	215T	T,C,X,IG
65	I, II, III	2.3	9186	4100	28	3583	215T	T,C,X,IG
61	I	1.3	9694	2875	28	3473	215T	T,C,X,IG
57	I, II, III	2.1	10338	4100	31.5	3583	215T	T,C,X,IG
56	I	1.3	10677	2875	31.5	3473	215T	T,C,X,IG
51	I, II	1.9	11525	4100	35.5	3583	215T	T,C,X,IG
50	I	1.1	11796	2875	35.5	3473	215T	T,C,X,IG
48	I, II, III	2.4	12270	6060	35.5	2603	215T	T,C,X,IG
45	I, II	1.7	13084	4100	40	3583	215T	T,C,X,IG
44	I, II, III	2.2	13491	6060	40	2603	215T	T,C,X,IG
44	I	1.0	13525	2875	40	3473	215T	T,C,X,IG
41	I, II	1.6	14440	4100	45	3583	215T	T,C,X,IG
40	I, II, III	2.0	14881	6060	45	2603	215T	T,C,X,IG
35	I	1.3	16880	4100	50	3583	215T	T,C,X,IG
34	I, II	1.7	17423	6060	50	2603	215T	T,C,X,IG
34	I, II, III	2.8	17423	7843	50	2703	215T	T,C,X,IG
32	I	1.2	18812	4100	56	3583	215T	T,C,X,IG
30	I, II	1.5	19490	6060	56	2603	215T	T,C,X,IG
30	I, II, III	2.5	19490	7753	56	2703	215T	T,C,X,IG
28	I	1.1	21151	4100	63	3583	215T	T,C,X,IG

◇ **Standard Motor Types** (see page B-15 for product codes)

T TEFC, three phase, 208-230/460 or 575 volts

C Corro-Duty, three phase, 230/460 or 575 volts

X Explosionproof, CI 1 group D, CI 2 groups F&G, three phase, 230/460 or 575 volts

IG IntelliGear variable speed for 3-ph/460V power supplies, NEMA 4/12

Δ Overhung load rating is at shaft midpoint.

General Specifications: Totally enclosed, 60 hertz, 40°C ambient, continuous duty.

Output rpm	AGMA Class	Service Factor	Output Torque in-lb	OHL Δ lb	Nominal Ratio	Frame Size Gear	Frame Size Motor	Std. Motor Types ◇
27	I, II	1.4	21999	6060	63	2603	215T	T,C,X,IG
27	I, II, III	2.2	21999	7629	63	2703	215T	T,C,X,IG
25	I	1.3	23727	6060	71	2603	215T	T,C,X,IG
25	I, II, III	2.1	23727	7534	71	2703	215T	T,C,X,IG
25	I	1.0	23931	4100	71	3583	215T	T,C,X,IG
22	I	1.1	26812	6060	80	2603	215T	T,C,X,IG
22	I, II	1.8	26812	7341	80	2703	215T	T,C,X,IG
22	I, II, III	3+	27456	12100	80	2803	215T	T,C,X,IG
20	I	1.0	29524	6023	90	2603	215T	T,C,X,IG
20	I, II	1.7	29524	7148	90	2703	215T	T,C,X,IG
20	I, II, III	3+	29625	12100	90	2803	215T	T,C,X,IG
18	I, II	1.5	33727	6799	100	2703	215T	T,C,X,IG
17	I, II, III	2.5	34608	12100	100	2803	215T	T,C,X,IG
16	I, II, III	2.5	35809	11431	112	2805A	215T	T,C,X,IG
14	I, II, III	2.3	39390	12100	125	2805A	215T	T,C,X,IG
13	I, II, III	2.0	43948	12100	140	2805A	215T	T,C,X,IG
12	I	1.1	46227	5513	140	2705A	215T	T,C,X,IG
11	I	1.0	51110	5280	160	2705A	215T	T,C,X,IG
10	I, II	1.6	55016	11066	180	2805A	215T	T,C,X,IG
9.1	I, II	1.4	62504	10496	200	2805A	215T	T,C,X,IG
8.3	I	1.3	69015	9258	224	2805A	215T	T,C,X,IG
7.1	I	1.1	80409	7994	250	2805A	215T	T,C,X,IG
6.3	I	1.0	89849	7361	280	2805A	215T	T,C,X,IG

OtN Series

◇ **Standard Motor Types** (see page B-15 for product codes)
 T TEFC, three phase, 208-230/460 or 575 volts
 C Corro-Duty, three phase, 230/460 or 575 volts
 X Explosionproof, CI 1 group D, CI 2 groups F&G, three phase, 230/460 or 575 volts
 IG IntelliGear variable speed for 3-ph/460V power supplies, NEMA 4/12
 Δ Overhung load rating is at shaft midpoint.

General Specifications: Totally enclosed, 60 hertz, 40°C ambient, continuous duty.

Output rpm	AGMA Class	Service Factor	Output Torque in-lb	OHL Δ lb	Nominal Ratio	Frame Size Gear	Motor	Std. Motor Types ◇
185	I, II, III	3+	4815	3659	10	3583	254T	T, C, X
184	I, II	1.7	4835	2545	10	3473	254T	T, C, X
142	I, II	1.5	6254	2641	12.5	3473	254T	T, C, X
142	I, II, III	3+	6254	3874	12.5	3583	254T	T, C, X
117	I, II, III	2.6	7576	4022	14	3583	254T	T, C, X
115	I, II	1.5	7728	2698	14	3473	254T	T, C, X
113	I, II	1.5	7881	2702	16	3473	254T	T, C, X
113	I, II, III	2.3	7881	4051	16	3583	254T	T, C, X
100	I	1.3	8898	2720	18	3473	254T	T, C, X
94	I, II, III	2.2	9508	4100	18	3583	254T	T, C, X
88	I, II, III	2.0	10169	4100	20	3583	254T	T, C, X
87	I	1.2	10220	2728	20	3473	254T	T, C, X
82	I	1.1	10830	2726	22.4	3473	254T	T, C, X
78	I, II, III	2.6	11440	6060	22.4	2603	254T	T, C, X
74	I, II	1.8	11999	4100	22.4	3583	254T	T, C, X
72	I, II	1.7	12355	4100	25	3583	254T	T, C, X
71	I	1.0	12609	2705	25	3473	254T	T, C, X
69	I, II, III	2.3	12965	6060	25	2603	254T	T, C, X
65	I, II	1.6	13779	4100	28	3583	254T	T, C, X
63	I, II, III	2.1	14084	6060	28	2603	254T	T, C, X
57	I, II	1.4	15508	4100	31.5	3583	254T	T, C, X
55	I, II	1.9	16067	6060	31.5	2603	254T	T, C, X
51	I	1.3	17287	4100	35.5	3583	254T	T, C, X
48	I, II	1.6	18406	6060	35.5	2603	254T	T, C, X
48	I, II, III	2.6	18406	7802	35.5	2703	254T	T, C, X
45	I	1.1	19626	4100	40	3583	254T	T, C, X
44	I, II	1.5	20236	6060	40	2603	254T	T, C, X
44	I, II, III	2.4	20236	7718	40	2703	254T	T, C, X
41	I	1.0	21660	4100	45	3583	254T	T, C, X
40	I	1.3	22321	6060	45	2603	254T	T, C, X
40	I, II, III	2.2	22321	7612	45	2703	254T	T, C, X
34	I, II, III	3+	25829	12100	50	2803	254T	T, C, X
34	I	1.1	26134	6060	50	2603	254T	T, C, X
34	I, II	1.8	26134	7386	50	2703	254T	T, C, X

◇ **Standard Motor Types** (see page B-15 for product codes)

T TEFC, three phase, 208-230/460 or 575 volts

C Corro-Duty, three phase, 230/460 or 575 volts

X Explosionproof, CI 1 group D, CI 2 groups F&G, three phase, 230/460 or 575 volts

Δ Overhung load rating is at shaft midpoint.

General Specifications: Totally enclosed, 60 hertz, 40°C ambient, continuous duty.

Output rpm	AGMA Class	Service Factor	Output Torque in-lb	OHL Δ lb	Nominal Ratio	Frame Gear	Size Motor	Std. Motor Types ◇
30	I	1.0	29236	6060	56	2603	254T	T, C, X
30	I, II	1.6	29236	7170	56	2703	254T	T, C, X
27	I, II, III	2.6	32947	12100	63	2803	254T	T, C, X
27	I, II	1.5	32998	6864	63	2703	254T	T, C, X
25	I, II	1.4	35591	6622	71	2703	254T	T, C, X
25	I, II, III	2.4	35693	12100	71	2803	254T	T, C, X
22	I	1.2	40218	6117	80	2703	254T	T, C, X
22	I, II, III	2.1	41184	12100	80	2803	254T	T, C, X
20	I	1.1	44286	5578	90	2703	254T	T, C, X
20	I, II, III	2.0	44438	12100	90	2803	254T	T, C, X
17	I, II	1.7	51912	11787	100	2803	254T	T, C, X
16	I, II	1.7	53714	11431	112	2805A	254T	T, C, X
14	I, II	1.5	59086	10522	125	2805A	254T	T, C, X
13	I	1.3	65922	9916	140	2805A	254T	T, C, X
12	I	1.2	74223	8708	160	2805A	254T	T, C, X
10	I	1.1	82525	8075	180	2805A	254T	T, C, X

OtN Series

◇ **Standard Motor Types** (see page B-15 for product codes)

T TEFC, three phase, 208-230/460 or 575 volts

C Corro-Duty, three phase, 230/460 or 575 volts

X Explosionproof, CI 1 group D, CI 2 groups F&G, three phase, 230/460 or 575 volts

Δ Overhung load rating is at shaft midpoint.

General Specifications: Totally enclosed, 60 hertz, 40°C ambient, continuous duty.

OtN Series

Output rpm	AGMA Class	Service Factor	Output Torque in-lb	OHL Δ lb	Nominal Ratio	Frame Size Gear	Motor	Std. Motor Types ◊
185	I, II, III	2.7	6420	3469	10	3583	256T	T, C, X
184	I	1.3	6447	2329	10	3473	256T	T, C, X
142	I	1.2	8339	2361	12.5	3473	256T	T, C, X
142	I, II, III	2.3	8339	3626	12.5	3583	256T	T, C, X
117	I, II	1.9	10101	3722	14	3583	256T	T, C, X
115	I	1.1	10304	2352	14	3473	256T	T, C, X
113	I	1.1	10508	2349	16	3473	256T	T, C, X
113	I, II	1.8	10508	3739	16	3583	256T	T, C, X
111	I, II, III	2.7	10643	6060	16	2603	256T	T, C, X
100	I	1.0	11864	2323	18	3473	256T	T, C, X
94	I, II	1.6	12677	3803	18	3583	256T	T, C, X
88	I, II, III	2.2	13491	6060	20	2603	256T	T, C, X
88	I, II	1.5	13559	3819	20	3583	256T	T, C, X
78	I, II, III	2.0	15253	6060	22.4	2603	256T	T, C, X
74	I	1.3	15999	3837	22.4	3583	256T	T, C, X
72	I	1.3	16474	3837	25	3583	256T	T, C, X
69	I, II	1.7	17287	6060	25	2603	256T	T, C, X
69	I, II, III	2.8	17287	7849	25	2703	256T	T, C, X
65	I	1.2	18372	3826	28	3583	256T	T, C, X
63	I, II	1.6	18779	6060	28	2603	256T	T, C, X
63	I, II, III	2.6	18779	7786	28	2703	256T	T, C, X
57	I	1.1	20677	3793	31.5	3583	256T	T, C, X
55	I, II	1.4	21422	6060	31.5	2603	256T	T, C, X
55	I, II, III	2.2	21422	7659	31.5	2703	256T	T, C, X
51	I	1.0	23050	3742	35.5	3583	256T	T, C, X
48	I	1.2	24541	6060	35.5	2603	256T	T, C, X
48	I, II, III	2.0	24541	7486	35.5	2703	256T	T, C, X
44	I, II, III	3+	26710	12100	40	2803	256T	T, C, X
44	I	1.1	26982	6060	40	2603	256T	T, C, X
44	I, II	1.8	26982	7330	40	2703	256T	T, C, X
40	I, II, III	2.9	29625	12100	45	2803	256T	T, C, X
40	I	1.0	29761	6060	45	2603	256T	T, C, X
40	I, II	1.6	29761	7130	45	2703	256T	T, C, X
34	I, II, III	2.5	34439	12100	50	2803	256T	T, C, X
34	I, II	1.4	34845	6694	50	2703	256T	T, C, X
30	I	1.2	38981	6262	56	2703	256T	T, C, X
27	I, II, III	2.0	43930	12100	63	2803	256T	T, C, X
27	I	1.1	43997	5620	63	2703	256T	T, C, X
25	I	1.0	47455	5078	71	2703	256T	T, C, X
25	I, II	1.8	47590	12098	71	2803	256T	T, C, X
22	I, II	1.6	54912	11550	80	2803	256T	T, C, X
20	I, II	1.5	59251	11173	90	2803	256T	T, C, X
17	I	1.3	69149	10135	100	2803	256T	T, C, X
16	I	1.2	71619	9382	112	2805A	256T	T, C, X
14	I	1.1	78781	7249	125	2805A	256T	T, C, X
13	I	1.0	87896	6616	140	2805A	256T	T, C, X

◊ Standard Motor Types (see page B-15 for product codes)

T TEFC, three phase, 208-230/460 or 575 volts

C Corro-Duty, three phase, 230/460 or 575 volts

X Explosionproof, Cl 1 group D, Cl 2 groups F&G, three phase, 230/460 or 575 volts

Δ Overhung load rating is at shaft midpoint.

General Specifications: Totally enclosed, 60 hertz, 40°C ambient, continuous duty.

Output rpm	AGMA Class	Service Factor	Output Torque in-lb	OHL Δ lb	Nominal Ratio	Frame Size Gear	Frame Size Motor	Std. Motor Types ◇
185	I, II, III	2.2	8025	3278	10	3583	284T	T, C, X
142	I, II	1.8	10423	3379	12.5	3583	284T	T, C, X
141	I, II, III	2.2	10508	6060	12.5	2603	284T	T, C, X
117	I, II	1.5	12626	3422	14	3583	284T	T, C, X
113	I, II	1.4	13135	3427	16	3583	284T	T, C, X
111	I, II, III	2.1	13304	6060	16	2603	284T	T, C, X
94	I	1.3	15847	3427	18	3583	284T	T, C, X
88	I, II	1.8	16863	6060	20	2603	284T	T, C, X
88	I, II, III	2.8	16863	7865	20	2703	284T	T, C, X
88	I	1.2	16948	3416	20	3583	284T	T, C, X
78	I, II	1.6	19067	6060	22.4	2603	284T	T, C, X
78	I, II, III	2.5	19067	7773	22.4	2703	284T	T, C, X
74	I	1.1	19999	3362	22.4	3583	284T	T, C, X
72	I	1.0	20592	3347	25	3583	284T	T, C, X
69	I, II	1.4	21609	6060	25	2603	284T	T, C, X
69	I, II, III	2.2	21609	7650	25	2703	284T	T, C, X
63	I	1.3	23473	6060	28	2603	284T	T, C, X
63	I, II, III	2.0	23473	7548	28	2703	284T	T, C, X
55	I	1.1	26778	6060	31.5	2603	284T	T, C, X
55	I, II	1.8	26778	7344	31.5	2703	284T	T, C, X
54	I, II, III	3+	27541	12100	31.5	2803	284T	T, C, X
49	I, II, III	2.9	30252	12100	35.5	2803	284T	T, C, X
48	I	1.0	30676	6060	35.5	2603	284T	T, C, X
48	I, II	1.6	30676	7059	35.5	2703	284T	T, C, X
44	I, II, III	2.6	33388	12100	40	2803	284T	T, C, X
44	I, II	1.4	33727	6799	40	2703	284T	T, C, X
40	I, II, III	2.3	37032	12100	45	2803	284T	T, C, X
40	I	1.3	37201	6458	45	2703	284T	T, C, X
34	I, II, III	2.0	43048	12100	50	2803	284T	T, C, X
34	I	1.1	43557	5682	50	2703	284T	T, C, X
30	I	1.0	48726	5449	56	2703	284T	T, C, X
30	I, II	1.8	49065	11996	56	2803	284T	T, C, X
27	I, II	1.6	54912	11550	63	2803	284T	T, C, X
25	I, II	1.5	59488	11152	71	2803	284T	T, C, X
22	I	1.3	68640	10203	80	2803	284T	T, C, X
20	I	1.2	74064	9525	90	2803	284T	T, C, X
16	I	1.0	89524	8259	112	2805A	284T	T, C, X

OtN Series

◇ **Standard Motor Types** (see page B-15 for product codes)

T TEFC, three phase, 208-230/460 or 575 volts

C Corro-Duty, three phase, 230/460 or 575 volts

X Explosionproof, CI 1 group D, CI 2 groups F&G, three phase, 230/460 or 575 volts

Δ Overhung load rating is at shaft midpoint.

General Specifications: Totally enclosed, 60 hertz, 40°C ambient, continuous duty.

Output rpm	AGMA Class	Service Factor	Output Torque in-lb	OHL Δ lb	Nominal Ratio	Frame Size Gear	Motor	Std. Motor Types ◇
185	I, II	1.8	9630	3088	10	3583	286T	T, C, X
142	I, II	1.5	12508	3131	12.5	3583	286T	T, C, X
141	I, II	1.8	12609	6060	12.5	2603	286T	T, C, X
117	I	1.3	15152	3122	14	3583	286T	T, C, X
113	I	1.2	15762	3115	16	3583	286T	T, C, X
111	I, II	1.8	15965	6060	16	2603	286T	T, C, X
111	I, II, III	2.5	15965	7900	16	2703	286T	T, C, X
94	I	1.1	19016	3050	18	3583	286T	T, C, X
88	I, II	1.5	20236	6060	20	2603	286T	T, C, X
88	I, II, III	2.3	20236	7718	20	2703	286T	T, C, X
88	I	1.0	20338	3013	20	3583	286T	T, C, X
78	I	1.3	22880	6060	22.4	2603	286T	T, C, X
78	I, II, III	2.1	22880	7582	22.4	2703	286T	T, C, X
69	I	1.2	25931	6060	25	2603	286T	T, C, X
69	I, II	1.9	25931	7399	25	2703	286T	T, C, X
69	I, II, III	3+	25931	12100	25	2803	286T	T, C, X
63	I	1.1	28168	6060	28	2603	286T	T, C, X
63	I, II	1.7	28168	7248	28	2703	286T	T, C, X
62	I, II, III	3+	28778	12100	28	2803	286T	T, C, X
55	I, II	1.5	32134	6939	31.5	2703	286T	T, C, X
54	I, II, III	2.6	33049	12100	31.5	2803	286T	T, C, X
49	I, II, III	2.4	36303	12100	35.5	2803	286T	T, C, X
48	I	1.3	36811	6499	35.5	2703	286T	T, C, X
44	I, II, III	2.2	40065	12100	40	2803	286T	T, C, X
44	I	1.2	40472	6086	40	2703	286T	T, C, X
40	I, II, III	2.0	44438	12100	45	2803	286T	T, C, X
40	I	1.1	44642	5526	45	2703	286T	T, C, X
34	I, II	1.7	51658	11807	50	2803	286T	T, C, X
30	I, II	1.5	58878	11207	56	2803	286T	T, C, X
27	I	1.3	65895	10511	63	2803	286T	T, C, X
25	I	1.2	71386	9872	71	2803	286T	T, C, X
22	I	1.1	82368	8263	80	2803	286T	T, C, X
20	I	1.0	88876	7630	90	2803	286T	T, C, X

◇ **Standard Motor Types** (see page B-15 for product codes)

T TEFC, three phase, 208-230/460 or 575 volts

C Corro-Duty, three phase, 230/460 or 575 volts

X Explosionproof, CI 1 group D, CI 2 groups F&G, three phase, 230/460 or 575 volts

Δ Overhung load rating is at shaft midpoint.

General Specifications: Totally enclosed, 60 hertz, 40°C ambient, continuous duty.

Output rpm	AGMA Class	Service Factor	Output Torque in-lb	OHL Δ lb	Nominal Ratio	Frame Size Gear	Frame Size Motor	Std. Motor Types ◇
141	I, II	1.8	16813	7867	12.5	2703	324T	T, C, X
138	I, II, III	2.6	17219	12100	12.5	2803	324T	T, C, X
111	I, II	1.9	21287	7666	16	2703	324T	T, C, X
111	I, II, III	2.6	21287	12100	16	2803	324T	T, C, X
88	I, II	1.7	26982	7330	20	2703	324T	T, C, X
87	I, II, III	2.6	27253	12100	20	2803	324T	T, C, X
78	I, II	1.6	30507	7072	22.4	2703	324T	T, C, X
77	I, II, III	2.6	30913	12100	22.4	2803	324T	T, C, X
69	I, II	1.4	34574	6720	25	2703	324T	T, C, X
69	I, II, III	2.5	34574	12100	25	2803	324T	T, C, X
63	I	1.3	37557	6420	28	2703	324T	T, C, X
62	I, II, III	2.2	38371	12100	28	2803	324T	T, C, X
55	I	1.1	42845	5781	31.5	2703	324T	T, C, X
54	I, II, III	2.0	44065	12100	31.5	2803	324T	T, C, X
49	I, II	1.8	48404	12042	35.5	2803	324T	T, C, X
48	I	1.0	49082	5548	35.5	2703	324T	T, C, X
44	I, II	1.6	53421	11670	40	2803	324T	T, C, X
40	I, II	1.5	59251	11173	45	2803	324T	T, C, X
34	I	1.3	68877	10175	50	2803	324T	T, C, X
30	I	1.1	78504	8889	56	2803	324T	T, C, X
27	I	1.0	87859	8256	63	2803	324T	T, C, X

OtN Series

◇ **Standard Motor Types** (see page B-15 for product codes)

T TEFC, three phase, 230/460 or 575 volts

C Corro-Duty, three phase, 230/460 or 575 volts

X Explosionproof, CI 1 group D, CI 2 groups F&G, three phase, 230/460 or 575 volts

Δ Overhung load rating is at shaft midpoint.

General Specifications: Totally enclosed, 60 hertz, 40°C ambient, continuous duty.

Output rpm	AGMA Class	Service Factor	Output Torque in-lb	OHL Δ lb	Nominal Ratio	Frame Size Gear	Motor	Std. Motor Types ◇
141	I, II	1.5	21016	7580	12.5	2703	326T	T, C, X
138	I, II, III	2.1	21524	12100	12.5	2803	326T	T, C, X
111	I, II	1.5	26609	7355	16	2703	326T	T, C, X
111	I, II, III	2.1	26609	12100	16	2803	326T	T, C, X
88	I, II	1.4	33727	6799	20	2703	326T	T, C, X
87	I, II, III	2.1	34066	12683	20	2803	326T	T, C, X
78	I	1.3	38133	6357	22.4	2703	326T	T, C, X
77	I, II, III	2.1	38642	12100	22.4	2803	326T	T, C, X
69	I	1.1	43218	5730	25	2703	326T	T, C, X
69	I, II, III	2.0	43218	12100	25	2803	326T	T, C, X
63	I	1.0	46946	5164	28	2703	326T	T, C, X
62	I, II	1.8	47963	12073	28	2803	326T	T, C, X
54	I, II	1.6	55082	11536	31.5	2803	326T	T, C, X
49	I, II	1.4	60505	11057	35.5	2803	326T	T, C, X
44	I	1.3	66776	10414	40	2803	326T	T, C, X
40	I	1.2	74064	9525	45	2803	326T	T, C, X
34	I	1.0	86097	8892	50	2803	326T	T, C, X

◇ **Standard Motor Types** (see page B-15 for product codes)

T TEFC, three phase, 230/460 or 575 volts

C Corro-Duty, three phase, 230/460 or 575 volts

X Explosionproof, CI 1 group D, CI 2 groups F&G, three phase, 230/460 or 575 volts

Δ Overhung load rating is at shaft midpoint.

General Specifications: Totally enclosed, 60 hertz, 40°C ambient, continuous duty.

Output rpm	AGMA Class	Service Factor	Output Torque in-lb	OHL Δ lb	Nominal Ratio	Frame Gear	Size Motor	Std. Motor Types ◇
141	I	1.2	25219	7049	12.5	2703	364T	T, C
138	I, II	1.7	25829	12100	12.5	2803	364T	T, C
111	I	1.3	31930	6824	16	2703	364T	T, C
111	I, II	1.7	31930	12100	16	2803	364T	T, C
88	I	1.2	40472	6268	20	2703	364T	T, C
87	I, II	1.7	40879	12100	20	2803	364T	T, C
78	I	1.0	45760	5826	22.4	2703	364T	T, C
77	I, II	1.7	46370	12100	22.4	2803	364T	T, C
69	I, II	1.7	51861	11936	25	2803	364T	T, C
62	I, II	1.5	57556	11197	28	2803	364T	T, C
54	I	1.3	66098	10660	31.5	2803	364T	T, C
49	I	1.2	72606	10181	35.5	2803	364T	T, C
44	I	1.1	80131	9538	40	2803	364T	T, C
40	I	1.0	88876	8649	45	2803	364T	T, C

◇ **Standard Motor Types** (see page B-15 for product codes)

T TEFC, three phase, 230/460 or 575 volts

C Corro-Duty, three phase, 230/460 or 575 volts

Δ Overhung load rating is at shaft midpoint.

General Specifications: Totally enclosed, 60 hertz, 40°C ambient, continuous duty.

Output rpm	AGMA Class	Service Factor	Output Torque in-lb	OHL Δ lb	Nominal Ratio	Frame Size Gear	Frame Size Motor	Std. Motor Types ◇
141	I	1.0	31524	6518	12.5	2703	365T	T, C
138	I, II	1.4	32286	12100	12.5	2803	365T	T, C
111	I	1.0	39913	6293	16	2703	365T	T, C
111	I, II	1.4	39913	12100	16	2803	365T	T, C
87	I, II	1.4	51099	12100	20	2803	365T	T, C
77	I, II	1.4	57963	12100	22.4	2803	365T	T, C
69	I	1.3	64827	11224	25	2803	365T	T, C
62	I	1.2	71945	10321	28	2803	365T	T, C
54	I	1.1	82622	9784	31.5	2803	365T	T, C
49	I	1.0	90757	9305	35.5	2803	365T	T, C

◇ **Standard Motor Types** (see page B-15 for product codes)

T TEFC, three phase, 230/460 or 575 volts

C Corro-Duty, three phase, 230/460 or 575 volts

Δ Overhung load rating is at shaft midpoint.

Experience the Power of EPT Edge Online

EPT Edge Online is our online
technical support center.

Also available "24-7-365," these electronic tools provide for efficient drive design and product selection:

- **eCatalog (an industry first)** - an interactive, robust electronic "database" with over 100,000 part numbers searchable by part number or general description providing features and benefits of each product line
- **Product Selection (an industry first)** - selection tools with extensive engineering efficiency benefits
- **Smart Interchange** - a dynamic tool that provides the user an intelligent interchange for competitive parts
- **Media Library** - digital (PDF) version of paper catalogs, documents, and downloadable installation and maintenance instructions
- **CAD** - an online service that allows users to view and upload a 2D or 3D CAD template drawing in a number of customer-compatible formats to be integrated into your drawings



OTN Series

www.emerson-ept.com

Connect Here To Be Part of Something Bigger



3-Stage Output Shafted Foot Mount OtN32 - 33

Standard conduit box location will be opposite shaft extension unless specified otherwise.

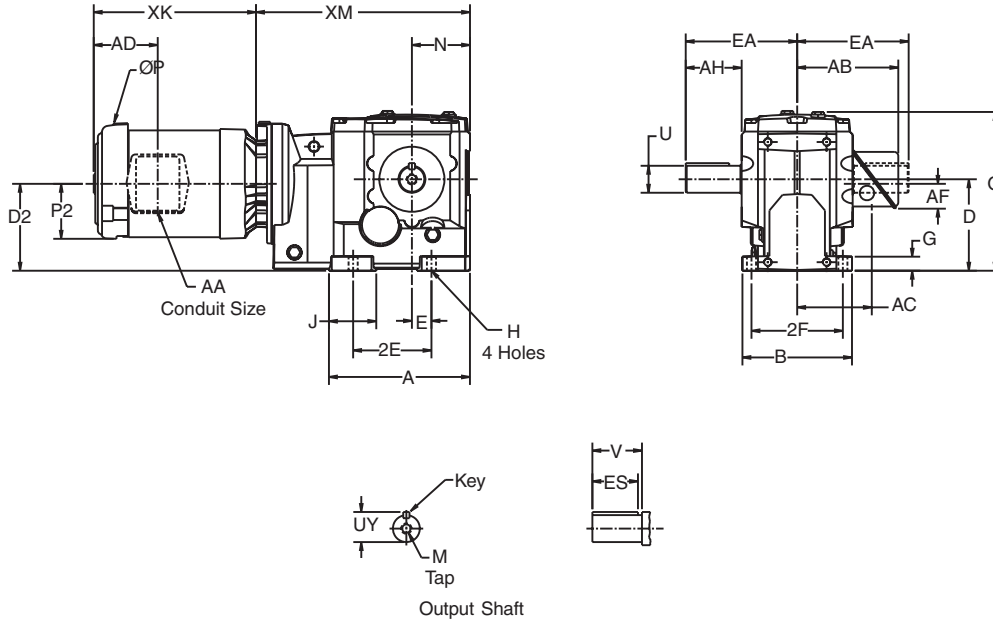

Gear Frame	Version	A	B	D ¹	D2	E	2E	2F	G	H	J	O	N	XM
32	S2	7.81	5.71	4.41	3.78	1.38	5.12	4.72	.73	.43	2.34	8.09	3.03	10.98
33	S2	8.50	6.61	5.51	5.24	1.18	4.72	5.51	.85	.55	2.86	9.69	3.54	12.90
	S1	8.08	8.58	4.92	5.20	3.35	6.69	6.10	.79	.55	2.27	10.43	3.54	12.90

Output Shaft

Gear Frame	Version	U ³	UY	V	AH	EA	Key	ES	M
32	S2	1.250	1.354	2.36	2.46	5.31	1/4 Sq.	2.06	1/2-13 x 1.12
33	S2	1.625	1.783	3.25	3.39	6.73	3/8 Sq.	2.78	5/8-11 x 1.38
	S1	1.500	1.657	3.18	3.19	7.12	3/8 Sq.	2.78	5/8-11 x 1.38

Motor Frame	Motor Type ⁴	Gear Frame	P	P2	AA	AB	AC	AD	AF	XK
56	T	Any	7.31	3.31	.75	6.10	4.50	3.86	1.77	9.79
143T/145T	T	Any	7.31	3.31	.75	6.10	4.50	3.86	1.77	11.04
145TY	T	Any	7.31	3.31	.75	6.10	4.50	3.86	1.77	12.04
182T/184T	T	Any	9.56	4.34	.75	6.10	4.50	5.13	1.77	14.04
213T	T	33	11.25	5.06	1.00	8.42	7.17	5.60	2.42	16.15
215T	T	33	11.25	5.06	1.00	8.42	7.17	5.60	2.42	17.65

¹ Dimension "D" will never be exceeded, but may vary from values shown. When exact dimensions are required, shims up to .03" may be necessary.

² All rough casting dimensions may vary by .25" due to casting variations.

³ Shaft extension tolerances: +.0000"; -.0005" for shafts up to 1.5" diameter "U". Larger diameter: "U", +.000"; -.001".

⁴ Motor dimensions for other than "TypeT" three phase TEFC motors, refer to pages B-98 - B-99.

3-Stage Output Shafted Foot Mount OtN34 - 35

Standard conduit box location will be opposite shaft extension unless specified otherwise.

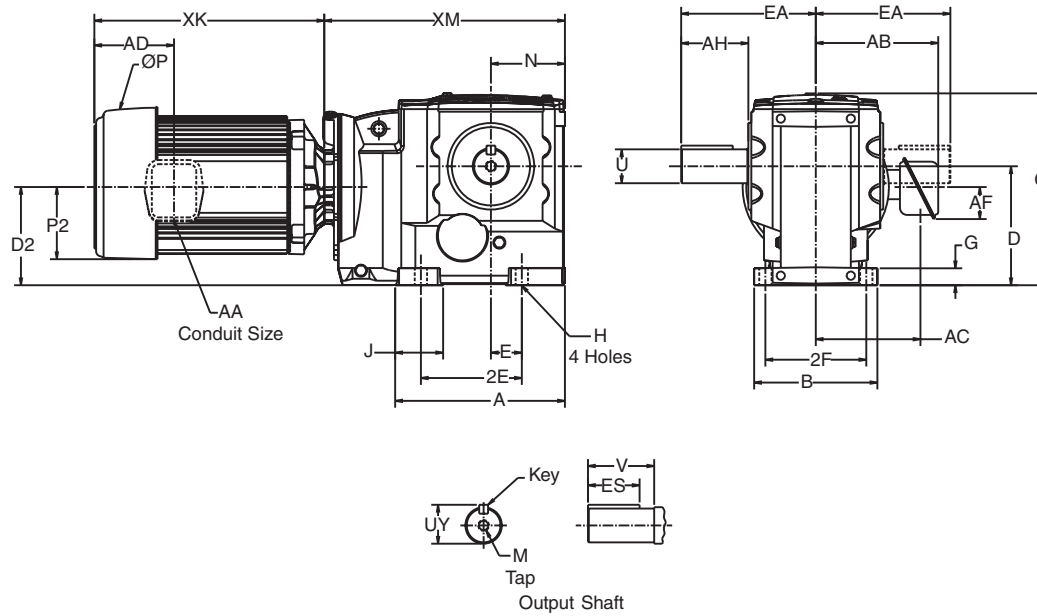

OtN Series

Gear Frame	Version	A	B	D ¹	D ₂	E	2E	2F	G	H	J	O	N	XM	
														56T-215T	254T-286T
34	S2	10.13	7.87	7.09	5.90	1.57	5.91	6.50	1.07	.71	2.67	12.05	4.49	14.56	-
	S1	10.69	9.60	6.30	7.49	4.53	9.06	7.68	1.18	.71	3.19	13.39	4.49		
35	S2	11.92	8.66	8.35	6.89	2.17	7.09	7.09	1.18	.87	3.37	13.58	5.20	16.90	17.25
	S1	13.07	10.98	7.87	9.33	5.51	11.02	9.06	1.40	.87	4.05	16.22	5.20		

Output Shaft

Gear Frame	Version	U ³	UY	V	AH	EA	Key	ES	M
34	S2	2.000	2.21	3.63	3.76	8.11	1/2 Sq.	3.06	3/4-10 X 1.61
	S1	1.750	1.909	3.56	3.66	8.46	3/8 Sq.	3.56	3/4-10 X 1.61
35	S2	2.375	2.638	4.61	4.74	9.45	5/8 Sq.	3.81	3/4-10 X 1.61
	S1	2.375	2.638	5.73	5.27	10.57	5/8 Sq.	4.81	3/4-10 X 1.61

Motor Frame	Motor Type ⁴	Gear Frame	P	P ₂	AA	AB	AC	AD	AF	XK
56	T	Any	7.31	3.31	.75	6.10	4.50	3.86	1.77	9.79
143T/145T	T	Any	7.31	3.31	.75	6.10	4.50	3.86	1.77	11.04
145TY	T	Any	7.31	3.31	.75	6.10	4.50	3.86	1.77	12.04
182T/184T	T	Any	9.56	4.34	.75	6.10	4.50	5.13	1.77	14.04
213T	T	Any	11.25	5.06	1.00	8.42	7.17	5.60	2.42	16.15
215T	T	Any	11.25	5.06	1.00	8.42	7.17	5.60	2.42	17.65
254T	T	34	13.38	6.00	1.25	9.79	7.68	8.29	1.81	20.58
	T	35	13.38	6.00	1.25	9.79	7.68	8.29	1.81	19.61
256T	T	34	13.38	6.00	1.25	9.79	7.68	8.29	1.81	22.33
	T	35	13.38	6.00	1.25	9.79	7.68	8.29	1.81	21.36
284T	T	35	13.38	6.00	1.50	10.58	8.18	8.29	2.13	21.86
286T	T	35	13.38	6.00	1.50	10.33	7.93	8.29	2.13	23.36

¹ Dimension "D" will never be exceeded, but may vary from values shown. When exact dimensions are required, shims up to .03" may be necessary.

² All rough casting dimensions may vary by .25" due to casting variations.

³ Shaft extension tolerances: +.0000"; -.0005" for shafts up to 1.5" diameter "U". Larger diameter: "U", +.000"; -.001".

⁴ Motor dimensions for other than "TypeT" three phase TEFC motors, refer to pages B-98 - B-99.

3-Stage Output Shafted Foot Mount OtN26 - 28

Standard conduit box location will be opposite shaft extension unless specified otherwise.

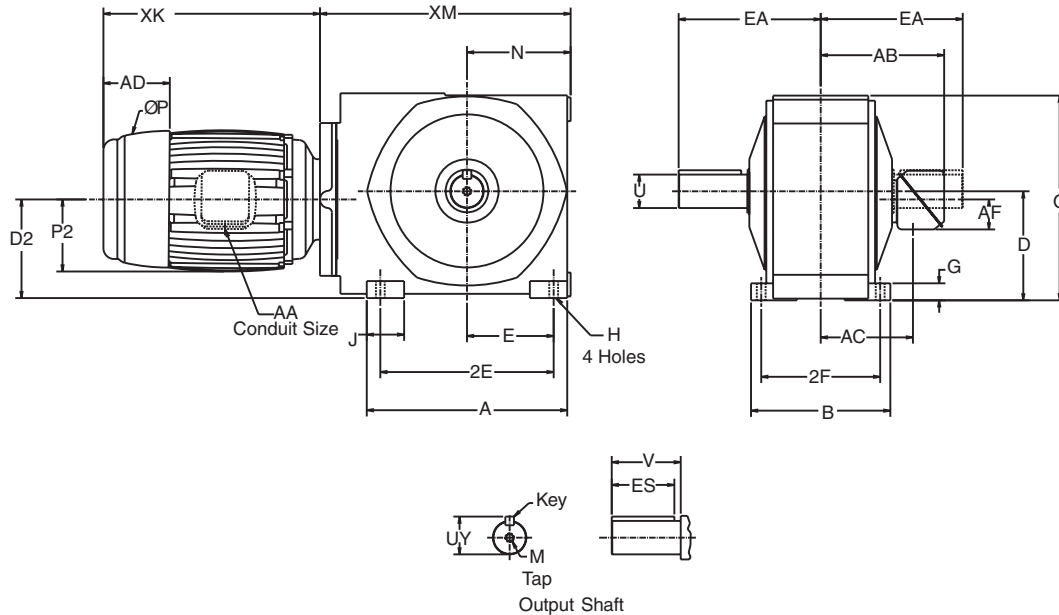

Gear Frame	Version	A	B	D ¹	D2	E	2E	2F	G	H	J	O	N	XM		
														182T-184T	213T-215T	254T-UP
26	S1	16.73	11.42	8.86	8.43	6.99	13.98	9.45	1.57	.87	3.54	16.65	8.74	23.22	24.22	22.21
27	S1	19.29	12.60	9.84	8.66	8.27	16.54	10.63	1.77	.94	3.94	18.50	10.04	25.30	26.30	24.30
28	S1	23.23	16.14	12.40	11.42	10.04	20.08	13.78	1.97	1.02	4.33	23.70	12.01	-	33.04	28.95

Output Shaft

Gear Frame	Version	U ³	UY	V	EA	Key	ES	M
26	S1	2.875	3.200	5.75	12.82	3/4 Sq.	5.13	3/4-10 X 1.97
27	S1	3.500	3.882	7.01	13.70	7/8 Sq.	6.25	1-8 X 1.97
28	S1	3.875	4.426	7.99	17.06	1.00 Sq.	7.25	1-8 X 1.97

Motor Frame	Motor Type ⁴	Gear Frame	P	P2	AA	AB	AC	AD	AF	XK
182T/184T	T	26,27	9.56	4.34	.75	6.10	4.50	5.13	1.77	12.03
213T	T	All	11.25	5.06	1.00	8.42	7.17	5.60	2.42	13.75
215T	T	All	11.25	5.06	1.00	8.42	7.17	5.60	2.42	15.25
254T	T	All	13.38	6.00	1.25	9.79	7.68	8.29	1.81	19.61
256T	T	All	13.38	6.00	1.25	9.79	7.68	8.29	1.81	21.36
284T	T	All	13.38	6.00	1.50	10.58	8.18	8.29	2.13	21.86
286T	T	All	13.38	6.00	1.50	10.33	7.93	8.29	2.13	23.36
324T/326T	T	27,28	17.20	7.78	2.00	14.99	11.34	14.16	3.63	24.96
364T/365T	T	27,28	18.22	9.11	3.00	16.31	12.19	14.37	3.38	26.13

¹ Dimension "D" will never be exceeded, but may vary from values shown. When exact dimensions are required, shims up to .03" may be necessary.

² All rough casting dimensions may vary by .25" due to casting variations.

³ Shaft extension tolerances: +.0000"; -.0005" for shafts up to 1.5" diameter "U". Larger diameter: "U", +.000"; -.001".

⁴ Motor dimensions for other than "TypeT" three phase TEFC motors, refer to pages B-98 - B-99.

Combined Output Shafted Foot Mount OtN32 - 33

Standard conduit box location will be opposite shaft extension unless specified otherwise.

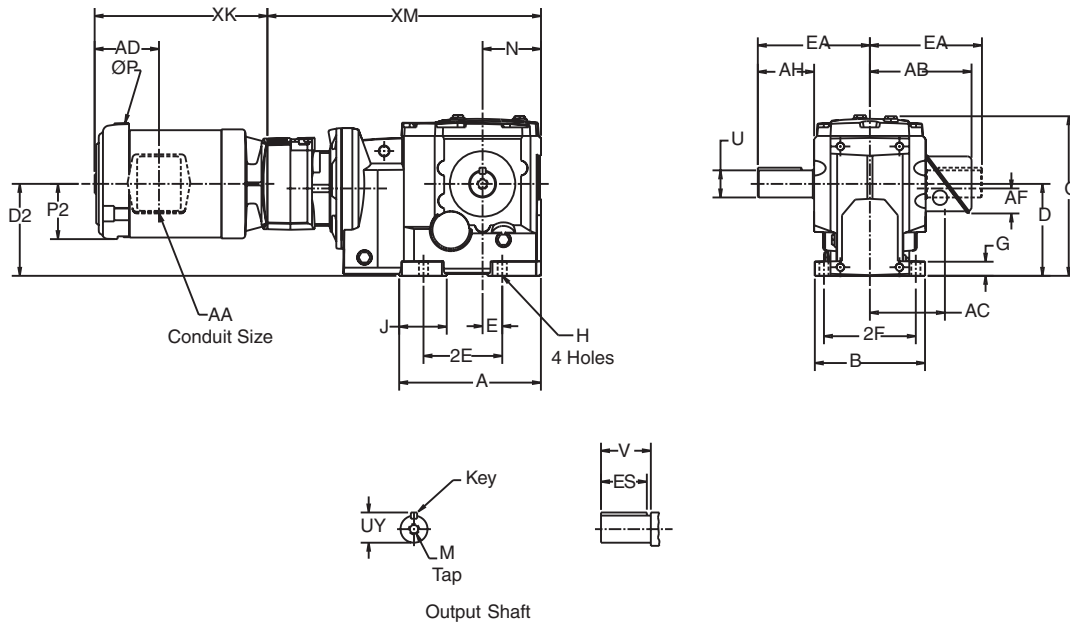

OtN Series

Gear Frame	Version	A	B	D ¹	D2	E	2E	2F	G	H	J	O	N	XM
32	S2	7.81	5.71	4.41	4.06	1.38	5.12	4.72	.73	.43	2.34	8.09	3.03	14.49
33	S2	8.50	6.61	5.51	4.91	1.18	4.72	5.51	.85	.55	2.86	9.69	3.54	19.90
	S1	8.08	8.58	4.92	4.87	3.35	6.69	6.10	.79	.55	2.27	10.43	3.54	19.90

Output Shaft

Gear Frame	Version	U ³	UY	V	AH	EA	Key	ES	M
32	S2	1.250	1.354	2.36	2.46	5.31	1/4 Sq.	2.06	1/2-13 X 1.12
33	S2	1.625	1.783	3.25	3.39	6.73	3/8 Sq.	2.78	5/8-11 X 1.38
	S1	1.500	1.657	3.18	3.19	7.12	3/8 Sq.	2.78	5/8-11 X 1.38

Motor Frame	Motor Type ⁴	Gear Frame	P	P2	AA	AB	AC	AD	AF	XK
56	T	32	7.31	3.31	.75	6.10	4.50	3.86	1.77	10.37
	T	33	7.31	3.31	.75	6.10	4.50	3.86	1.77	9.79
143T/145T	T	32	7.31	3.31	.75	6.10	4.50	3.86	1.77	11.62
	T	33	7.31	3.31	.75	6.10	4.50	3.86	1.77	11.04
145TY	T	33	7.31	3.31	.75	6.10	4.50	3.86	1.77	12.04

¹ Dimension "D" will never be exceeded, but may vary from values shown. When exact dimensions are required, shims up to .03" may be necessary.

² All rough casting dimensions may vary by .25" due to casting variations.

³ Shaft extension tolerances: +.0000"; -.0005" for shafts up to 1.5" diameter "U". Larger diameter: "U", +.000"; -.001".

⁴ Motor dimensions for other than "TypeT" three phase TEFC motors, refer to pages B-98 - B-99.

Combined Output Shafted Foot Mount OtN34 - 35

Standard conduit box location will be opposite shaft extension unless specified otherwise.

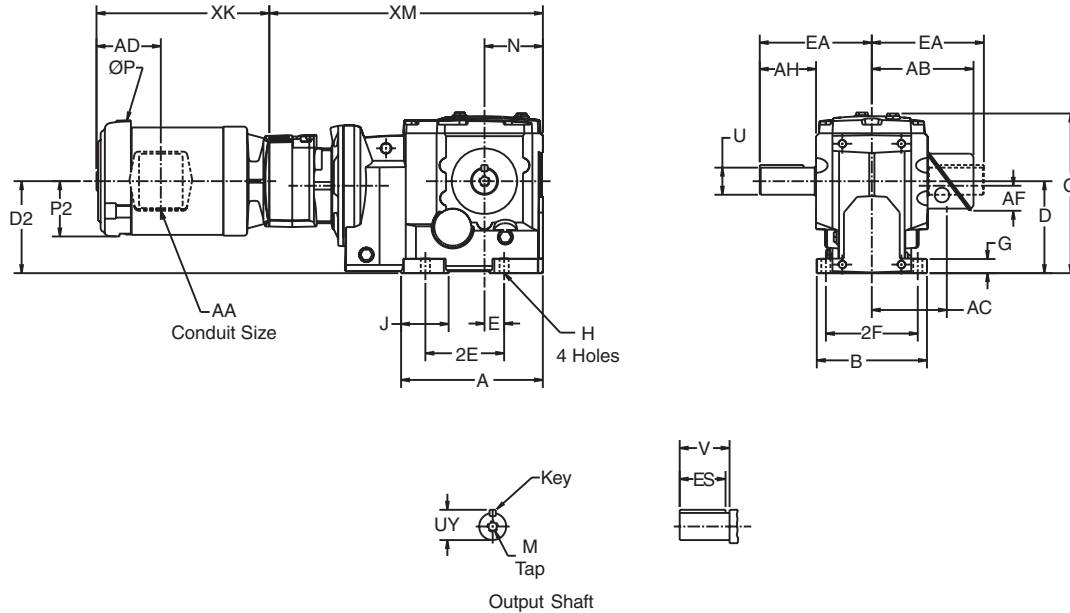

Gear Frame	Version	A	B	D ¹	D2	E	2E	2F	G	H	J	O	N	XM
34	S2	10.13	7.87	7.09	5.57	1.57	5.91	6.50	1.07	.71	2.67	12.05	4.49	21.55
	S1	10.69	9.60	6.30	7.16	4.53	9.06	7.68	1.18	.71	3.19	13.39	4.49	21.55
35	S2	11.92	8.66	8.35	6.56	2.17	7.09	7.09	1.18	.87	3.37	13.58	5.20	23.87
	S1	13.07	10.98	7.87	9.00	5.51	11.02	9.06	1.40	.87	4.05	16.22	5.20	23.87

Output Shaft

Gear Frame	Version	U ³	UY	V	AH	EA	Key	ES	M
34	S2	2.000	2.21	3.63	3.76	8.11	1/2 Sq.	3.06	3/4-10 X 1.61
	S1	1.750	1.909	3.56	3.66	8.46	3/8 Sq.	3.56	3/4-10 X 1.61
35	S2	2.375	2.638	4.61	4.74	9.45	5/8 Sq.	3.81	3/4-10 X 1.61
	S1	2.375	2.638	5.73	5.27	10.57	5/8 Sq.	4.81	3/4-10 X 1.61

Motor Frame	Motor Type ⁴	Gear Frame	P	P2	AA	AB	AC	AD	AF	XK
56	T	Any	7.31	3.31	.75	6.10	4.50	3.86	1.77	9.79
143T/145T	T	Any	7.31	3.31	.75	6.10	4.50	3.86	1.77	11.04
145TY	T	Any	7.31	3.31	.75	6.10	4.50	3.86	1.77	12.04
182T/184T	T	35	9.56	4.34	.75	6.10	4.50	5.13	1.77	14.04

¹ Dimension "D" will never be exceeded, but may vary from values shown. When exact dimensions are required, shims up to .03" may be necessary.

² All rough casting dimensions may vary by .25" due to casting variations.

³ Shaft extension tolerances: +.0000"; -.0005" for shafts up to 1.5" diameter "U". Larger diameter: "U", +.000"; -.001".

⁴ Motor dimensions for other than "TypeT" three phase TEFC motors, refer to pages B-98 - B-99.

Combined Output Shafted Foot Mount OtN26 - 28

Standard conduit box location will be opposite shaft extension unless specified otherwise.

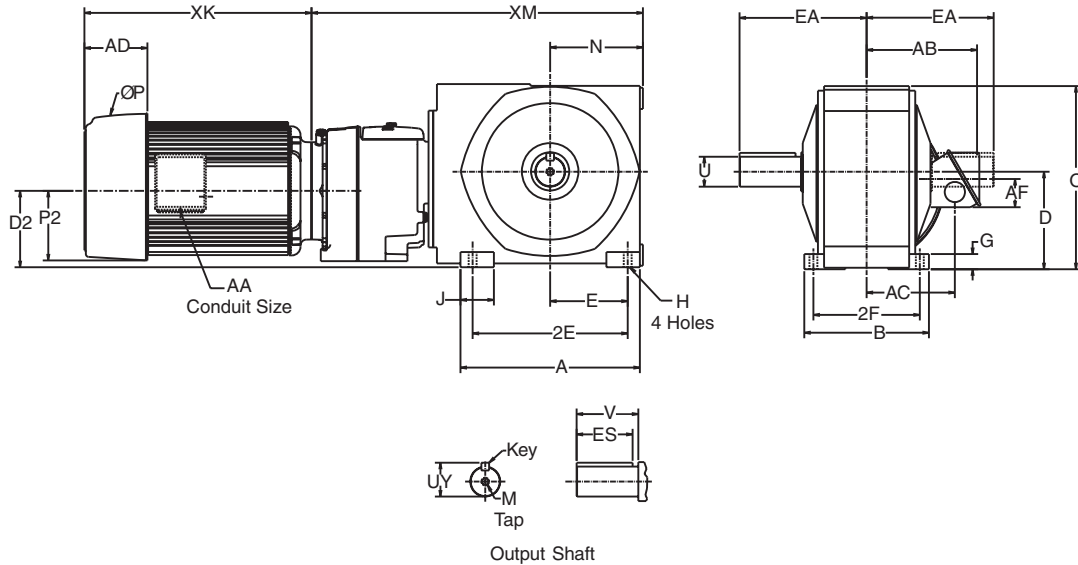

OtN Series

Gear Frame	Version	A	B	D ¹	D2	E	2E	2F	G	H	J	O	N	XM		
														56-184T	213T-215T	254T-UP
26A	S1	16.73	11.42	8.86	7.66	6.99	13.98	9.45	1.57	.87	3.54	16.65	8.74	30.80	30.80	30.80
27A	S1	19.29	12.60	9.84	7.89	8.27	16.54	10.63	1.77	.94	3.94	18.50	10.04	31.47	31.47	31.47
28A	S1	23.23	16.14	12.40	10.4	10.04	20.08	13.78	1.97	1.02	4.33	23.70	12.01	37.14	37.14	37.49

Output Shaft

Gear Frame	Version	U ³	UY	V	EA	Key	ES	M
26A	S1	2.875	3.200	5.75	12.82	3/4 Sq.	5.13	3/4-10 X 1.97
27A	S1	3.500	3.882	7.01	13.70	7/8 Sq.	6.25	1-8 X 1.97
28A	S1	3.875	4.426	7.99	17.06	1.00 Sq.	7.25	1-8 X 1.97

Motor Frame	Motor Type ⁴	Gear Frame	P	P2	AA	AB	AC	AD	AF	XK
56	T	All	7.31	3.31	.75	6.10	4.50	3.86	1.77	9.79
143T/145T	T	All	7.31	3.31	.75	6.10	4.50	3.86	1.77	11.04
145TY	T	All	7.31	3.31	.75	6.10	4.50	3.86	1.77	12.04
182T/184T	T	All	9.56	4.34	.75	6.10	4.50	5.13	1.77	14.04
213T	T	All	11.25	5.06	1.00	8.42	7.17	5.60	2.42	16.15
215T	T	All	11.25	5.06	1.00	8.42	7.17	5.60	2.42	17.65
254T	T	27A, 28A	13.38	6.00	1.25	9.79	7.68	8.29	1.81	19.61
256T	T	28A	13.38	6.00	1.25	9.79	7.68	8.29	1.81	21.36
284T	T	28A	13.38	6.00	1.50	10.58	8.18	8.29	2.13	21.86
286T	T	28A	13.38	6.00	1.50	10.33	7.93	8.29	2.13	23.36

¹ Dimension "D" will never be exceeded, but may vary from values shown. When exact dimensions are required, shims up to .03" may be necessary.

² All rough casting dimensions may vary by .25" due to casting variations.

³ Shaft extension tolerances: +.0000"; -.0005" for shafts up to 1.5" diameter "U". Larger diameter: "U", +.000"; -.001".

⁴ Motor dimensions for other than "TypeT" three phase TEFC motors, refer to pages B-98 - B-99.

3-Stage Output Shafted Flange Mount OtN32 - 33

Standard conduit box location will be opposite flange unless specified otherwise.

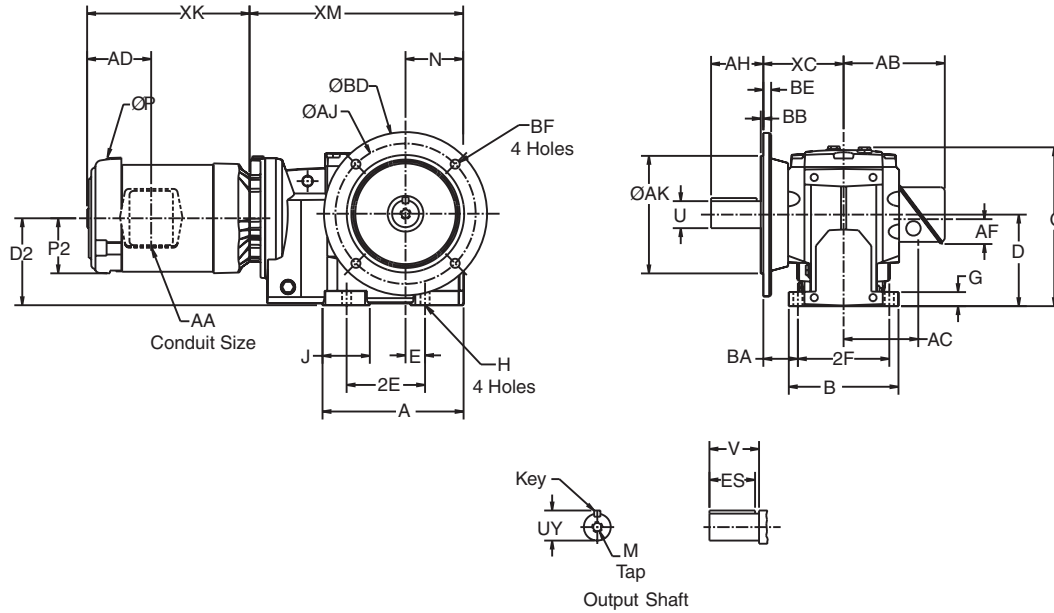

Gear Frame	Version	A	B	D ¹	D2	E	2E	2F	G	H	J	O	N	BA	XC	XM
32	S1,S2	7.81	5.71	4.41	3.78	1.38	5.12	4.71	.73	.43	2.34	8.09	3.03	1.81	4.04	10.98
33	S1,S2	8.50	6.61	5.51	5.24	1.18	4.72	5.51	.85	.55	2.86	9.69	3.54	2.24	4.84	12.90

Output Shaft

Gear Frame	Version	U ³	UY	V	AH	Key	ES	M
32	S2	1.250	1.354	2.38	2.36	1/4 Sq.	2.06	1/2-13 X 1.12
	S1	1.250	1.354	1.77	1.75	1/4 Sq.	1.45	1/2-13 X 1.12
33	S2	1.625	1.783	3.25	3.38	3/8 Sq.	2.78	5/8-11 X 1.38
	S1	1.500	1.657	3.18	2.28	3/8 Sq.	2.19	5/8-11 X 1.38

Output Flange

Gear Frame	Flange Code	AK	AJ	BB	BD	BE	BF
32	5	5.118	6.50	.14	7.87	.39	.47
	6	7.087	8.46	.16	9.84	.47	.55
33	5	7.087	8.46	.16	9.84	.47	.55
	6	9.055	10.43	.16	11.81	.47	.55

Motor Frame	Motor Type ⁴	Gear Frame	P	P2	AA	AB	AC	AD	AF	XK
56	T	Any	7.31	3.31	.75	6.10	4.50	3.86	1.77	9.79
143T/145T	T	Any	7.31	3.31	.75	6.10	4.50	3.86	1.77	11.04
145TY	T	Any	7.31	3.31	.75	6.10	4.50	3.86	1.77	12.04
182T/184T	T	Any	9.56	4.34	.75	6.10	4.50	5.13	1.77	14.04
213T	T	33	11.25	5.06	1.00	8.42	7.17	5.60	2.42	16.15
215T	T	33	11.25	5.06	1.00	8.42	7.17	5.60	2.42	17.65

¹ Dimension "D" will never be exceeded, but may vary from values shown. When exact dimensions are required, shims up to .03" may be necessary.

² All rough casting dimensions may vary by .25" due to casting variations.

³ Shaft extension tolerances: +.0000"; -.0005" for shafts up to 1.5" diameter "U". Larger diameter: "U", +.000"; -.001".

⁴ Motor dimensions for other than "TypeT" three phase TEFC motors, refer to pages B-98 - B-99.

3-Stage Output Shafted Flange Mount OtN34 - 35

Standard conduit box location will be opposite flange unless specified otherwise.

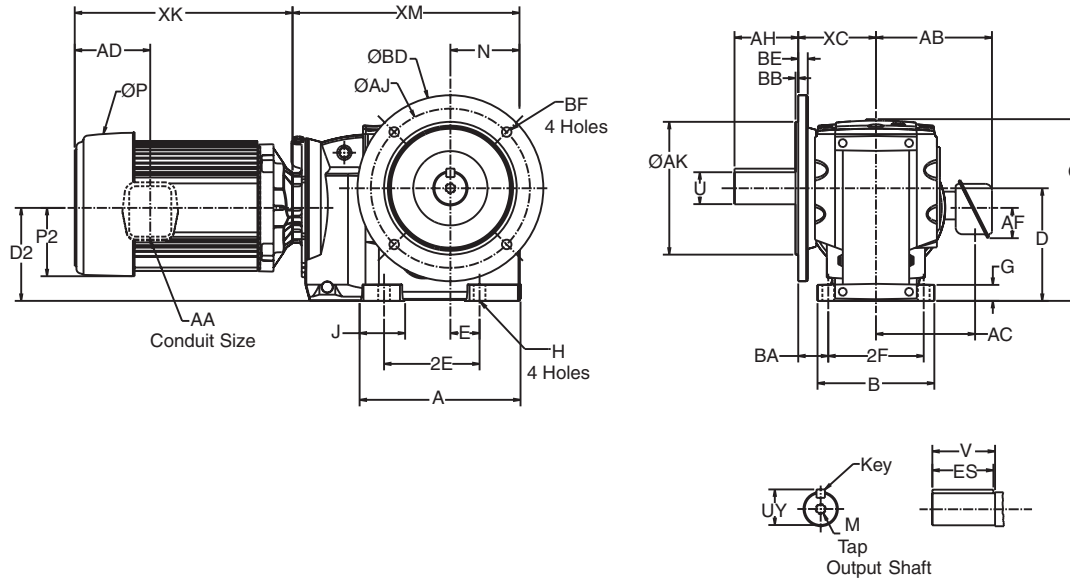

OtN Series

Gear Frame	Version	A	B	D'	D2	E	2E	2F	G	H	J	O	N	BA	XC	XM	
																56T-215T	254T-286T
34	S1,S2	10.13	7.87	7.09	5.90	1.57	5.91	6.50	1.07	.71	2.67	12.05	4.49	1.93	5.18	14.56	-
35	S2	11.92	8.66	8.35	6.89	2.17	7.09	7.09	1.19	.87	3.45	13.58	5.20	2.22	5.76	16.90	17.25

Output Shaft

Gear Frame	Version	U ³	UY	V	AH	Key	ES	M
34	S2	2.000	2.210	3.94	3.94	1/2 Sq.	3.06	3/4-10 X 1.61
	S1	1.750	1.909	3.56	3.28	3/8 Sq.	3.56	3/4-10 X 1.61
35	S2	2.375	2.638	4.72	4.72	5/8 Sq.	3.81	3/4-10 X 1.61

Output Flange

Gear Frame	Flange Code	AK	AJ	BB	BD	BE	BF
34	5	9.055	10.43	.16	11.81	.59	.55
	6	9.842	11.80	.16	13.77	.59	.71
35	5	9.842	11.80	.20	13.77	.71	.71
	6	11.810	13.77	.20	15.75	.71	.71

Motor Frame	Motor Type ⁴	Gear Frame	P	P2	AA	AB	AC	AD	AF	XK
56	T	Any	7.31	3.31	.75	6.10	4.50	3.86	1.77	9.79
143T/145T	T	Any	7.31	3.31	.75	6.10	4.50	3.86	1.77	11.04
145TY	T	Any	7.31	3.31	.75	6.10	4.50	3.86	1.77	12.04
182T/184T	T	Any	9.56	4.34	.75	6.10	4.50	5.13	1.77	14.04
213T	T	Any	11.25	5.06	1.00	8.42	7.17	5.60	2.42	16.15
215T	T	Any	11.25	5.06	1.00	8.42	7.17	5.60	2.42	17.65
254T	T	34	13.38	6.00	1.25	9.79	7.68	8.29	1.81	20.58
	T	35	13.38	6.00	1.25	9.79	7.68	8.29	1.81	19.61
256T	T	34	13.38	6.00	1.25	9.79	7.68	8.29	1.81	22.33
	T	35	13.38	6.00	1.25	9.79	7.68	8.29	1.81	21.36
284T	T	35	13.38	6.00	1.50	10.58	8.18	8.29	2.13	21.86
286T	T	35	13.38	6.00	1.50	10.33	7.93	8.29	2.13	23.36

¹ Dimension "D" will never be exceeded, but may vary from values shown. When exact dimensions are required, shims up to .03" may be necessary.

² All rough casting dimensions may vary by .25" due to casting variations.

³ Shaft extension tolerances: +.0000"; -.0005" for shafts up to 1.5" diameter "U". Larger diameter: "U", +.000"; -.001".

⁴ Motor dimensions for other than "TypeT" three phase TEFC motors, refer to pages B-98 - B-99.

3-Stage Output Shafted Flange Mount OtN26 - 28

Standard conduit box location will be opposite flange unless specified otherwise.

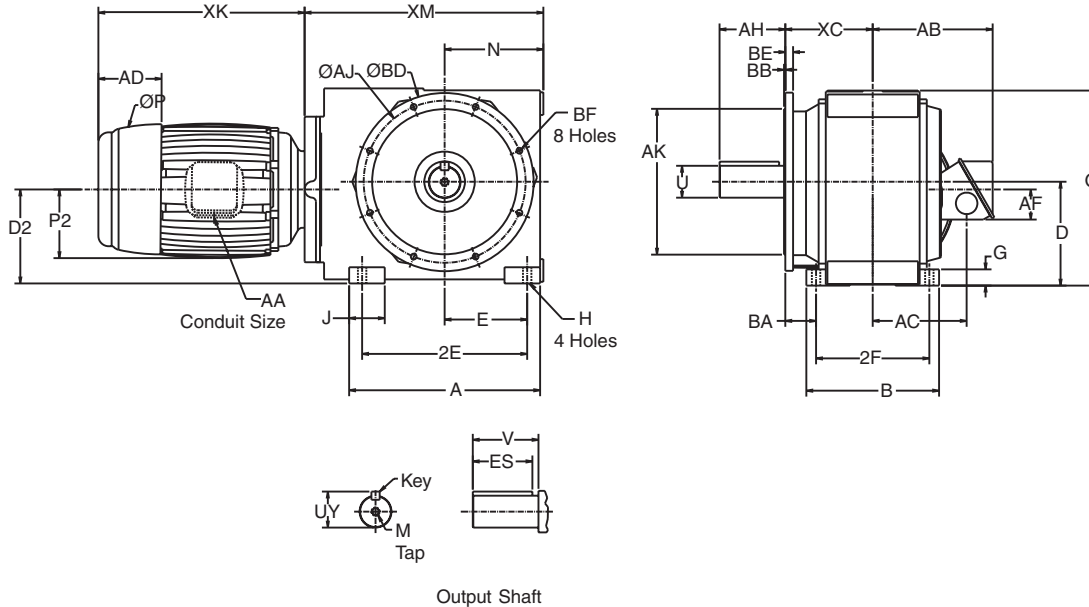

Gear Frame	Version	A	B	D ¹	D ₂	E	2E	2F	G	H	J	O	N	BA	XC	XM		
																182T-184T	213T-215T	254T-UP
26	S1	16.73	11.42	8.86	8.43	6.99	13.98	9.45	1.57	.87	3.54	16.65	8.74	3.54	9.00	23.22	24.22	22.21
27	S1	19.29	12.60	9.84	8.66	8.27	16.54	10.63	1.77	.94	3.94	18.50	10.04	3.54	8.55	25.30	26.30	24.30
28	S1	23.23	16.14	12.40	11.42	10.04	20.08	13.78	1.97	1.02	4.33	23.70	12.01	3.74	11.51	-	33.04	28.95

Output Shaft

Gear Frame	Version	U ³	UY	V	AH	Key	ES	M
26	S1	2.875	3.200	5.75	5.75	3/4 Sq.	5.13	3/4-10 X 1.97
27	S1	3.500	3.882	7.00	7.00	7/8 Sq.	6.25	1-8 X 1.97
28	S1	4.000	4.436	8.00	8.00	1.00 Sq.	7.25	1-8 X 1.97

Output Flange

Gear Frame	Flange Code	AJ	AK	BB	BD	BE	BF
26	5	15.75	13.75	.20	17.72	.79	.71
27	5	15.75	13.78	.20	17.72	.79	.71
28	5	19.69	17.72	.24	21.65	.94	.71

Motor Frame	Motor Type ⁴	Gear Frame	P	P ₂	AA	AB	AC	AD	AF	XK
182T/184T	T	26,27	9.56	4.34	.75	6.10	4.50	5.13	1.77	12.03
213T	T	All	11.25	5.06	1.00	8.42	7.17	5.60	2.42	13.75
215T	T	All	11.25	5.06	1.00	8.42	7.17	5.60	2.42	15.25
254T	T	All	13.38	6.00	1.25	9.79	7.68	8.29	1.81	19.61
256T	T	All	13.38	6.00	1.25	9.79	7.68	8.29	1.81	21.36
284T	T	All	13.38	6.00	1.50	10.58	8.18	8.29	2.13	21.86
286T	T	All	13.38	6.00	1.50	10.33	7.93	8.29	2.13	23.36
324T/326T	T	27,28	17.20	7.78	2.00	14.99	11.34	14.16	3.63	24.96
364T/365T	T	27,28	18.22	9.11	3.00	16.31	12.19	14.37	3.38	26.13

¹ Dimension "D" will never be exceeded, but may vary from values shown. When exact dimensions are required, shims up to .03" may be necessary.

² All rough casting dimensions may vary by .25" due to casting variations.

³ Shaft extension tolerances: +.0000"; -.0005" for shafts up to 1.5" diameter "U". Larger diameter: "U", +.000"; -.001".

⁴ Motor dimensions for other than "TypeT" three phase TEFC motors, refer to pages B-98 - B-99.

Combined Output Shafted Flange Mount OtN32 - 33

Standard conduit box location will be opposite flange unless specified otherwise.

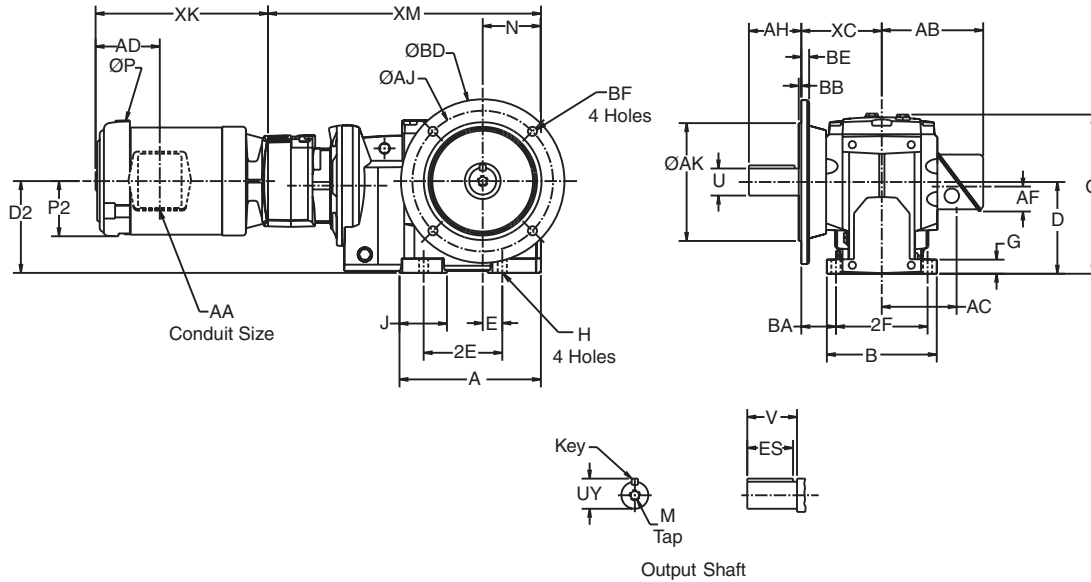

OtN Series

Gear Frame	Version	A	B	D ¹	D2	E	2E	2F	G	H	J	O	N	BA	XC	XM
32	S1,S2	7.81	5.71	4.41	4.06	1.38	5.12	4.71	.73	.43	2.34	8.09	3.03	1.81	4.04	14.49
33	S1,S2	8.50	6.61	5.51	4.91	1.18	4.72	5.51	.85	.55	2.86	9.69	3.54	2.24	4.84	19.90

Output Shaft

Gear Frame	Version	U ³	UY	V	AH	Key	ES	M
32	S2	1.250	1.354	2.38	2.36	1/4 Sq.	2.06	1/2-13 X 1.12
	S1	1.250	1.354	1.77	1.75	1/4 Sq.	1.45	1/2-13 X 1.12
33	S2	1.625	1.783	3.25	3.38	3/8 Sq.	2.78	5/8-11 X 1.38
	S1	1.500	1.657	3.18	2.28	3/8 Sq.	2.19	5/8-11 X 1.38

Output Flange

Gear Frame	Flange Code	AK	AJ	BB	BD	BE	BF
32	5	5.118	6.50	.14	7.87	.39	.47
	6	7.087	8.46	.16	9.84	.47	.55
33	5	7.087	8.46	.16	9.84	.47	.55
	6	9.055	10.43	.16	11.81	.47	.55

Motor Frame	Motor Type ⁴	Gear Frame	P	P2	AA	AB	AC	AD	AF	XK
56	T	32	7.31	3.31	.75	6.10	4.50	3.86	1.77	10.37
		33	7.31	3.31	.75	6.10	4.50	3.86	1.77	9.79
143T/145T	T	32	7.31	3.31	.75	6.10	4.50	3.86	1.77	11.62
		33	7.31	3.31	.75	6.10	4.50	3.86	1.77	11.04
145TY	T	33	7.31	3.31	.75	6.10	4.50	3.86	1.77	12.04

¹ Dimension "D" will never be exceeded, but may vary from values shown. When exact dimensions are required, shims up to .03" may be necessary.

² All rough casting dimensions may vary by .25" due to casting variations.

³ Shaft extension tolerances: +.0000"; -.0005" for shafts up to 1.5" diameter "U". Larger diameter: "U", +.000"; -.001".

⁴ Motor dimensions for other than "TypeT" three phase TEFC motors, refer to pages B-98 - B-99.

Combined Output Shafted Flange Mount OtN34 - 35

Standard conduit box location will be opposite flange unless specified otherwise.

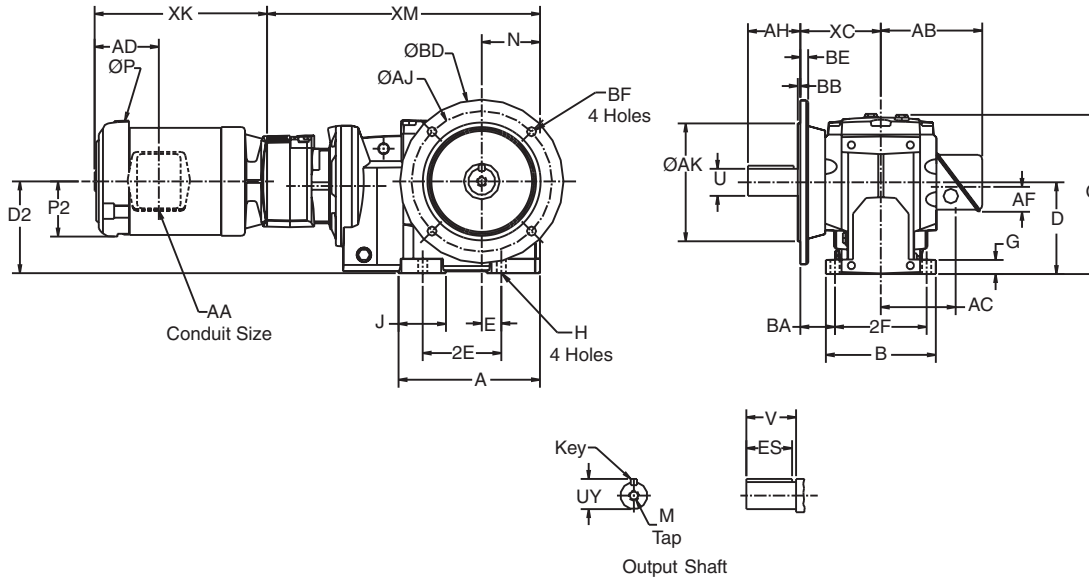

Gear Frame	Version	A	B	D ¹	D2	E	2E	2F	G	H	J	O	N	BA	XC	XM
34	S1, S2	10.13	7.87	7.09	5.57	1.57	5.91	6.50	1.07	.71	2.67	12.05	4.49	1.93	5.18	21.55
35	S2	11.92	8.66	8.35	6.56	2.17	7.09	7.09	1.19	.87	3.45	13.58	5.20	2.22	5.76	23.87

Output Shaft

Gear Frame	Version	U ³	UY	V	AH	Key	ES	M
34	S2	2.000	2.21	3.94	3.94	1/2 Sq.	3.06	3/4-10 X 1.61
	S1	1.750	1.909	3.56	3.28	3/8 Sq.	3.56	3/4-10 X 1.61
35	S2	2.375	2.638	4.72	4.72	5/8 Sq.	3.81	3/4-10 X 1.61

Output Flange

Gear Frame	Flange Code	AK	AJ	BB	BD	BE	BF
34	5	9.055	10.43	.16	11.81	.59	.55
	6	9.842	11.80	.16	13.77	.59	.71
35	5	9.842	11.80	.20	13.77	.71	.71
	6	11.810	13.77	.20	15.75	.71	.71

Motor Frame	Motor Type ⁴	Gear Frame	P	P2	AA	AB	AC	AD	AF	XK
56	T	Any	7.31	3.31	.75	6.10	4.50	3.86	1.77	9.79
143T/145T	T	Any	7.31	3.31	.75	6.10	4.50	3.86	1.77	11.04
145TY	T	Any	7.31	3.31	.75	6.10	4.50	3.86	1.77	12.04
182T/184T	T	35	9.56	4.34	.75	6.10	4.50	5.13	1.77	14.04

¹ Dimension "D" will never be exceeded, but may vary from values shown. When exact dimensions are required, shims up to .03" may be necessary.

² All rough casting dimensions may vary by .25" due to casting variations.

³ Shaft extension tolerances: +.0000"; -.0005" for shafts up to 1.5" diameter "U". Larger diameter: "U", +.000"; -.001".

⁴ Motor dimensions for other than "TypeT" three phase TEFC motors, refer to pages B-98 - B-99.

Combined Output Shafted Flange Mount OtN26 - 28

Standard conduit box location will be opposite flange unless specified otherwise.

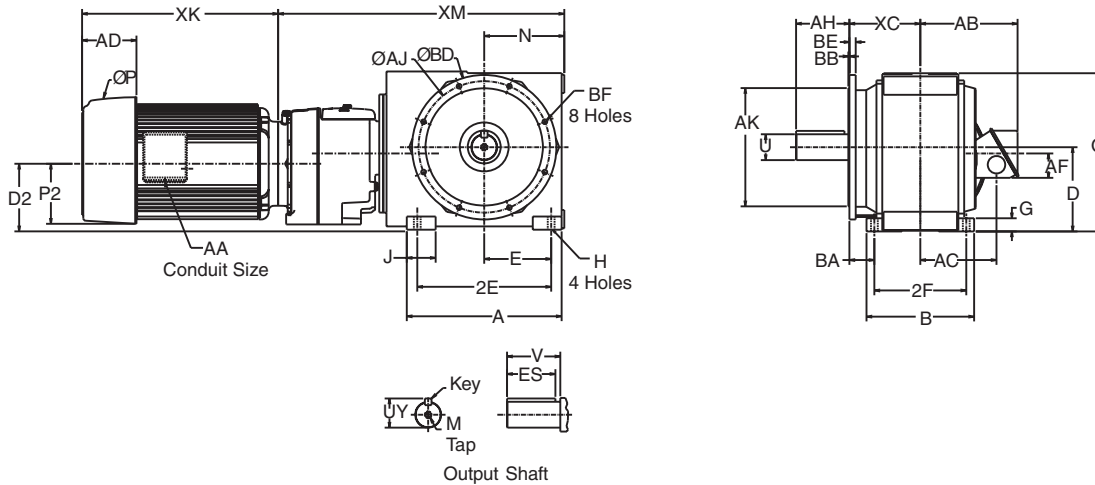

OtN Series

Gear Frame	Version	A	B	D'	D2	E	2E	2F	G	H	J	O	N	BA	XC	XM		
																56-184T	213T-215T	254T-UP
26A	S1	16.73	11.42	8.86	7.66	6.99	13.98	9.45	1.57	.87	3.54	16.65	8.74	3.54	9.00	30.80	30.80	30.80
27A	S1	19.29	12.60	9.84	7.89	8.27	16.54	10.63	1.77	.94	3.94	18.50	10.04	3.54	8.55	31.47	31.47	31.47
28A	S1	23.23	16.14	12.40	10.40	10.04	20.08	13.78	1.97	1.02	4.33	23.70	12.01	3.74	11.51	37.14	37.14	37.49

Output Shaft

Gear Frame	Version	U ³	UY	V	AH	Key	ES	M
26A	S1	2.875	3.200	5.75	5.75	3/4 Sq.	5.13	3/4-10 X 1.97
27A	S1	3.500	3.882	7.00	7.00	7/8 Sq.	6.25	1-8 X 1.97
28A	S1	4.000	4.436	8.00	8.00	1.00 Sq.	7.25	1-8 X 1.97

Output Flange

Gear Frame	Flange Code	AJ	AK	BB	BD	BE	BF
26A	5	15.75	13.75	.20	17.72	.79	.71
27A	5	15.75	13.78	.20	17.72	.79	.71
28A	5	19.69	17.72	.24	21.65	.94	.71

Motor Frame	Motor Type ⁴	Gear Frame	P	P2	AA	AB	AC	AD	AF	XK
56	T	All	7.31	3.31	.75	6.10	4.50	3.86	1.77	9.79
143T/145T	T	All	7.31	3.31	.75	6.10	4.50	3.86	1.77	11.04
145TY	T	All	7.31	3.31	.75	6.10	4.50	3.86	1.77	12.04
182T/184T	T	All	9.56	4.34	.75	6.10	4.50	5.13	1.77	14.04
213T	T	All	11.25	5.06	1.00	8.42	7.17	5.60	2.42	16.15
215T	T	All	11.25	5.06	1.00	8.42	7.17	5.60	2.42	17.65
254T	T	27A,28A	13.38	6.00	1.25	9.79	7.68	8.29	1.81	19.61
256T	T	28A	13.38	6.00	1.25	9.79	7.68	8.29	1.81	21.36
284T	T	28A	13.38	6.00	1.50	10.58	8.18	8.29	2.13	21.86
286T	T	28A	13.38	6.00	1.50	10.33	7.93	8.29	2.13	23.36

¹ Dimension "D" will never be exceeded, but may vary from values shown. When exact dimensions are required, shims up to .03" may be necessary.

² All rough casting dimensions may vary by .25" due to casting variations.

³ Shaft extension tolerances: +.0000"; -.0005" for shafts up to 1.5" diameter "U". Larger diameter: "U", +.000"; -.001".

⁴ Motor dimensions for other than "TypeT" three phase TEFC motors, refer to pages B-98 - B-99.

3-Stage Finished Bore Hollow Shaft OtN32 - 33

Standard conduit box location will be F1 unless specified otherwise.

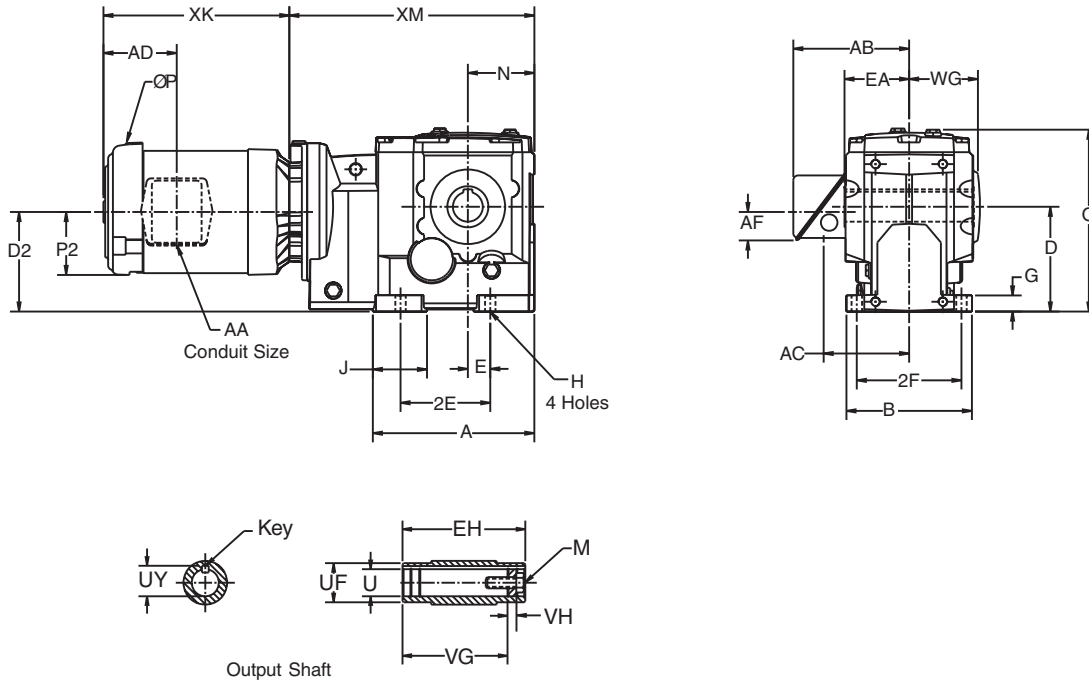

Gear Frame	Version	A	B	D ¹	D2	E	2E	2F	G	H	J	O	N	WG	XM
32	S2	7.81	5.71	4.41	3.78	1.38	5.12	4.71	.73	.43	2.34	8.09	3.03	3.22	10.98
33	S2	8.50	6.61	5.51	5.24	1.18	4.72	5.51	.85	.55	2.86	9.69	3.54	3.73	12.90

Output Shaft

Gear Frame	Version	EA	EH	U ^{3,7}	UF	UY	VG	VH	Key ⁵	M
32	S2	2.98	5.95	1.375	1.96	1.523	5.20	.55	5/16 X 5/16 X 1 13/16	1/2-13 X 1.00
33	S2	3.47	6.94	1.500	2.16	1.674	5.96	.55	3/8 X 3/8 X 2 1/4	5/8-11 X 1.75

Motor Frame	Motor Type ⁸	Gear Frame	P	P2	AA	AB	AC	AD	AF	XK
56	T	Any	7.31	3.31	.75	6.10	4.50	3.86	1.77	9.79
143T/145T	T	Any	7.31	3.31	.75	6.10	4.50	3.86	1.77	11.04
145TY	T	Any	7.31	3.31	.75	6.10	4.50	3.86	1.77	12.04
182T/184T	T	Any	9.56	4.34	.75	6.10	4.50	5.13	1.77	14.04
213T	T	33	11.25	5.06	1.00	8.42	7.17	5.60	2.42	16.15
215T	T	33	11.25	5.06	1.00	8.42	7.17	5.60	2.42	17.65

¹ Dimension "D" will never be exceeded, but may vary from values shown. When exact dimensions are required, shims up to .03" may be necessary.

² All rough casting dimensions may vary by .25" due to casting variations.

³ Refer to page B-24 by gear frame for Tapered Bushed designs if driven shaft varies from "U" dimensions offered above.

⁴ Driven shaft entry can be from either side of the gear reducer housing by reversing positioning of the snap rings and washer illustrated.

⁵ Output key supplied only on frame 34 in "S2" version.

⁶ For details of the torque arm kit, refer to page B-22.

⁷ Output bore tolerance: +.0020", -.0000" for all diameters.

⁸ Motor dimensions for other than "Type T" three phase TEFC motors, refer to pages B-98 - B-99.

3-Stage Finished Bore Hollow Shaft OtN34 - 35

Standard conduit box location will be F1 unless specified otherwise.

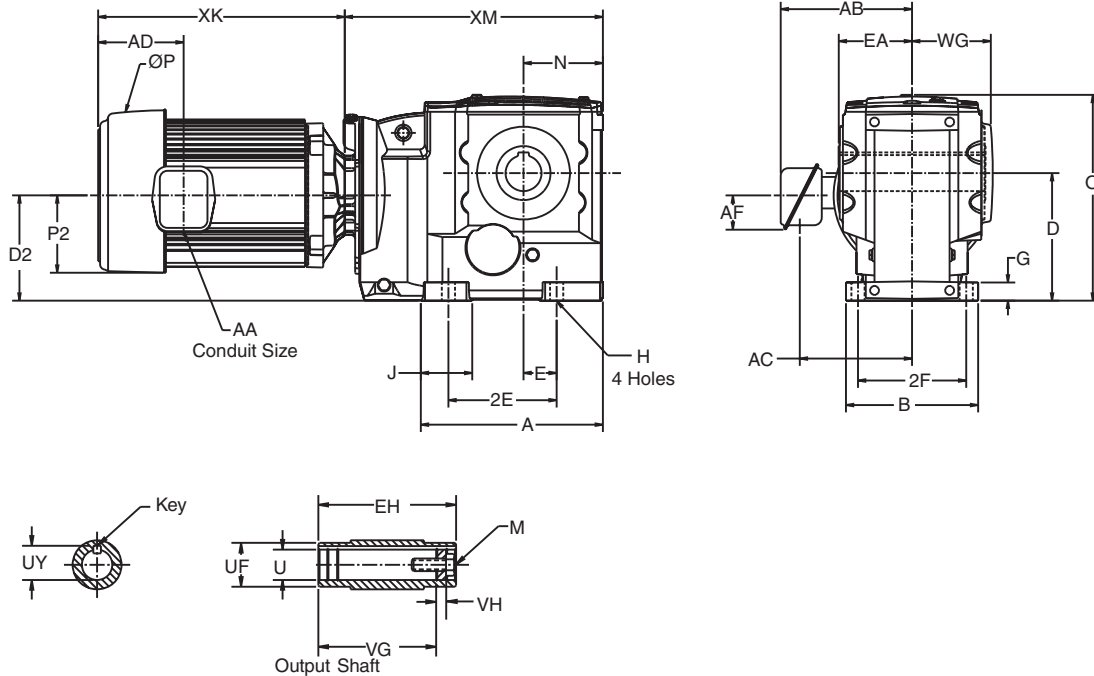

OtN Series

Gear Frame	Version	A	B	D ¹	D2	E	2E	2F	G	H	J	O	N	WG	XM	
															56T-215T	254T-286T
34	S2	10.13	7.87	7.09	5.90	1.57	5.91	6.50	1.07	.71	2.67	12.05	4.49	4.66	14.56	-
35	S2	11.92	8.66	8.35	6.89	2.17	7.09	7.09	1.18	.87	3.45	13.58	5.20	5.15	16.90	17.25

Output Shaft

Gear Frame	Version	EA	EH	U ³ 7	UF	UY	VG	VH	Key ⁵	M
34	S2	4.49	8.97	2.000	2.56	2.210	7.44	.79	1/2 X 7/16 X 2 5/8	5/8-11 X 1.75
35	S2	4.83	9.66	2.375	3.54	2.656	8.15	.94	5/8 X 5/8 X 3 5/8	3/4-10 X 2.00

Motor Frame	Motor Type ⁸	Gear Frame	P	P2	AA	AB	AC	AD	AF	XK
56	T	Any	7.31	3.31	.75	6.10	4.50	3.86	1.77	9.79
143T/145T	T	Any	7.31	3.31	.75	6.10	4.50	3.86	1.77	11.04
145TY	T	Any	7.31	3.31	.75	6.10	4.50	3.86	1.77	12.04
182T/184T	T	Any	9.56	4.34	.75	6.10	4.50	5.13	1.77	14.04
213T	T	Any	11.25	5.06	1.00	8.42	7.17	5.60	2.42	16.15
215T	T	Any	11.25	5.06	1.00	8.42	7.17	5.60	2.42	17.65
254T	T	34	13.38	6.00	1.25	9.79	7.68	8.29	1.81	20.58
	T	35	13.38	6.00	1.25	9.79	7.68	8.29	1.81	19.61
256T	T	34	13.38	6.00	1.25	9.79	7.68	8.29	1.81	22.33
	T	35	13.38	6.00	1.25	9.79	7.68	8.29	1.81	21.36
284T	T	35	13.38	6.00	1.50	10.58	8.18	8.29	2.13	21.86
286T	T	35	13.38	6.00	1.50	10.33	7.93	8.29	2.13	23.36

¹ Dimension "D" will never be exceeded, but may vary from values shown. When exact dimensions are required, shims up to .03" may be necessary.

² All rough casting dimensions may vary by .25" due to casting variations.

³ Refer to page B-24 by gear frame for Tapered Bushed designs if driven shaft varies from "U" dimensions offered above.

⁴ Driven shaft entry can be from either side of the gear reducer housing by reversing positioning of the snap rings and washer illustrated.

⁵ Output key supplied only on frame 34 in "S2" version.

⁶ For details of the torque arm kit, refer to page B-22.

⁷ Output bore tolerance: +.0020", - .0000" for all diameters.

⁸ Motor dimensions for other than "Type T" three phase TEFC motors, refer to pages B-98 - B-99.

3-Stage Finished Bore Hollow Shaft OtN26 - 28

Standard conduit box location will be F1 unless specified otherwise.

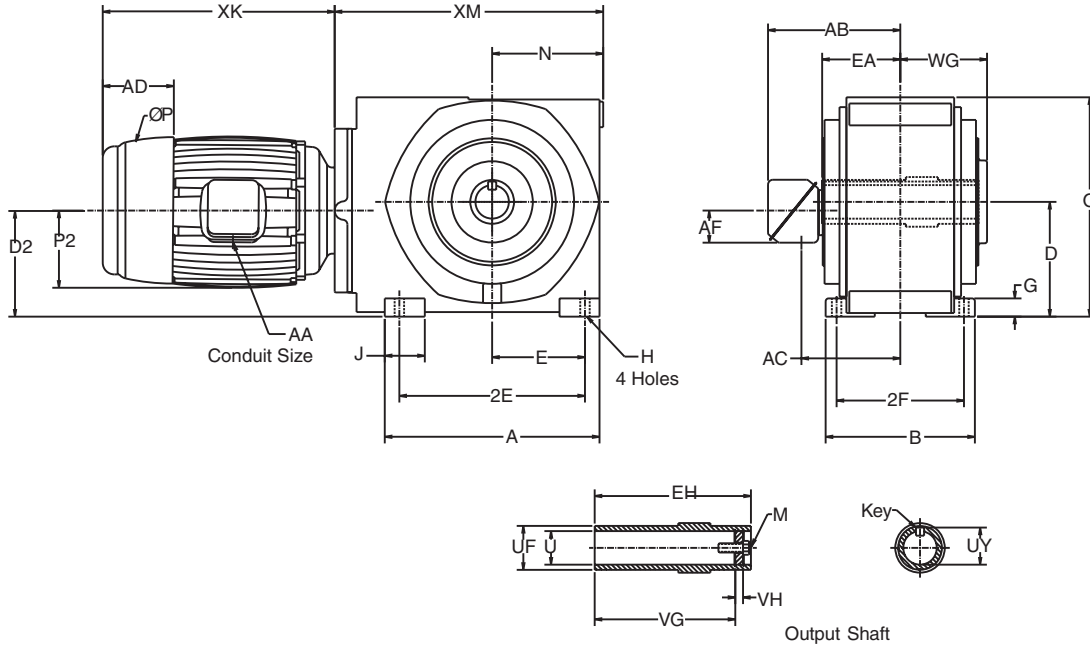

Gear Frame	Version	A	B	D ¹	D2	E	2E	2F	G	H	J	O	N	WG	XM		
															182T-184T	213T-215T	254T-UP
26	S1	16.73	11.42	8.86	8.43	6.99	13.98	9.45	1.57	.87	3.54	16.65	8.74	6.97	23.22	24.22	22.21
27	S1	19.29	12.60	9.84	8.66	8.27	16.54	10.63	1.77	.94	3.94	18.50	10.04	7.72	25.30	26.30	24.30
28	S1	23.23	16.14	12.40	11.42	10.04	20.08	13.78	1.97	1.02	4.33	23.70	12.01	9.49	-	33.04	28.95

Output Shaft

Gear Frame	Version	EA	EH	U ⁶	UF	UY	VG	VH	Key ⁴	M
26	S1	6.10	12.20	2.750	3.35	3.027	10.25	.91	5/8 Sq.	3/4-10
27	S1	6.70	13.40	3.125	3.75	3.454	11.40	.91	3/4 Sq.	3/4-10
28	S1	8.45	16.90	3.625	4.35	4.009	14.95	1.02	7/8 Sq.	1-8

Motor Frame	Motor Type ⁷	Gear Frame	P	P2	AA	AB	AC	AD	AF	XK
182T/184T	T	26,27	9.56	4.34	.75	6.10	4.50	5.13	1.77	12.03
213T	T	All	11.25	5.06	1.00	8.42	7.17	5.60	2.42	13.75
215T	T	All	11.25	5.06	1.00	8.42	7.17	5.60	2.42	15.25
254T	T	All	13.38	6.00	1.25	9.79	7.68	8.29	1.81	19.61
256T	T	All	13.38	6.00	1.25	9.79	7.68	8.29	1.81	21.36
284T	T	All	13.38	6.00	1.50	10.58	8.18	8.29	2.13	21.86
286T	T	All	13.38	6.00	1.50	10.33	7.93	8.29	2.13	23.36
324T/326T	T	27,28	17.20	7.78	2.00	14.99	11.34	14.16	3.63	24.96
364T/365T	T	27,28	18.22	9.11	3.00	16.31	12.19	14.37	3.38	26.13

¹ Dimension "D" will never be exceeded, but may vary from values shown. When exact dimensions are required, shims up to .03" may be necessary.
² All rough casting dimensions may vary by .25" due to casting variations.
³ Driven shaft entry can be from either side of the gear reducer housing by reversing positioning of the snap rings and washer illustrated.

⁴ Output key supplied only on frame 34 in "S2" version.
⁵ For details of the torque arm kit, refer to page B-23.
⁶ Output bore tolerance: +.0020", -.0000" for all diameters.
⁷ Motor dimensions for other than "Type T" three phase TEFC motors, refer to pages B-98 - B-99.

Combined Finished Bore Hollow Shaft OtN32 - 33

Standard conduit box location will be F1 unless specified otherwise.

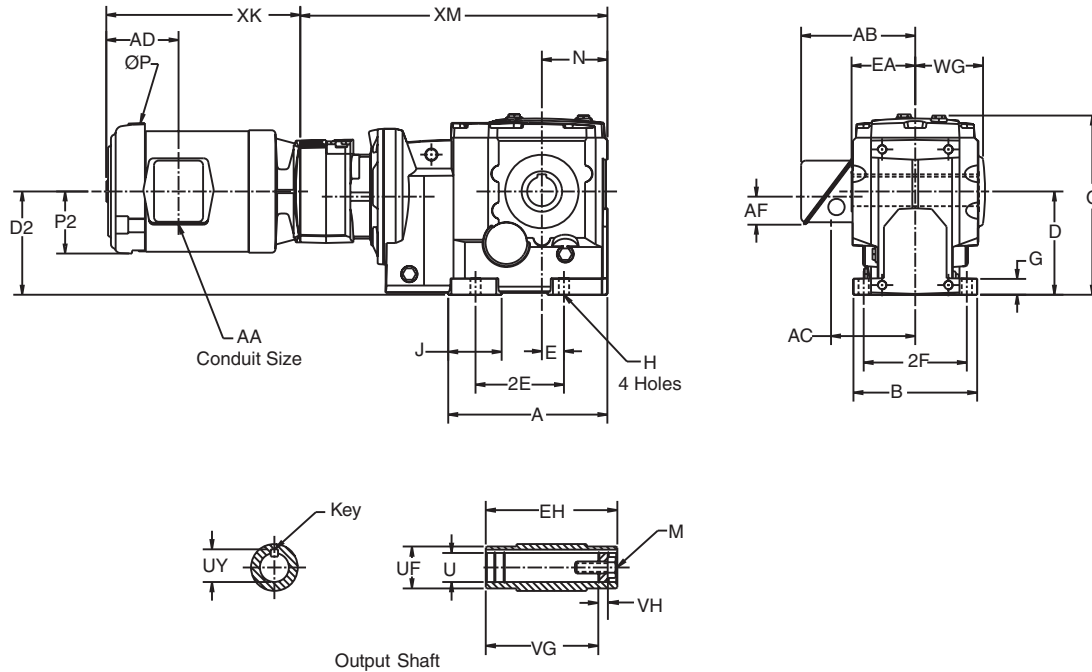

OtN Series

Gear Frame	Version	A	B	D ¹	D2	E	2E	2F	G	H	J	O	N	WG	XM
32	S2	7.81	5.71	4.41	4.06	1.38	5.12	4.71	.73	.43	2.34	8.09	3.03	3.22	14.49
33	S2	8.50	6.61	5.51	4.91	1.18	4.72	5.51	.85	.55	2.86	9.69	3.54	3.73	19.90

Output Shaft

Gear Frame	Version	EA	EH	U ^{3 6}	UF	UY	VG	VH	Key	M
32	S2	2.98	5.96	1.375	1.96	1.523	5.20	.55	5/16 X 5/16 X 1 13/16	1/2-13 X 1.00
33	S2	3.47	6.94	1.500	2.16	1.674	5.96	.55	3/8 X 3/8 X 2 1/4	5/8-11 X 1.75

Motor Frame	Motor Type ⁷	Gear Frame	P	P2	AA	AB	AC	AD	AF	XK
56	T	32	7.31	3.31	.75	6.10	4.50	3.86	1.77	10.37
	T	33	7.31	3.31	.75	6.10	4.50	3.86	1.77	9.79
143T/145T	T	32	7.31	3.31	.75	6.10	4.50	3.86	1.77	11.62
	T	33	7.31	3.31	.75	6.10	4.50	3.86	1.77	11.04
145TY	T	33	7.31	3.31	.75	6.10	4.50	3.86	1.77	12.04

¹ Dimension "D" will never be exceeded, but may vary from values shown. When exact dimensions are required, shims up to .03" may be necessary.
² All rough casting dimensions may vary by .25" due to casting variations.
³ Refer to page B-24 by gear frame for Tapered Bushed designs if driven shaft varies from "U" dimensions offered above.
⁴ Driven shaft entry can be from either side of the gear reducer housing by reversing positioning of the snap rings and washer illustrated.
⁵ For details of the torque arm kit, refer to page B-22.
⁶ Output bore tolerance: +.0020", -.0000" for all diameters.
⁷ Motor dimensions for other than "Type T" three phase TEFC motors, refer to pages B-98 - B-99.

Combined Finished Bore Hollow Shaft OtN34 - 35

Standard conduit box location will be F1 unless specified otherwise.

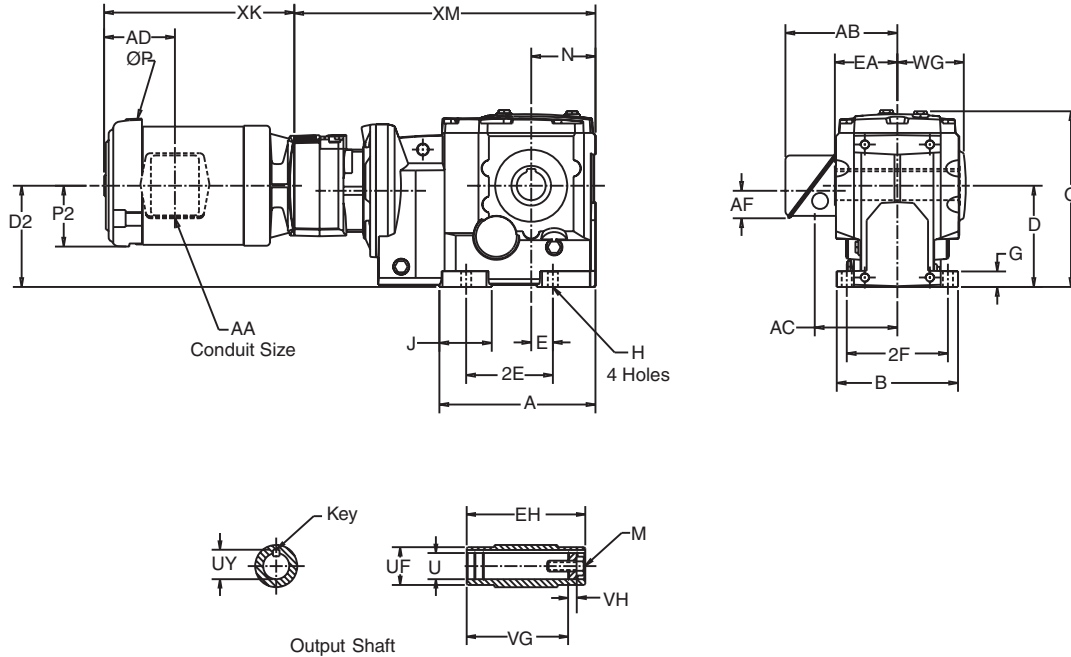

Gear Frame	Version	A	B	D ¹	D ₂	E	2E	2F	G	H	J	O	N	WG	XM
34	S2	10.13	7.87	7.09	5.57	1.57	5.91	6.50	1.07	.71	2.67	12.05	4.49	4.66	21.55
35	S2	11.92	8.66	8.35	6.56	2.17	7.09	7.09	1.18	.87	3.45	13.58	5.20	5.15	23.87

Output Shaft

Gear Frame	Version	EA	EH	U ³ 7	UF	UY	VG	VH	Key ⁵	M
34	S2	4.49	8.97	2.000	2.56	2.210	7.44	.79	1/2 X 7/16 X 2 5/8	5/8-11 X 1.75
35	S2	4.83	9.66	2.375	3.54	2.656	8.15	.94	5/8 X 5/8 X 3 5/8	3/4-10 X 2.00

Motor Frame	Motor Type ⁸	Gear Frame	P	P ₂	AA	AB	AC	AD	AF	XK
56	T	Any	7.31	3.31	.75	6.10	4.50	3.86	1.77	9.79
143T/145T	T	Any	7.31	3.31	.75	6.10	4.50	3.86	1.77	11.04
145TY	T	Any	7.31	3.31	.75	6.10	4.50	3.86	1.77	12.04
182T/184T	T	35	9.56	4.34	.75	6.10	4.50	5.13	1.77	14.04

¹ Dimension "D" will never be exceeded, but may vary from values shown. When exact dimensions are required, shims up to .03" may be necessary.
² All rough casting dimensions may vary by .25" due to casting variations.
³ Refer to page B-24 by gear frame for Tapered Bushed designs if driven shaft varies from "U" dimensions offered above.
⁴ Driven shaft entry can be from either side of the gear reducer housing by reversing positioning of the snap rings and washer illustrated.

⁵ Output key supplied only on frame 34 in "S2" version.
⁶ For details of the torque arm kit, refer to page B-22.
⁷ Output bore tolerance: +.0020", -.0000" for all diameters.
⁸ Motor dimensions for other than "Type T" three phase TEFC motors, refer to pages B-98 - B-99.

Combined Finished Bore Hollow Shaft OtN26 - 28

Standard conduit box location will be F1 unless specified otherwise.

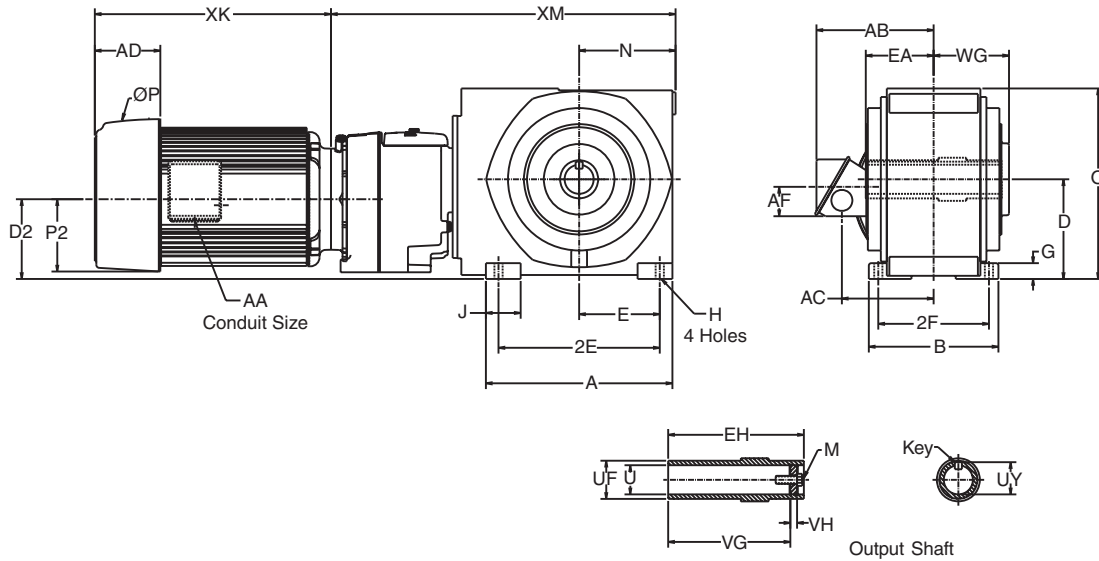

OtN Series

Gear Frame	Version	A	B	D ¹	D2	E	2E	2F	G	H	J	O	N	WG	XM		
															56-184T	213T-215T	254T-UP
26A	S1	16.73	11.42	8.86	7.66	6.99	13.98	9.45	1.57	.87	3.54	16.65	8.74	6.97	30.80	30.80	30.80
27A	S1	19.29	12.60	9.84	7.89	8.27	16.54	10.63	1.77	.94	3.94	18.50	10.04	7.72	31.47	31.47	31.47
28A	S1	23.23	16.14	12.40	10.40	10.04	20.08	13.78	1.97	1.02	4.33	23.70	12.01	9.49	37.14	37.14	37.49

Output Shaft

Gear Frame	Version	EA	EH	U ⁵	UF	UY	VG	VH	Key	M
26A	S1	6.10	12.20	2.750	3.35	3.027	10.25	.91	5/8 Sq.	3/4-10
27A	S1	6.70	13.40	3.125	3.75	3.454	11.40	.91	3/4 Sq.	3/4-10
28A	S1	8.45	16.90	3.625	4.35	4.009	14.95	1.02	7/8 Sq.	1-8

Motor Frame	Motor Type ⁶	Gear Frame	P	P2	AA	AB	AC	AD	AF	XK
56	T	All	7.31	3.31	.75	6.10	4.50	3.86	1.77	9.79
143T/145T	T	All	7.31	3.31	.75	6.10	4.50	3.86	1.77	11.04
145TY	T	All	7.31	3.31	.75	6.10	4.50	3.86	1.77	12.04
182T/184T	T	All	9.56	4.34	.75	6.10	4.50	5.13	1.77	14.04
213T	T	All	11.25	5.06	1.00	8.42	7.17	5.60	2.42	16.15
215T	T	All	11.25	5.06	1.00	8.42	7.17	5.60	2.42	17.65
254T	T	27A,28A	13.38	6.00	1.25	9.79	7.68	8.29	1.81	19.61
256T	T	28A	13.38	6.00	1.25	9.79	7.68	8.29	1.81	21.36
284T	T	28A	13.38	6.00	1.50	10.58	8.18	8.29	2.13	21.86
286T	T	28A	13.38	6.00	1.50	10.33	7.93	8.29	2.13	23.36

¹ Dimension "D" will never be exceeded, but may vary from values shown. When exact dimensions are required, shims up to .03" may be necessary.
² All rough casting dimensions may vary by .25" due to casting variations.
³ Driven shaft entry can be from either side of the gear reducer housing by reversing positioning of the snap rings and washer illustrated.
⁴ For details of the torque arm kit, refer to page B-23.
⁵ Output bore tolerance: +.0020", -.0000" for all diameters.
⁶ Motor dimensions for other than "Type T" three phase TEFC motors, refer to pages B-98 - B-99.

3-Stage Finished Bore Hollow Shaft Face Mount - OtN32 - 33

Standard conduit box location will be opposite face mounting unless specified otherwise.

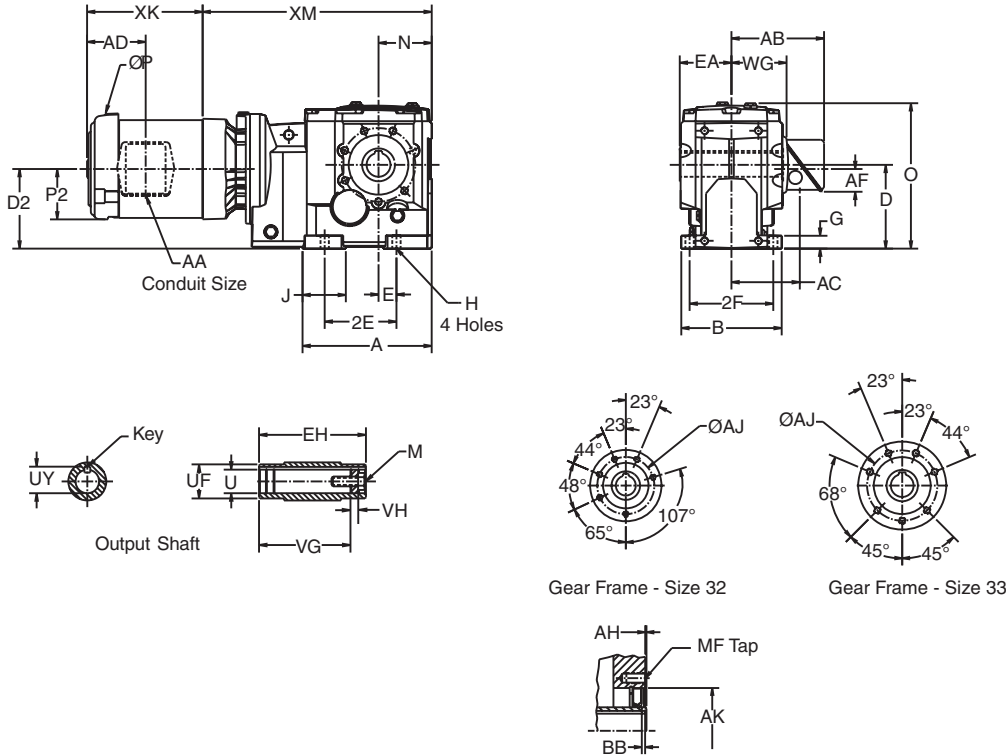

Gear Frame	Version	A	B	D ¹	D2	E	2E	2F	G	H	J	O	N	WG	XM
32	S2	7.81	5.71	4.41	3.78	1.38	5.12	4.71	.73	.43	2.34	8.09	3.03	3.15	10.98
33	S2	8.50	6.61	5.51	5.24	1.18	4.72	5.51	.85	.55	2.86	9.69	3.54	3.63	12.90

Output Shaft

Gear Frame	Version	EA	EH	U ⁵	UF	UY	VG	VH	Key	M
32	S2	2.98	5.95	1.375	1.96	1.523	5.20	.55	5/16 X 5/16 X 1 13/16	1/2-13 X 1.00
33	S2	3.47	6.94	1.500	2.16	1.674	5.96	.55	3/8 X 3/8 X 2 1/4	5/8-11 X 1.75

Face Mount

Gear Frame	Flange Code	AH	AJ	AK	BB	MF
32	S2	.12	3.94	3.15	.16	M10 X .87
33	S2	.12	4.84	3.94	.16	M12 X .87

Motor Frame	Motor Type ³	Gear Frame	P	P2	AA	AB	AC	AD	AF	XK
56	T	Any	7.31	3.31	.75	6.10	4.50	3.86	1.77	9.79
143T/145T	T	Any	7.31	3.31	.75	6.10	4.50	3.86	1.77	11.04
145TY	T	Any	7.31	3.31	.75	6.10	4.50	3.86	1.77	12.04
182T/184T	T	Any	9.56	4.34	.75	6.10	4.50	5.13	1.77	14.04
213T	T	33	11.25	5.06	1.00	8.42	7.17	5.60	2.42	16.15
215T	T	33	11.25	5.06	1.00	8.42	7.17	5.60	2.42	17.65

¹ Dimension "D" will never be exceeded, but may vary from values shown. When exact dimensions are required, shims up to .03" may be necessary.
² All rough casting dimensions may vary by .25" due to casting variations.
³ Motor dimensions for other than "Type T" three phase TEFC motors, refer to pages B-98 - B-99.
⁴ Driven shaft entry can be from either side of the gear reducer housing by reversing positioning of the snap rings and washer illustrated.
⁵ Output bore tolerance: +.0020", -.0000" for all diameters.

3-Stage Finished Bore Hollow Shaft Face Mount - OtN34 - 35

Standard conduit box location will be opposite face mounting unless specified otherwise.

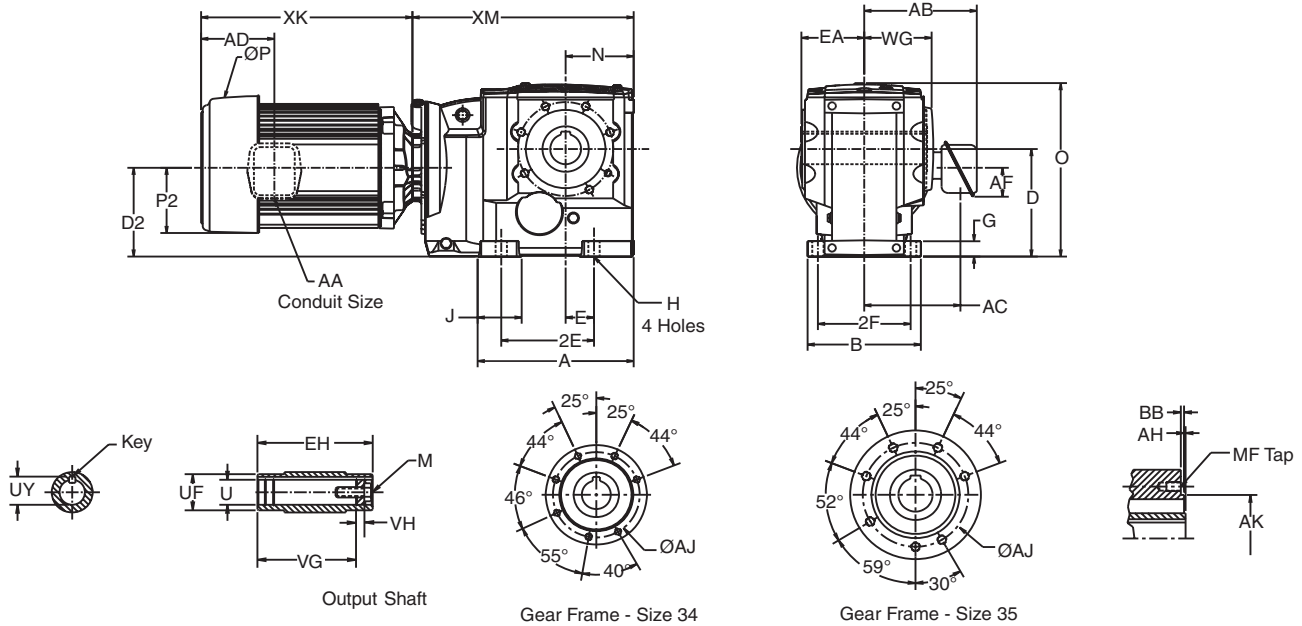

OtN Series

Gear Frame	Version	A	B	D ¹	D2	E	2E	2F	G	H	J	O	N	WG	XM	
															56T-215T	254T-286T
34	S2	10.13	7.87	7.09	5.90	1.57	5.91	6.50	1.07	.71	2.67	12.05	4.49	4.66	14.56	-
35	S2	11.92	8.66	8.35	6.89	2.17	7.09	7.09	1.18	.87	3.45	13.58	5.20	5.15	16.90	17.25

Output Shaft

Gear Frame	Version	EA	EH	U ⁶	UF	UY	VG	VH	Key ⁵	M
34	S2	4.49	8.97	2.000	2.56	2.210	7.44	.79	1/2 X 7/16 X 2 5/8	5/8-11 X 1.75
35	S2	4.83	9.66	2.375	3.54	2.656	8.15	.94	5/8 X 5/8 X 3 5/8	3/4-10 X 2.00

Face Mount

Gear Frame	Version	AH	AJ	AK	BB	MF
34	S2	.14	5.98	5.12	.28	M10 X .87
35	S2	.13	7.48	6.10	.28	M12 X .87

Motor Frame	Motor Type ³	Gear Frame	P	P2	AA	AB	AC	AD	AF	XK
56	T	Any	7.31	3.31	.75	6.10	4.50	3.86	1.77	9.79
143T/145T	T	Any	7.31	3.31	.75	6.10	4.50	3.86	1.77	11.04
145TY	T	Any	7.31	3.31	.75	6.10	4.50	3.86	1.77	12.04
182T/184T	T	Any	9.56	4.34	.75	6.10	4.50	5.13	1.77	14.04
213T	T	Any	11.25	5.06	1.00	8.42	7.17	5.60	2.42	16.15
215T	T	Any	11.25	5.06	1.00	8.42	7.17	5.60	2.42	17.65
254T	T	34	13.38	6.00	1.25	9.79	7.68	8.29	1.81	20.58
	T	35	13.38	6.00	1.25	9.79	7.68	8.29	1.81	19.61
256T	T	34	13.38	6.00	1.25	9.79	7.68	8.29	1.81	22.33
	T	35	13.38	6.00	1.25	9.79	7.68	8.29	1.81	21.36
284T	T	35	13.38	6.00	1.50	10.58	8.18	8.29	2.13	21.86
286T	T	35	13.38	6.00	1.50	10.33	7.93	8.29	2.13	23.36

¹ Dimension "D" will never be exceeded, but may vary from values shown. When exact dimensions are required, shims up to .03" may be necessary.
² All rough casting dimensions may vary by .25" due to casting variations.
³ Motor dimensions for other than "Type T" three phase TEFC motors, refer to pages B-98 - B-99.
⁴ Driven shaft entry can be from either side of the gear reducer housing by reversing positioning of the snap rings and washer illustrated.
⁵ Output key supplied only on frame 34 "S2" version.
⁶ Output bore tolerance: +.0020", - .0000" for all diameters.

3-Stage Finished Bore Hollow Shaft Face Mount - OtN26 - 28

Standard conduit box location will be opposite face mounting unless specified otherwise.

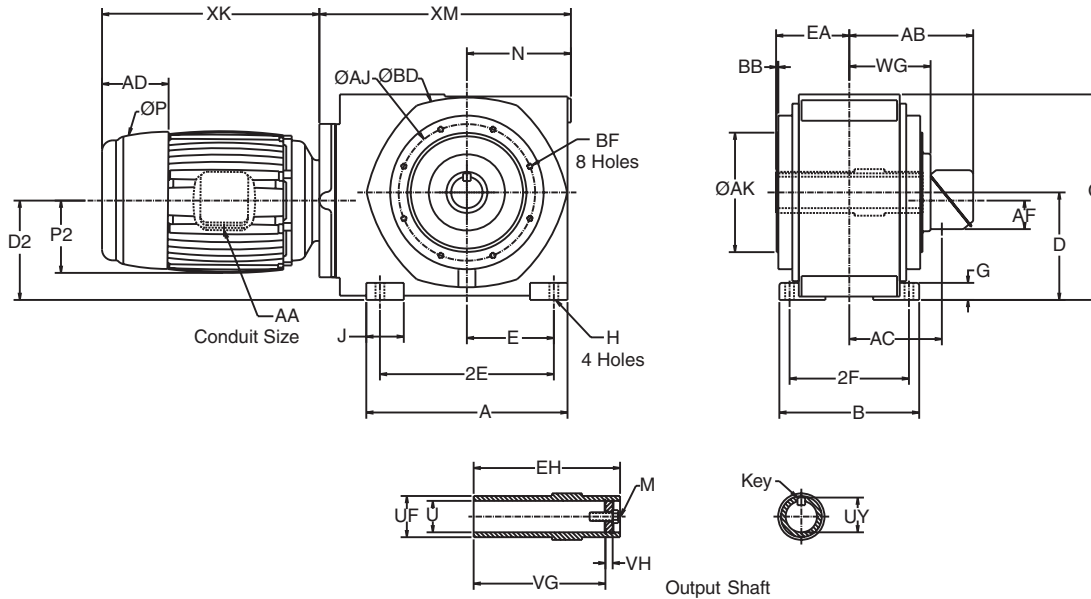

Gear Frame	Version	A	B	D ¹	D2	E	2E	2F	G	H	J	O	N	WG	XM		
															182T-184T	213T-215T	254T-UP
26	S1	16.73	11.42	8.86	8.43	6.99	13.98	9.45	1.57	.87	3.54	16.65	8.74	6.97	23.22	24.22	22.21
27	S1	19.29	12.60	9.84	8.66	8.27	16.54	10.63	1.77	.94	3.94	18.50	10.04	7.72	25.30	26.30	24.30
28	S1	23.23	16.14	12.40	11.42	10.04	20.08	13.78	1.97	1.02	4.33	23.70	12.01	9.49	-	33.04	28.95

Output Shaft

Gear Frame	Version	EA	EH	U ⁵	UF	UY	VG	VH	Key	M
26	S1	6.10	12.20	2.750	3.35	3.027	10.25	.91	5/8 Sq.	3/4-10
27	S1	6.70	13.40	3.125	3.75	3.454	11.40	.91	3/4 Sq.	3/4-10
28	S1	8.45	16.90	3.625	4.35	4.009	14.95	1.02	7/8 Sq.	1-8

Face Mount

Gear Frame	Version	AJ	AK	BB	BD	BF
26	S1	11.81	9.84	.20	13.78	M16 X 22
27	S1	13.78	11.81	.20	15.75	M16 X 22
28	S1	15.75	13.78	.20	17.72	M16 X 22

Motor Frame	Motor Type ³	Gear Frame	P	P2	AA	AB	AC	AD	AF	XK
182T/184T	T	26,27	9.56	4.34	.75	6.10	4.50	5.13	1.77	12.03
213T	T	All	11.25	5.06	1.00	8.42	7.17	5.60	2.42	13.75
215T	T	All	11.25	5.06	1.00	8.42	7.17	5.60	2.42	15.25
254T	T	All	13.38	6.00	1.25	9.79	7.68	8.29	1.81	19.61
256T	T	All	13.38	6.00	1.25	9.79	7.68	8.29	1.81	21.36
284T	T	All	13.38	6.00	1.50	10.58	8.18	8.29	2.13	21.86
286T	T	All	13.38	6.00	1.50	10.33	7.93	8.29	2.13	23.36
324T/326T	T	27,28	17.20	7.78	2.00	14.99	11.34	14.16	3.63	24.96
364T/365T	T	27,28	18.22	9.11	3.00	16.31	12.19	14.37	3.38	26.13

¹ Dimension "D" will never be exceeded, but may vary from values shown. When exact dimensions are required, shims up to .03" may be necessary.

² All rough casting dimensions may vary by .25" due to casting variations.

³ Motor dimensions for other than "Type T" three phase TEFC motors, refer to pages B-98 - B-99.

⁴ Driven shaft entry can be from either side of the gear reducer housing by reversing positioning of the snap rings and washer illustrated.

⁵ Output bore tolerance: +.0020", -.0000" for all diameters.

Combined Finished Bore Hollow Shaft Face Mount - OtN32 - 33

Standard conduit box location will be opposite face mounting unless specified otherwise.

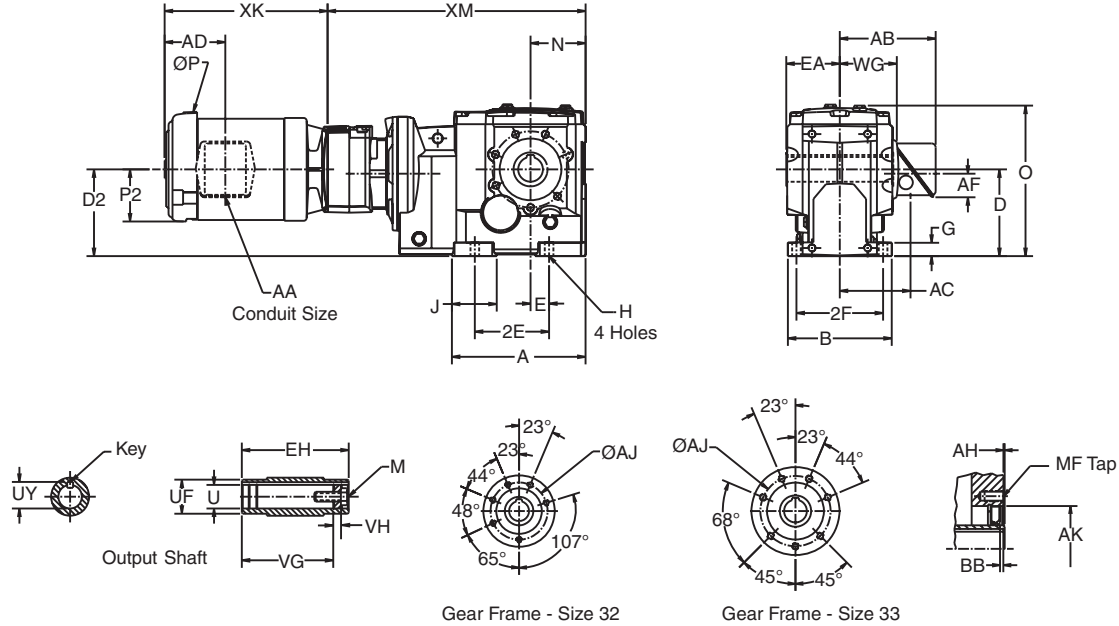

OtN Series

Gear Frame	Version	A	B	D ¹	D2	E	2E	2F	G	H	J	O	N	WG	XM
32	S2	7.81	5.71	4.41	4.06	1.38	5.12	4.71	.73	.43	2.34	8.09	3.03	3.15	14.49
33	S2	8.50	6.61	5.51	4.91	1.18	4.72	5.51	.85	.55	2.86	9.69	3.54	3.63	19.90

Output Shaft

Gear Frame	Version	EA	EH	U ⁵	UF	UY	VG	VH	Key	M
32	S2	2.98	5.96	1.375	1.96	1.523	5.20	.55	5/16 X 5/16 X 1 13/16	1/2-13 X 1.00
33	S2	3.47	6.94	1.500	2.16	1.674	5.96	.55	3/8 X 3/8 X 2 1/4	5/8-11 X 1.75

Face Mount

Gear Frame	Version	AH	AJ	AK	BB	MF
32	S2	.12	3.94	3.15	.16	M10 X .87
33	S2	.12	4.84	3.94	.16	M12 X .87

Motor Frame	Motor Type ³	Gear Frame	P	P2	AA	AB	AC	AD	AF	XK
56	T	32	7.31	3.31	.75	6.10	4.50	3.86	1.77	10.37
	T	33	7.31	3.31	.75	6.10	4.50	3.86	1.77	9.79
143T/145T	T	32	7.31	3.31	.75	6.10	4.50	3.86	1.77	11.62
	T	33	7.31	3.31	.75	6.10	4.50	3.86	1.77	11.04
145TY	T	33	7.31	3.31	.75	6.10	4.50	3.86	1.77	12.04

¹ Dimension "D" will never be exceeded, but may vary from values shown. When exact dimensions are required, shims up to .03" may be necessary.
² All rough casting dimensions may vary by .25" due to casting variations.
³ Motor dimensions for other than "Type T" three phase TEFC motors, refer to pages B-98 - B-99.
⁴ Driven shaft entry can be from either side of the gear reducer housing by reversing positioning of the snap rings and washer illustrated.
⁵ Output bore tolerance: +.0020", - .0000" for all diameters.

Combined Finished Bore Hollow Shaft Face Mount - OtN34 - 35

Standard conduit box location will be opposite face mounting unless specified otherwise.

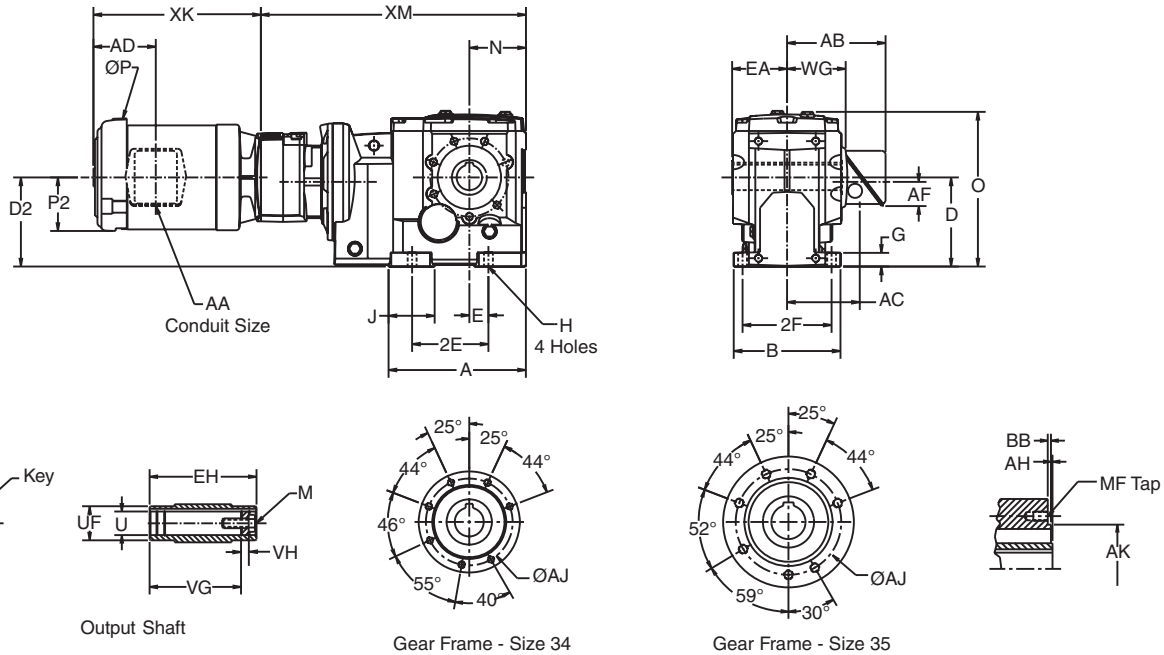

Gear Frame	Version	A	B	D ¹	D2	E	2E	2F	G	H	J	O	N	WG	XM
34	S2	10.13	7.87	7.09	5.57	1.57	5.91	6.50	1.07	.71	2.67	12.05	4.49	4.66	21.55
35	S2	11.92	8.66	8.35	6.56	2.17	7.09	7.09	1.18	.87	3.45	13.58	5.20	5.15	23.87

Output Shaft

Gear Frame	Version	EA	EH	U ⁶	UF	UY	VG	VH	Key ⁵	M
34	S2	4.49	8.97	2.000	2.56	2.210	7.44	.79	1/2 X 7/16 X 2 5/8	5/8-11 X 1.75
35	S2	4.83	9.66	2.375	3.54	2.656	8.15	.94	5/8 X 5/8 X 3 5/8	3/4-10 X 2.00

Face Mount

Gear Frame	Version	AH	AJ	AK	BB	MF
34	S2	.14	5.98	5.12	.28	M10 X .87
35	S2	.13	7.48	6.10	.28	M12 X .87

Motor Frame	Motor Type ³	Gear Frame	P	P2	AA	AB	AC	AD	AF	XK
56	T	Any	7.31	3.31	.75	6.10	4.50	3.86	1.77	9.79
143T/145T	T	Any	7.31	3.31	.75	6.10	4.50	3.86	1.77	11.04
145TY	T	Any	7.31	3.31	.75	6.10	4.50	3.86	1.77	12.04
182T/184T	T	35	9.56	4.34	.75	6.10	4.50	5.13	1.77	14.04

¹ Dimension "D" will never be exceeded, but may vary from values shown. When exact dimensions are required, shims up to .03" may be necessary.

² All rough casting dimensions may vary by .25" due to casting variations.

³ Motor dimensions for other than "Type T" three phase TEFC motors, refer to pages B-98 - B-99.

⁴ Driven shaft entry can be from either side of the gear reducer housing by reversing positioning of the snap rings and washer illustrated.

⁵ Output key supplied only on frame 34 "S2" version.

⁶ Output bore tolerance: +.0020", - .0000" for all diameters.

Combined Finished Bore Hollow Shaft Face Mount - OtN26 - 28

Standard conduit box location will be opposite face mounting unless specified otherwise.

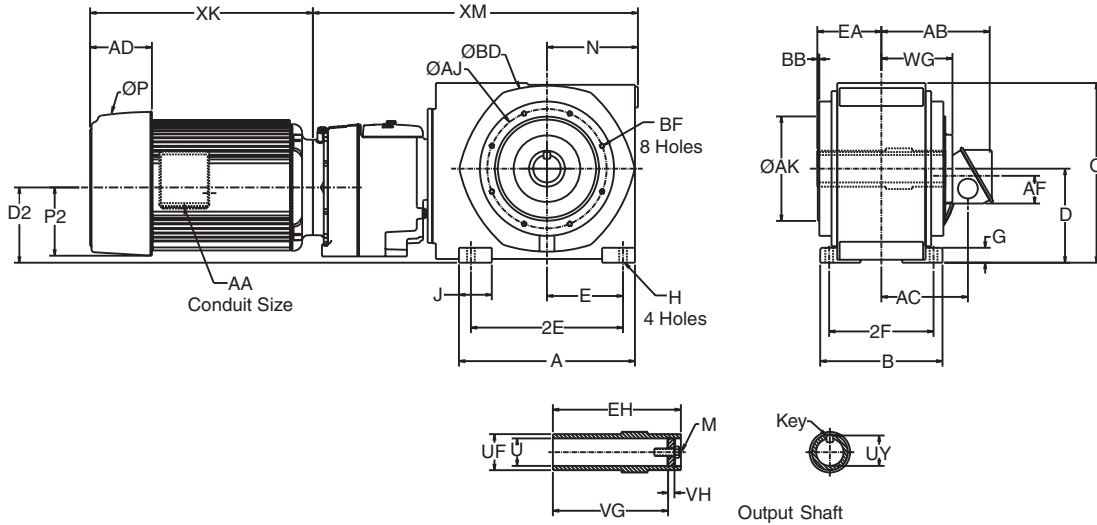

OtN Series

Gear Frame	Version	A	B	D ¹	D2	E	2E	2F	G	H	J	O	N	WG	XM		
															56-184T	213T-215T	254T-UP
26A	S1	16.73	11.42	8.86	7.66	6.99	13.98	9.45	1.57	.87	3.54	16.65	8.74	6.97	30.80	30.80	30.80
27A	S1	19.29	12.60	9.84	7.89	8.27	16.54	10.63	1.77	.94	3.94	18.50	10.04	7.72	31.47	31.47	31.47
28A	S1	23.23	16.14	12.40	10.40	10.04	20.08	13.78	1.97	1.02	4.33	23.70	12.01	9.49	37.14	37.14	37.49

Output Shaft

Gear Frame	Version	EA	EH	U ⁵	UF	UY	VG	VH	Key	M
26A	S1	6.10	12.20	2.750	3.35	3.027	10.25	.91	5/8 Sq.	3/4-10
27A	S1	6.70	13.40	3.125	3.75	3.454	11.40	.91	3/4 Sq.	3/4-10
28A	S1	8.45	16.90	3.625	4.35	4.009	14.95	1.02	7/8 Sq.	1-8

Face Mount

Gear Frame	Version	AJ	AK	BB	BD	BF
26A	S1	11.81	9.84	.20	13.78	M16 X 22
27A	S1	13.78	11.81	.20	15.75	M16 X 22
28A	S1	15.75	13.78	.20	17.72	M16 X 22

Motor Frame	Motor Type ³	Gear Frame	P	P2	AA	AB	AC	AD	AF	XK
56	T	All	7.31	3.31	.75	6.10	4.50	3.86	1.77	9.79
143T/145T	T	All	7.31	3.31	.75	6.10	4.50	3.86	1.77	11.04
145TY	T	All	7.31	3.31	.75	6.10	4.50	3.86	1.77	12.04
182T/184T	T	All	9.56	4.34	.75	6.10	4.50	5.13	1.77	14.04
213T	T	All	11.25	5.06	1.00	8.42	7.17	5.60	2.42	16.15
215T	T	All	11.25	5.06	1.00	8.42	7.17	5.60	2.42	17.65
254T	T	27A,28A	13.38	6.00	1.25	9.79	7.68	8.29	1.81	19.61
256T	T	28A	13.38	6.00	1.25	9.79	7.68	8.29	1.81	21.36
284T	T	28A	13.38	6.00	1.50	10.58	8.18	8.29	2.13	21.86
286T	T	28A	13.38	6.00	1.50	10.33	7.93	8.29	2.13	23.36

¹ Dimension "D" will never be exceeded, but may vary from values shown. When exact dimensions are required, shims up to .03" may be necessary. ⁴ Driven shaft entry can be from either side of the gear reducer housing by reversing positioning of the snap rings and washer illustrated.

² All rough casting dimensions may vary by .25" due to casting variations. ⁵ Output bore tolerance: +.0020", -.0000" for all diameters.

³ Motor dimensions for other than "Type T" three phase TEFC motors, refer to pages B-98 - B-99.

3-Stage Finished Bore Hollow Shaft Flange Mount - OtN32 - 33

Standard conduit box location will be opposite flange unless specified otherwise.

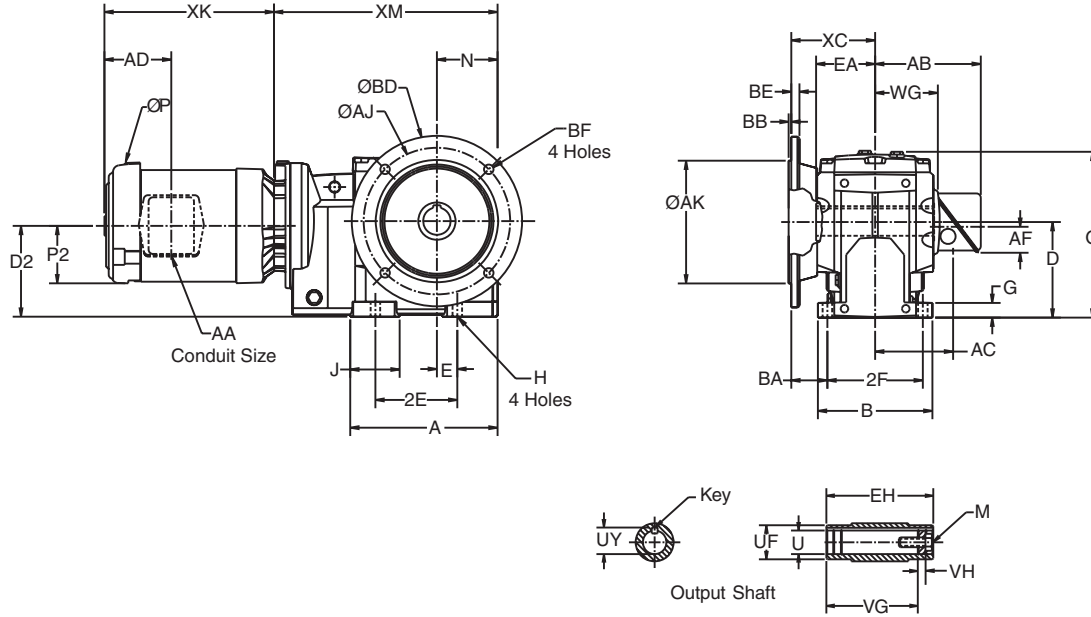

Gear Frame	Version	A	B	D ¹	D2	E	2E	2F	G	H	J	O	N	BA	WG	XC	XM
32	S2	7.81	5.71	4.41	3.78	1.38	5.12	4.71	.73	.43	2.34	8.09	3.03	1.81	3.22	4.04	10.98
33	S2	8.50	6.61	5.51	5.24	1.18	4.72	5.51	.85	.55	2.86	9.69	3.54	2.08	3.73	4.84	12.90

Output Shaft

Gear Frame	Version	EA	EH	U ⁵	UF	UY	VG	VH	Key	M
32	S2	2.98	5.96	1.375	1.96	1.523	5.20	.55	5/16 X 5/16 X 1 13/16	1/2-13 X 1.00
33	S2	3.47	6.94	1.500	2.16	1.674	5.96	.55	3/8 X 3/8 X 2 1/4	5/8-11 X 1.75

Output Flange

Gear Frame	Flange Code	AK	AJ	BB	BD	BE	BF
32	5	5.118	6.50	.14	7.87	.39	.47
	6	7.087	8.46	.16	9.84	.47	.55
33	5	7.087	8.46	.16	9.84	.47	.55
	6	9.055	10.43	.16	11.81	.47	.55

Motor Frame	Motor Type ³	Gear Frame	P	P2	AA	AB	AC	AD	AF	XK
56	T	Any	7.31	3.31	.75	6.10	4.50	3.86	1.77	9.79
143T/145T	T	Any	7.31	3.31	.75	6.10	4.50	3.86	1.77	11.04
145TY	T	Any	7.31	3.31	.75	6.10	4.50	3.86	1.77	12.04
182T/184T	T	Any	9.56	4.34	.75	6.10	4.50	5.13	1.77	14.04
213T	T	33	11.25	5.06	1.00	8.42	7.17	5.60	2.42	16.15
215T	T	33	11.25	5.06	1.00	8.42	7.17	5.60	2.42	17.65

¹ Dimension "D" will never be exceeded, but may vary from values shown. When exact dimensions are required, shims up to .03" may be necessary.

² All rough casting dimensions may vary by .25" due to casting variations.

³ Motor dimensions for other than "Type T" three phase TEFC motors, refer to pages B-98 - B-99.

⁴ Driven shaft entry can be from either side of the gear reducer housing by reversing positioning of the snap rings and washer illustrated.

⁵ Output bore tolerance: +.0020", -.0000" for all diameters.

3-Stage Finished Bore Hollow Shaft Flange Mount - OtN34 - 35

Standard conduit box location will be opposite flange unless specified otherwise.

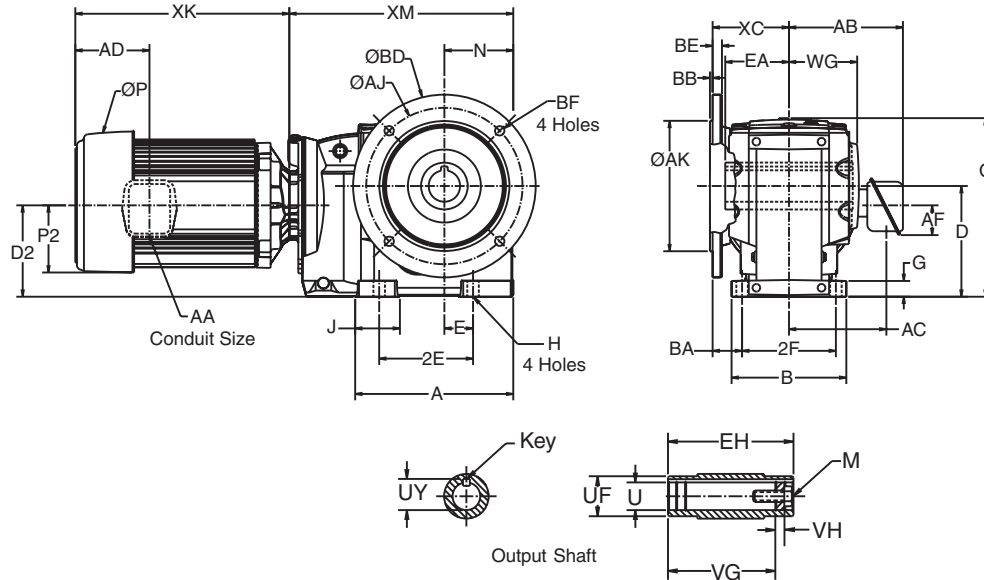

OtN Series

Gear Frame	Version	A	B	D ¹	D ₂	E	2E	2F	G	H	J	O	N	BA	WG	XC	XM	
																	56T-215T	254T-286T
34	S2	10.13	7.87	7.09	5.90	1.57	5.91	6.50	1.07	.71	2.67	12.05	4.49	1.93	4.66	5.18	14.56	-
35	S2	11.92	8.66	8.35	6.89	2.17	7.09	7.09	1.18	.87	3.45	13.58	5.20	2.22	5.15	5.76	16.90	17.25

Output Shaft

Gear Frame	Version	EA	EH	U ⁶	UF	UY	VG	VH	Key ⁵	M
34	S2	4.49	8.97	2.000	2.56	2.210	7.44	.79	1/2 X 7/16 X 2 5/8	5/8-11 X 1.75
35	S2	4.83	9.66	2.375	3.54	2.656	8.15	.94	5/8 X 5/8 X 3 5/8	3/4-10 X 2.00

Output Flange

Gear Frame	Flange Code	AK	AJ	BB	BD	BE	BF
34	5	9.055	10.43	.16	11.80	.59	.55
	6	9.842	11.80	.16	13.77	.59	.71
35	5	9.842	11.80	.20	13.77	.71	.71
	6	11.810	13.77	.20	15.75	.71	.71

Motor Frame	Motor Type ³	Gear Frame	P	P ₂	AA	AB	AC	AD	AF	XK
56	T	Any	7.31	3.31	.75	6.10	4.50	3.86	1.77	9.79
143T/145T	T	Any	7.31	3.31	.75	6.10	4.50	3.86	1.77	11.04
145TY	T	Any	7.31	3.31	.75	6.10	4.50	3.86	1.77	12.04
182T/184T	T	Any	9.56	4.34	.75	6.10	4.50	5.13	1.77	14.04
213T	T	Any	11.25	5.06	1.00	8.42	7.17	5.60	2.42	16.15
215T	T	Any	11.25	5.06	1.00	8.42	7.17	5.60	2.42	17.65
254T	T	34	13.38	6.00	1.25	9.79	7.68	8.29	1.81	20.58
	T	35	13.38	6.00	1.25	9.79	7.68	8.29	1.81	19.61
256T	T	34	13.38	6.00	1.25	9.79	7.68	8.29	1.81	22.33
	T	35	13.38	6.00	1.25	9.79	7.68	8.29	1.81	21.36
284T	T	35	13.38	6.00	1.50	10.58	8.18	8.29	2.13	21.86
286T	T	35	13.38	6.00	1.50	10.33	7.93	8.29	2.13	23.36

¹ Dimension "D" will never be exceeded, but may vary from values shown. When exact dimensions are required, shims up to .03" may be necessary. ⁴ Driven shaft entry can be from either side of the gear reducer housing by reversing positioning of the snap rings and washer illustrated.

² All rough casting dimensions may vary by .25" due to casting variations. ⁵ Output key supplied only on frame 34 "S2" version.

³ Motor dimensions for other than "Type T" three phase TEFC motors, refer to pages B-98 - B-99. ⁶ Output bore tolerance: +.0020", -.0000" for all diameters.

3-Stage Finished Bore Hollow Shaft Flange Mount - OtN26 - 28

Standard conduit box location will be opposite flange unless specified otherwise.

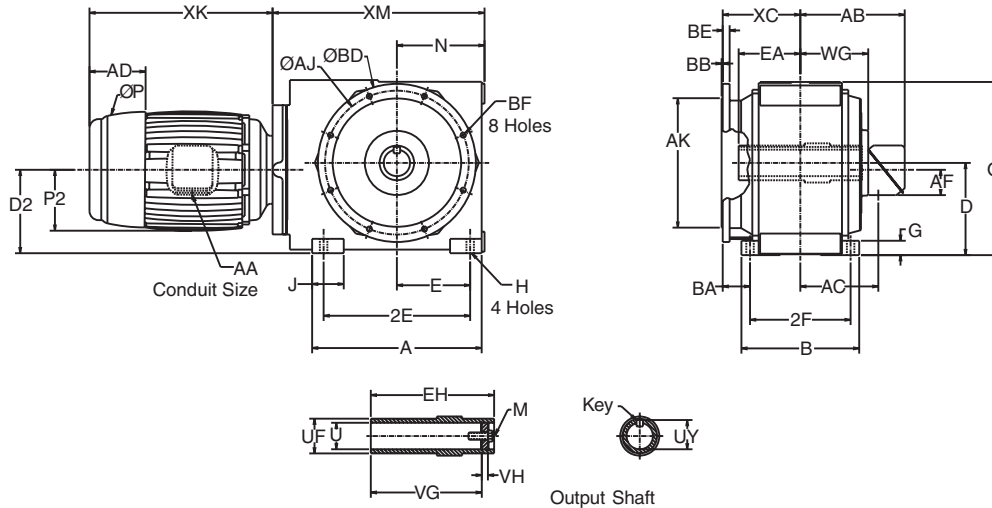

Gear Frame	Version	A	B	D ¹	D ₂	E	2E	2F	G	H	J	O	N	BA	XC	WG	XM		
																	182T-184T	213T-215T	254T -Up
26	S1	16.73	11.42	8.86	8.43	6.99	13.98	9.45	1.57	.87	3.54	16.65	8.74	3.54	9.00	6.97	23.22	24.22	22.21
27	S1	19.29	12.60	9.84	8.66	8.27	16.54	10.63	1.77	.94	3.94	18.50	10.04	3.54	8.55	7.72	25.30	26.30	24.30
28	S1	23.23	16.14	12.40	11.42	10.04	20.08	13.78	1.97	1.02	4.33	23.70	12.01	3.74	11.51	9.49	-	33.04	28.95

Output Shaft

Gear Frame	Version	EA	EH	U ⁵	UF	UY	VG	VH	Key	M
26	S1	6.10	12.20	2.750	3.35	3.027	10.25	.91	5/8 Sq.	3/4-10
27	S1	6.70	13.40	3.125	3.75	3.454	11.40	.91	3/4 Sq.	3/4-10
28	S1	8.45	16.90	3.625	4.35	4.009	14.95	1.02	7/8 Sq.	1-8

Output Flange

Gear Frame	Flange Code	AJ	AK	BB	BD	BE	BF
26	5	15.75	13.75	.20	17.72	.79	.71
27	5	15.75	13.78	.20	17.72	.79	.71
28	5	19.69	17.72	.24	21.65	.94	.71

Motor Frame	Motor Type ³	Gear Frame	P	P ₂	AA	AB	AC	AD	AF	XK
182T/184T	T	26,27	9.56	4.34	.75	6.10	4.50	5.13	1.77	12.03
213T	T	All	11.25	5.06	1.00	8.42	7.17	5.60	2.42	13.75
215T	T	All	11.25	5.06	1.00	8.42	7.17	5.60	2.42	15.25
254T	T	All	13.38	6.00	1.25	9.79	7.68	8.29	1.81	19.61
256T	T	All	13.38	6.00	1.25	9.79	7.68	8.29	1.81	21.36
284T	T	All	13.38	6.00	1.50	10.58	8.18	8.29	2.13	21.86
286T	T	All	13.38	6.00	1.50	10.33	7.93	8.29	2.13	23.36
324T/326T	T	27,28	17.20	7.78	2.00	14.99	11.34	14.16	3.63	24.96
364T/365T	T	27,28	18.22	9.11	3.00	16.31	12.19	14.37	3.38	26.13

¹ Dimension "D" will never be exceeded, but may vary from values shown. When exact dimensions are required, shims up to .03" may be necessary.
² All rough casting dimensions may vary by .25" due to casting variations.
³ Motor dimensions for other than "Type T" three phase TEFC motors, refer to pages B-98 - B-99.
⁴ Driven shaft entry can be from either side of the gear reducer housing by reversing positioning of the snap rings and washer illustrated.
⁵ Output bore tolerance: +.0020", - .0000" for all diameters.

Combined Finished Bore Hollow Shaft Flange Mount - OtN32 - 33

Standard conduit box location will be opposite flange unless specified otherwise.

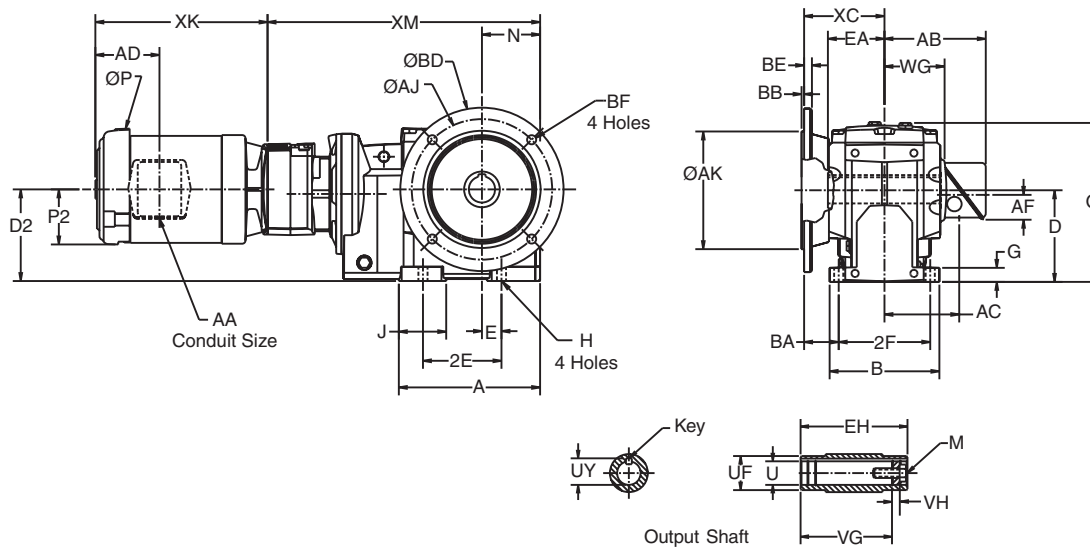

OtN Series

Gear Frame	Version	A	B	D'	D2	E	2E	2F	G	H	J	O	N	BA	WG	XC	XM
32	S2	7.81	5.71	4.41	4.06	1.38	5.12	4.71	.73	.43	2.34	8.09	3.03	1.81	3.22	4.04	14.49
33	S2	8.50	6.61	5.51	4.91	1.18	4.72	5.51	.85	.55	2.86	9.69	3.54	2.08	3.73	4.84	19.90

Output Shaft

Gear Frame	Version	EA	EH	U ⁵	UF	UY	VG	VH	Key	M
32	S2	2.98	5.96	1.375	1.96	1.523	5.20	.55	5/16 X 5/16 X 1 13/16	1/2-13 X 1.00
33	S2	3.47	6.94	1.500	2.16	1.674	5.96	.55	3/8 X 3/8 X 2 1/4	5/8-11 X 1.75

Output Flange

Gear Frame	Flange Code	AK	AJ	BB	BD	BE	BF
32	5	5.118	6.50	.14	7.87	.39	.47
	6	7.087	8.46	.16	9.84	.47	.55
33	5	7.087	8.46	.16	9.84	.47	.55
	6	9.055	10.43	.16	11.81	.47	.55

Motor Frame	Motor Type ³	Gear Frame	P	P2	AA	AB	AC	AD	AF	XK
56	T	32	7.31	3.31	.75	6.10	4.50	3.86	1.77	10.37
	T	33	7.31	3.31	.75	6.10	4.50	3.86	1.77	9.79
143T/145T	T	32	7.31	3.31	.75	6.10	4.50	3.86	1.77	11.62
	T	33	7.31	3.31	.75	6.10	4.50	3.86	1.77	11.04
145TY	T	33	7.31	3.31	.75	6.10	4.50	3.86	1.77	12.04

¹ Dimension "D" will never be exceeded, but may vary from values shown. When exact dimensions are required, shims up to .03" may be necessary.

² All rough casting dimensions may vary by .25" due to casting variations.

³ Motor dimensions for other than "Type T" three phase TEFC motors, refer to pages B-98 - B-99.

⁴ Driven shaft entry can be from either side of the gear reducer housing by reversing positioning of the snap rings and washer illustrated.

⁵ Output bore tolerance: +.0020", -.0000" for all diameters.

Combined Finished Bore Hollow Shaft Flange Mount - OtN34 - 35

Standard conduit box location will be opposite flange unless specified otherwise.

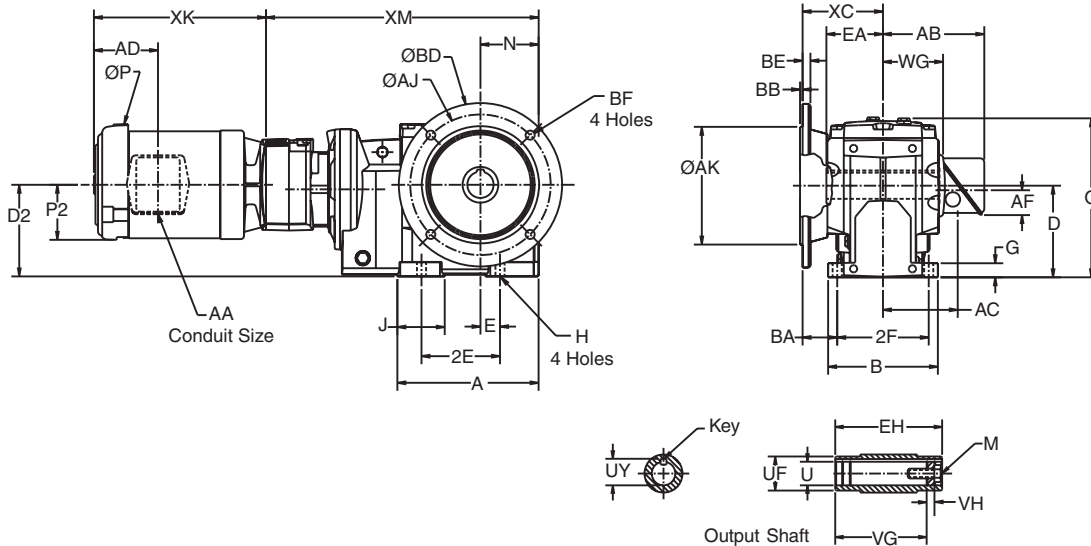

Gear Frame	Version	A	B	D ¹	D2	E	2E	2F	G	H	J	O	N	BA	WG	XC	XM
34	S2	10.13	7.87	7.09	5.57	1.57	5.91	6.50	1.07	.71	2.67	12.05	4.49	1.93	4.66	5.18	21.55
35	S2	11.92	8.66	8.35	6.56	2.17	7.09	7.09	1.18	.87	3.45	13.58	5.20	2.22	5.15	5.76	23.87

Output Shaft

Gear Frame	Version	EA	EH	U ⁶	UF	UY	VG	VH	Key ⁵	M
34	S2	4.49	8.97	2.000	2.56	2.210	7.44	.79	1/2 X 7/16 X 2 5/8	5/8-11 X 1.75
35	S2	4.83	9.66	2.375	3.54	2.656	8.15	.94	5/8 X 5/8 X 3 5/8	3/4-10 X 2.00

Output Flange

Gear Frame	Flange Code	AK	AJ	BB	BD	BE	BF
34	5	9.055	10.43	.16	11.80	.59	.55
	6	9.842	11.80	.16	13.77	.59	.71
35	5	9.842	11.80	.20	13.77	.71	.71
	6	11.810	13.77	.20	15.75	.71	.71

Motor Frame	Motor Type ³	Gear Frame	P	P2	AA	AB	AC	AD	AF	XK
56	T	Any	7.31	3.31	.75	6.10	4.50	3.86	1.77	9.79
143T/145T	T	Any	7.31	3.31	.75	6.10	4.50	3.86	1.77	11.04
145TY	T	Any	7.31	3.31	.75	6.10	4.50	3.86	1.77	12.04
182T/184T	T	35	9.56	4.34	.75	6.10	4.50	5.13	1.77	14.04

¹ Dimension "D" will never be exceeded, but may vary from values shown. When exact dimensions are required, shims up to .03" may be necessary.

² All rough casting dimensions may vary by .25" due to casting variations.

³ Motor dimensions for other than "Type T" three phase TEFC motors, refer to pages B-98 - B-99.

⁴ Driven shaft entry can be from either side of the gear reducer housing by reversing positioning of the snap rings and washer illustrated.

⁵ Output key supplied only on frame 34 "S2" version.

⁶ Output bore tolerance: +.0020", -.0000" for all diameters.

Combined Finished Bore Hollow Shaft Flange Mount - OtN26 - 28

Standard conduit box location will be opposite flange unless specified otherwise.

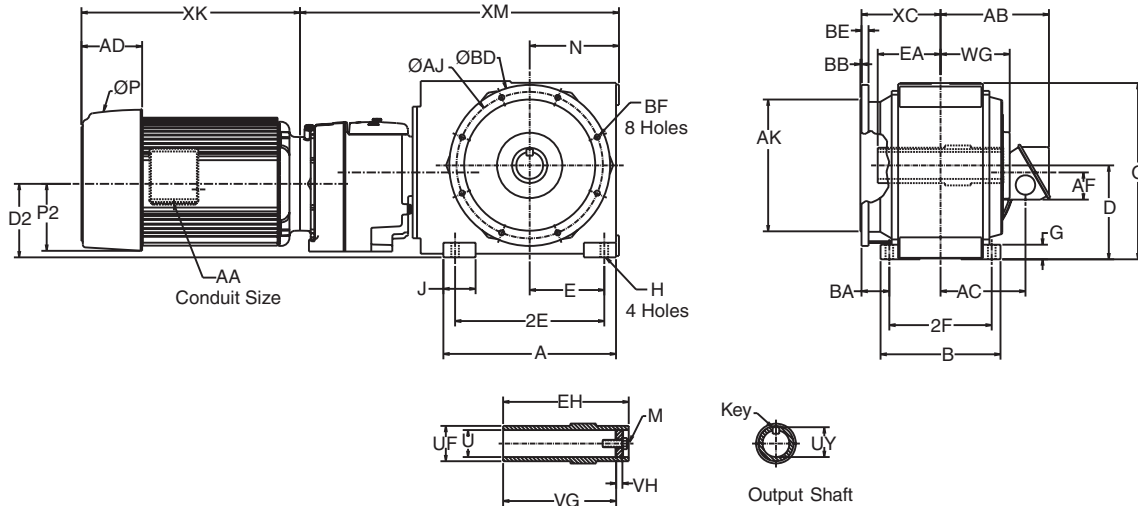

OtN Series

Gear Frame	Version	A	B	D ¹	D2	E	2E	2F	G	H	J	O	N	BA	WG	XC	XM		
																	56-184T	213T-215T	254T -Up
26A	S1	16.73	11.42	8.86	7.66	6.99	13.98	9.45	1.57	.87	3.54	16.65	8.74	3.54	6.97	9.00	30.80	30.80	30.80
27A	S1	19.29	12.60	9.84	7.89	8.27	16.54	10.63	1.77	.94	3.94	18.50	10.04	3.54	7.72	8.55	31.47	31.47	31.47
28A	S1	23.23	16.14	12.40	10.40	10.04	20.08	13.78	1.97	1.02	4.33	23.70	12.01	3.74	9.49	11.51	37.14	37.14	37.49

Output Shaft

Gear Frame	Version	EA	EH	U ⁵	UF	UY	VG	VH	Key	M
26A	S1	6.10	12.20	2.750	3.35	3.027	10.25	.91	5/8 Sq.	3/4-10
27A	S1	6.70	13.40	3.125	3.75	3.454	11.40	.91	3/4 Sq.	3/4-10
28A	S1	8.45	16.90	3.625	4.35	4.009	14.95	1.02	7/8 Sq.	1-8

Output Flange

Gear Frame	Flange Code	AJ	AK	BB	BD	BE	BF
26A	5	15.75	13.75	.20	17.72	.79	.71
27A	5	15.75	13.78	.20	17.72	.79	.71
28A	5	19.69	17.72	.24	21.65	.94	.71

Motor Frame	Motor Type ³	Gear Frame	P	P2	AA	AB	AC	AD	AF	XK
56	T	All	7.31	3.31	.75	6.10	4.50	3.86	1.77	9.79
143T/145T	T	All	7.31	3.31	.75	6.10	4.50	3.86	1.77	11.04
145TY	T	All	7.31	3.31	.75	6.10	4.50	3.86	1.77	12.04
182T/184T	T	All	9.56	4.34	.75	6.10	4.50	5.13	1.77	14.04
213T	T	All	11.25	5.06	1.00	8.42	7.17	5.60	2.42	16.15
215T	T	All	11.25	5.06	1.00	8.42	7.17	5.60	2.42	17.65
254T	T	27A,28A	13.38	6.00	1.25	9.79	7.68	8.29	1.81	19.61
256T	T	28A	13.38	6.00	1.25	9.79	7.68	8.29	1.81	21.36
284T	T	28A	13.38	6.00	1.50	10.58	8.18	8.29	2.13	21.86
286T	T	28A	13.38	6.00	1.50	10.33	7.93	8.29	2.13	23.36

¹ Dimension "D" will never be exceeded, but may vary from values shown. When exact dimensions are required, shims up to .03" may be necessary.
² All rough casting dimensions may vary by .25" due to casting variations.
³ Motor dimensions for other than "Type T" three phase TEFC motors, refer to pages B-98 - B-99.
⁴ Driven shaft entry can be from either side of the gear reducer housing by reversing positioning of the snap rings and washer illustrated.
⁵ Output bore tolerance: +.0020", -.0000" for all diameters.

3-Stage Taper Bushed Shaft Mount OtN32 - 33

Standard conduit box location will be F1 unless specified otherwise.

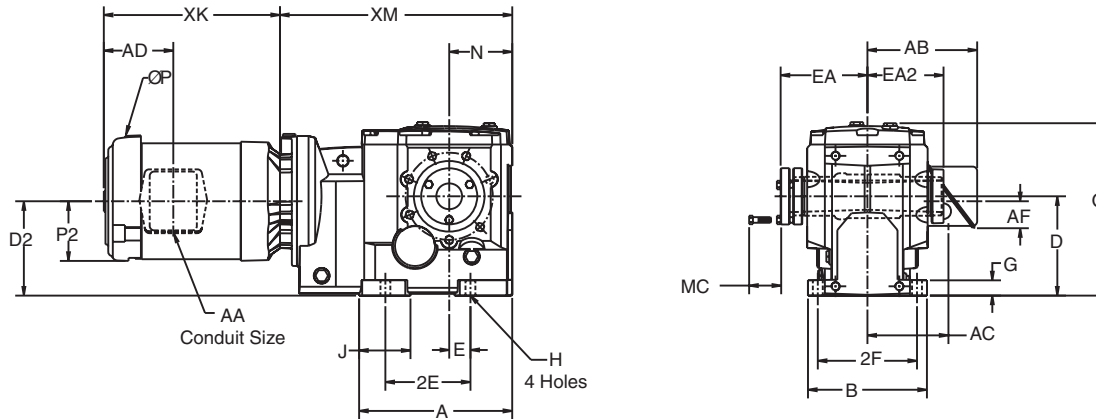

Gear Frame	Version	A	B	D'	D2	E	2E	2F	G	H	J	O	N	XM
32	S2	7.81	5.71	4.41	3.78	1.38	5.12	4.71	.73	.43	2.34	8.09	3.03	10.98
33	S2	8.50	6.61	5.51	5.24	1.18	4.72	5.51	.85	.55	2.86	9.69	3.54	12.90

Output Shaft

Gear Frame	Version	EA	EA2	MC ⁵	Bushing Bores ⁴	
					Min.	Max.
32	S2	4.85	4.27	1.75	3/4	1 7/16
33	S2	4.82	4.23	1.75	3/4	1 7/16

Motor Frame	Motor Type ³	Gear Frame	P	P2	AA	AB	AC	AD	AF	XK
56	T	Any	7.31	3.31	.75	6.10	4.50	3.86	1.77	9.79
143T/145T	T	Any	7.31	3.31	.75	6.10	4.50	3.86	1.77	11.04
145TY	T	Any	7.31	3.31	.75	6.10	4.50	3.86	1.77	12.04
182T/184T	T	Any	9.56	4.34	.75	6.10	4.50	5.13	1.77	14.04
213T	T	33	11.25	5.06	1.00	8.42	7.17	5.60	2.42	16.15
215T	T	33	11.25	5.06	1.00	8.42	7.17	5.60	2.42	17.65

¹ Dimension "D" will never be exceeded, but may vary from values shown. When exact dimensions are required, shims up to .03" may be necessary.

² All rough casting dimensions may vary by .25" due to casting variations.

³ Motor dimensions for other than "Type T" three phase TEFC motors, refer to pages B-98 - B-99.

⁴ Refer to page B-24 by gear frame for listing of all inch and metric bushing bore sizes available.

⁵ The "MC" dimension shows spacing required to install or remove the bushing from the reducer.

⁶ Bushing and dust cap can be installed opposite of how they are shown above.

⁷ Driven shaft entry can be from either side of the gear reducer housing. Refer to Installation Manual for requirements.

⁸ For details of the torque arm kit, refer to page B-22.

3-Stage Taper Bushed Shaft Mount OtN34 - 35

Standard conduit box location will be F1 unless specified otherwise.

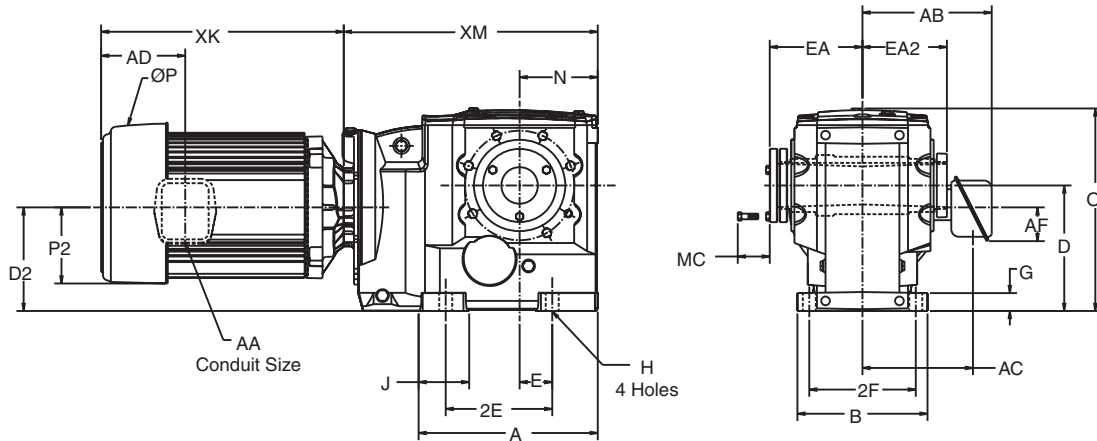

Gear Frame	Version	A	B	D ¹	D2	E	2E	2F	G	H	J	O	N	XM	
														56-215T	254T-286T
34	S2	10.13	7.87	7.09	5.90	1.57	5.91	6.50	1.07	.71	2.67	12.05	4.49	14.56	-
35	S2	11.92	8.66	8.35	6.89	2.17	7.09	7.09	1.18	.87	3.45	13.58	5.20	16.90	17.25

Output Shaft

Gear Frame	Version	EA	EA2	MC ⁵	Bushing Bores ⁴	
					Min.	Max.
34	S2	5.84	5.27	1.88	15/16	1 15/16
35	S2	6.17	5.62	1.88	1 3/8	2 7/16

Motor Frame	Motor Type ³	Gear Frame	P	P2	AA	AB	AC	AD	AF	XK
56	T	Any	7.31	3.31	.75	6.10	4.50	3.86	1.77	9.79
143T/145T	T	Any	7.31	3.31	.75	6.10	4.50	3.86	1.77	11.04
145TY	T	Any	7.31	3.31	.75	6.10	4.50	3.86	1.77	12.04
182T/184T	T	Any	9.56	4.34	.75	6.10	4.50	5.13	1.77	14.04
213T	T	Any	11.25	5.06	1.00	8.42	7.17	5.60	2.42	16.15
215T	T	Any	11.25	5.06	1.00	8.42	7.17	5.60	2.42	17.65
254T	T	34	13.38	6.00	1.25	9.79	7.68	8.29	1.81	20.58
	T	35	13.38	6.00	1.25	9.79	7.68	8.29	1.81	19.61
256T	T	34	13.38	6.00	1.25	9.79	7.68	8.29	1.81	22.33
	T	35	13.38	6.00	1.25	9.79	7.68	8.29	1.81	21.36
284T	T	35	13.38	6.00	1.50	10.58	8.18	8.29	2.13	21.86
286T	T	35	13.38	6.00	1.50	10.33	7.93	8.29	2.13	23.36

¹ Dimension "D" will never be exceeded, but may vary from values shown. When exact dimensions are required, shims up to .03" may be necessary.
² All rough casting dimensions may vary by .25" due to casting variations.
³ Motor dimensions for other than "Type T" three phase TEFC motors, refer to pages B-98 - B-99.
⁴ Refer to page B-24 by gear frame for listing of all inch and metric bushing bore sizes available.

⁵ The "MC" dimension shows spacing required to install or remove the bushing from the reducer.
⁶ Bushing and dust cap can be installed opposite of how they are shown above.
⁷ Driven shaft entry can be from either side of the gear reducer housing. Refer to Installation Manual for requirements.
⁸ For details of the torque arm kit, refer to page B-22.

Combined Taper Bushed Shaft Mount OtN32 - 33

Standard conduit box location will be F1 unless specified otherwise.

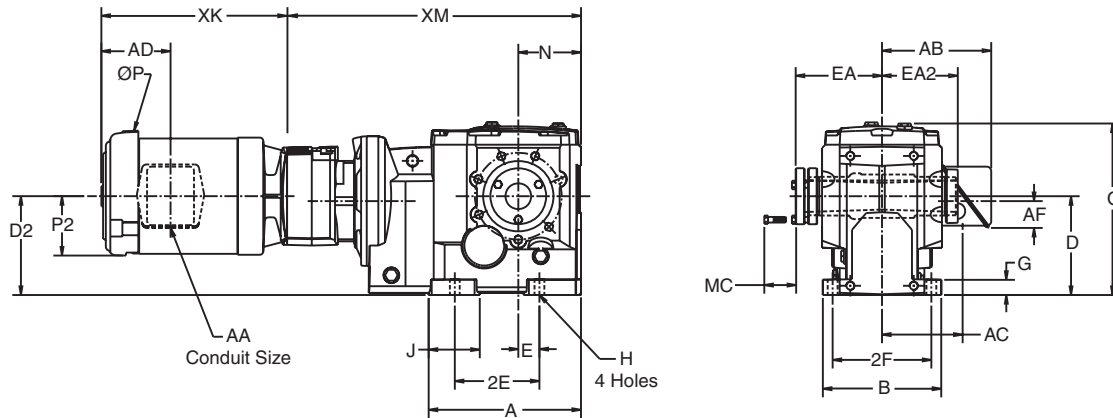

Gear Frame	Version	A	B	D ¹	D ₂	E	2E	2F	G	H	J	O	N	XM
32	S2	7.81	5.71	4.41	4.06	1.38	5.12	4.71	.73	.43	2.34	8.09	3.03	14.49
33	S2	8.50	6.61	5.51	4.91	1.18	4.72	5.51	.85	.55	2.86	9.69	3.54	19.90

Output Shaft

Gear Frame	Version	EA	EA ₂	MC ⁵	Bushing Bores ⁴	
					Min.	Max.
32	S2	4.85	4.27	1.75	3/4	1 7/16
33	S2	4.82	4.23	1.75	3/4	1 7/16

Motor Frame	Motor Type ³	Gear Frame	P	P ₂	AA	AB	AC	AD	AF	XK
56	T	32	7.31	3.31	.75	6.10	4.50	3.86	1.77	10.37
	T	33	7.31	3.31	.75	6.10	4.50	3.86	1.77	9.79
143T/145T	T	32	7.31	3.31	.75	6.10	4.50	3.86	1.77	11.62
	T	33	7.31	3.31	.75	6.10	4.50	3.86	1.77	11.04
145TY	T	33	7.31	3.31	.75	6.10	4.50	3.86	1.77	12.04

¹ Dimension "D" will never be exceeded, but may vary from values shown. When exact dimensions are required, shims up to .03" may be necessary.

² All rough casting dimensions may vary by .25" due to casting variations.

³ Motor dimensions for other than "Type T" three phase TEFC motors, refer to pages B-98 - B-99.

⁴ Refer to page B-24 by gear frame for listing of all inch and metric bushing bore sizes available.

⁵ The "MC" dimension shows spacing required to install or remove the bushing from the reducer.

⁶ Bushing and dust cap can be installed opposite of how they are shown above.

⁷ Driven shaft entry can be from either side of the gear reducer housing. Refer to Installation Manual for requirements.

⁸ For details of the torque arm kit, refer to page B-22.

Combined Taper Bushed Shaft Mount OtN34 - 35

Standard conduit box location will be F1 unless specified otherwise.

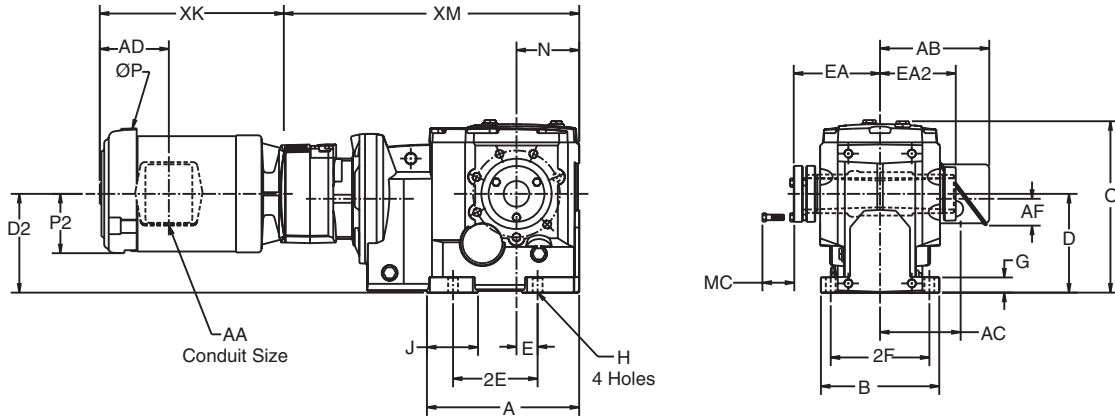

Gear Frame	Version	A	B	D ¹	D2	E	2E	2F	G	H	J	O	N	XM
34	S2	10.13	7.87	7.09	5.57	1.57	5.91	6.50	1.07	.71	2.67	12.05	4.49	21.55
35	S2	11.92	8.66	8.35	6.56	2.17	7.09	7.09	1.18	.87	3.45	13.58	5.20	23.87

Output Shaft

Gear Frame	Version	EA	EA2	MC ⁵	Bushing Bores ⁴	
					Min.	Max.
34	S2	5.84	5.27	1.88	15/16	1 15/16
35	S2	6.17	5.62	1.88	1 3/8	2 7/16

Motor Frame	Motor Type ³	Gear Frame	P	P2	AA	AB	AC	AD	AF	XK
56	T	Any	7.31	3.31	.75	6.10	4.50	3.86	1.77	9.79
143T/145T	T	Any	7.31	3.31	.75	6.10	4.50	3.86	1.77	11.04
145TY	T	Any	7.31	3.31	.75	6.10	4.50	3.86	1.77	12.04
182T/184T	T	35	9.56	4.34	.75	6.10	4.50	5.13	1.77	14.04

¹ Dimension "D" will never be exceeded, but may vary from values shown. When exact dimensions are required, shims up to .03" may be necessary.
² All rough casting dimensions may vary by .25" due to casting variations.
³ Motor dimensions for other than "Type T" three phase TEFC motors, refer to pages B-98 - B-99.
⁴ Refer to page B-24 by gear frame for listing of all inch and metric bushing bore sizes available.

⁵ The "MC" dimension shows spacing required to install or remove the bushing from the reducer.
⁶ Bushing and dust cap can be installed opposite of how they are shown above.
⁷ Driven shaft entry can be from either side of the gear reducer housing. Refer to Installation Manual for requirements.
⁸ For details of the torque arm kit, refer to page B-22.

Alternate Motor Dimensions

Single Phase

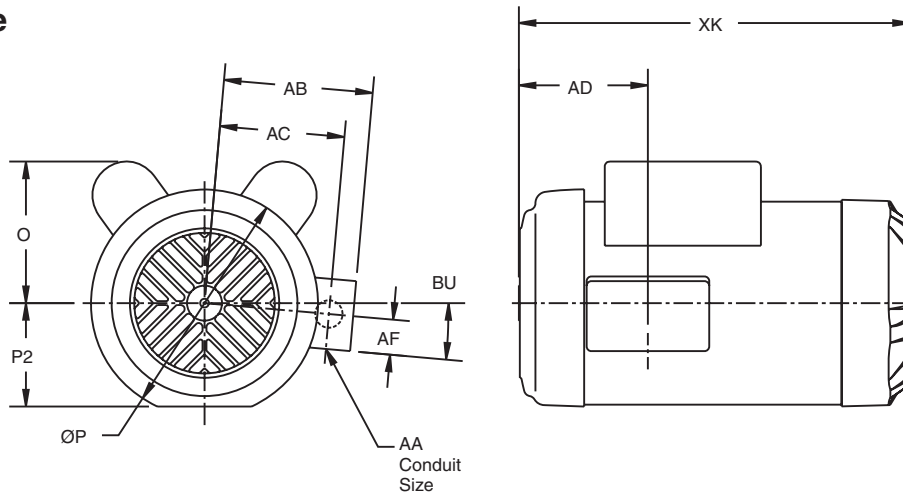

Motor Frame	HP	O	P	P2	AA	AB	AC	AD	AF	BU	XK
48	1/6, 1/4	4.40	6.72	2.79	1/2	4.34	3.55	5.29	1.16	12°	11.88
	1/3, 1/2	4.40	6.72	2.79	1/2	4.72	3.79	5.29	1.13	N/A	11.88
	3/4, 1	3.87	6.72	2.79	1/2	4.34	3.55	5.29	1.16	10°	12.88
56	1/3, 1/2	4.78	7.28	3.31	3/4	4.78	4.00	4.14	1.13	N/A	9.52 ²
	3/4	4.78	7.28	3.31	3/4	4.78	4.00	4.14	1.13	N/A	11.02 ²
143T	1	5.09	7.28	3.31	3/4	4.78	4.00	4.14	1.13	N/A	11.02 ²
145TY	1 1/2, 2	4.53	7.28	3.31	3/4	4.78	3.83	4.14	1.13	5°	12.52
184T	3, 5	5.11	9.56	4.39	3/4	8.58	6.45	7.14	3.09	N/A	16.54

CorroDuty

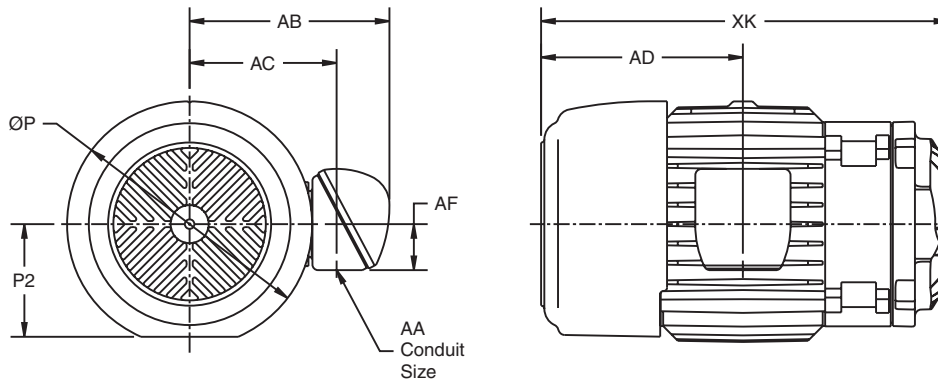

Motor Frame	P	P2	AA	AB	AC	AD	AF	XK
56	7.41	3.44	3/4	6.50	4.59	3.72	1.25	10.21 ²
143T, 145T	7.41	3.44	3/4	6.50	4.59	3.72	1.25	11.21 ²
145TY	7.41	3.44	3/4	6.50	4.59	3.72	1.25	12.71
182T, 184T	9.50	4.56	3/4	7.74	5.69	7.81	1.78	15.77
213T, 215T	11.00	5.44	1	9.47	7.15	9.63	2.00	19.67
254T, 256T	13.31	6.58	1 1/2	11.33	8.51	12.44	2.63	24.26 ¹
284T, 286T	14.62	7.29	1 1/2	11.98	9.16	13.19	2.63	24.71

¹ XK = 23.29 on OtN 34 three stage and 27A combined.

² XK will increase by .58" if used on 32 combined.

Alternate Motor Dimensions

Explosion Proof

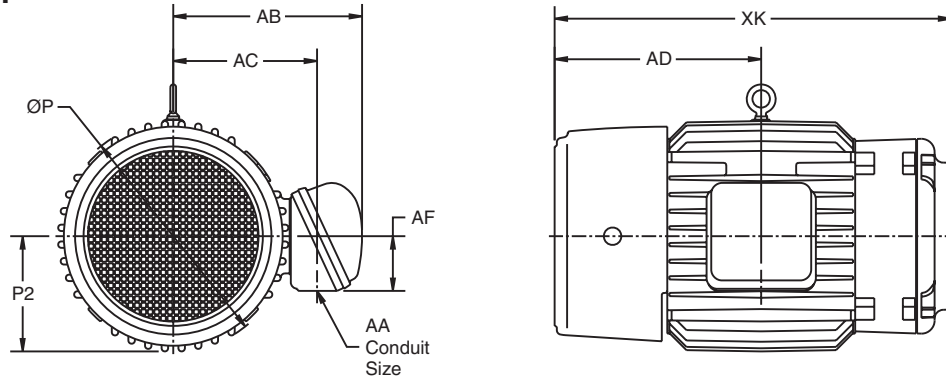

Motor Frame	P	P2	AA	AB	AC	AD	AF	XK
56	7.88	3.38	3/4	6.79	5.31	4.37	1.78	13.15 ²
143T, 145T	7.88	3.38	3/4	6.79	5.31	4.37	1.78	13.90 ²
182T, 184T	9.50	4.56	3/4	7.70	5.79	7.75	2.25	15.70
213T, 215T	11.12	5.44	1	9.06	6.81	8.68	2.63	18.72
254T, 256T	13.36	6.58	1 1/2	10.80	8.22	11.81	3.13	23.65 ¹
284T, 286T	14.62	7.30	1 1/2	13.18	9.62	13.00	3.88	24.52

IntelliGear

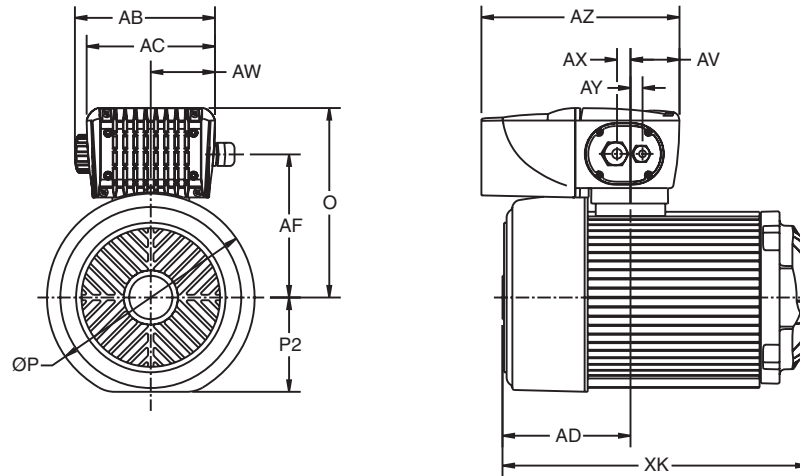

Motor Frame	Controller	O	P	P2	AB	AC	AD	AF	AV	AW	AX	AY	AZ	XK
56	1, 1M	7.74	7.33	3.67	6.45	5.91	4.35	5.61	2.25	2.95	.62	.55	8.53	9.79 ²
143T, 145T	1, 1M	7.74	7.33	3.67	6.45	5.91	4.35	5.61	2.25	2.95	.62	.55	8.53	11.04 ²
145TY	1	7.74	7.33	3.67	6.45	5.91	4.35	5.61	2.25	2.95	.62	.55	8.53	12.04
56	2M	7.74	7.33	3.67	6.45	5.91	4.35	5.61	2.25	2.95	.62	.55	9.12	9.79
145T	2, 2M	7.74	7.33	3.67	6.45	5.91	4.35	5.61	2.25	2.95	.62	.55	9.12	11.04
145TY	2, 2M	7.74	7.33	3.67	6.45	5.91	4.35	5.61	2.25	2.95	.62	.55	9.12	12.04
182T, 184T	2	8.72	9.56	4.78	6.45	5.91	5.89	6.58	2.25	2.95	.62	.55	9.12	14.05
	3	11.16	9.56	4.78	8.97	8.44	10.01	7.37	2.83	4.22	.62	.55	13.10	14.05
213T	3	11.99	11.25	4.98	8.97	8.44	11.73	8.11	2.83	4.22	.62	.55	13.10	16.15
215T	3	11.99	11.25	4.98	8.97	8.44	13.23	8.11	2.83	4.22	.62	.55	13.10	17.65

Input Power Phase/Voltage	Motor HP @ Max. Hz					
	0.33 to 0.50	0.75	1	1.5 to 2	3 to 5	7.5 to 10
1/115	1M	2M	-	-	-	-
1/230	1M	1M	1M	2M	-	-
3/230	1	1	1	2	3	-
3/460	1	1	1	1	2	3

¹ XK = 22.58 on OtN 34 three stage and 27A combined.
² XK will increase by .58" if used on 32 combined.

Dimensional Supplement

OtN Series

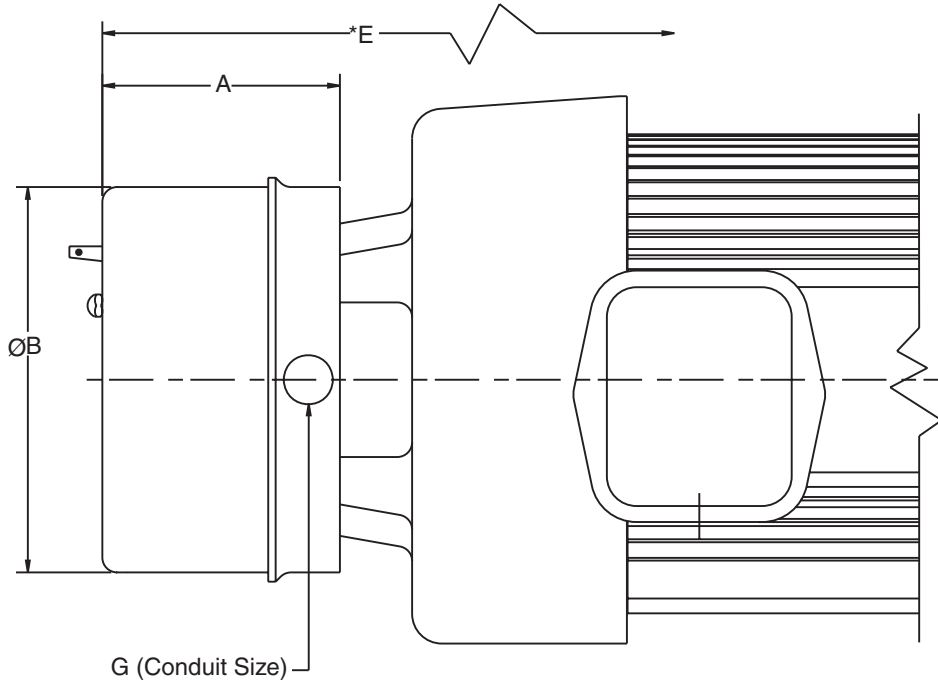

Motor Frame	Brake Torque (ft. lbs.)	A	B	E*	G
56	3	4.01	6.54	4.56	1/2
	6	4.01	6.54	4.56	1/2
143T/145T	3	4.01	6.54	4.56	1/2
	6	4.01	6.54	4.56	1/2
	10	4.01	6.54	4.56	1/2
182T/184T	15	4.01	6.54	4.56	1/2
213T	25	7.38	9.38	8.75	1/2
215T	35	7.38	9.38	8.75	1/2

* Dimension "E" represents the additional length of motor with brake mounted. Add this amount to the gearmotor length "C".

TEFC Three Phase Gearmotors

Gear Frame	Reduction Stages	Motor Frame													
		56	143T	145T	145TY	182T	184T	213T	215T	254T	256T	284T	286T	324T	326T
32	3	77	86	88	89	110	116	-	-	-	-	-	-	-	-
	5	85	-	-	-	-	-	-	-	-	-	-	-	-	-
33	3	99	108	110	111	133	139	167	180	-	-	-	-	-	-
	5,6	129	138	140	-	-	-	-	-	-	-	-	-	-	-
34	3	147	156	158	159	181	187	215	228	273	323	-	-	-	-
	5,6	176	185	188	-	-	-	-	-	-	-	-	-	-	-
35	3	-	231	233	235	252	258	286	299	344	394	444	494	-	-
	5,6	240	250	253	255	275	281	-	-	-	-	-	-	-	-
26	3	-	-	-	-	413	419	455	468	513	563	613	663	-	-
	5,6	420	430	433	435	455	-	-	-	-	-	-	-	-	-
27	3	-	-	-	-	617	623	651	664	709	759	809	859	950	1015
	5,6	615	625	628	630	670	676	678	683	-	-	-	-	-	-
28	3	-	-	-	-	-	-	862	875	920	970	1020	1070	1380	1440
	5,6	930	940	943	945	985	991	993	1000	-	-	-	-	-	-

Motor Options

Motor Type	Motor Frame														
	56	143T	145T	145TY	182T	184T	213T	215T	254T	256T	284T	286T	324T	326T	
C CorroDuty	8	9	11	11	52	50	73	70	190	165	140	160	RO	RO	
X Explosionproof	19	21	25	-	33	30	50	50	140	190	180	165	RO	-	
S Single Phase	6	11	-	5	-	17	-	-	-	-	-	-	-	-	
IG IntelliGear	7	15	18	20	31	30	RO	RO	-	-	-	-	-	-	

Gear Options

Gear Frame	Flange Mount	Footed S1
32	4	-
33	5	2
34	7	3
35	8	5
26	10	-
27	12	-
28	15	-

Browning[®]

OtN Helical Bevel Right Angle Speed Reducers

OtN Series

C-Face

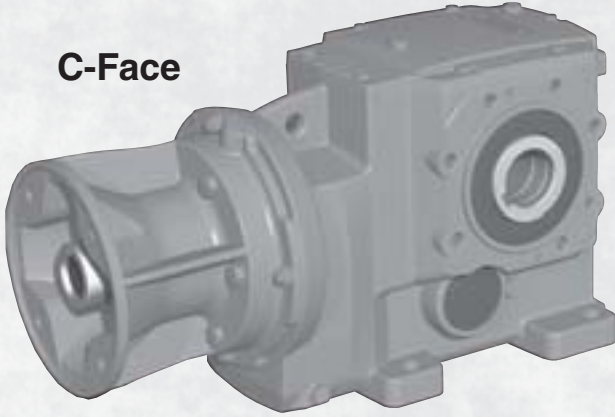

Top Mount

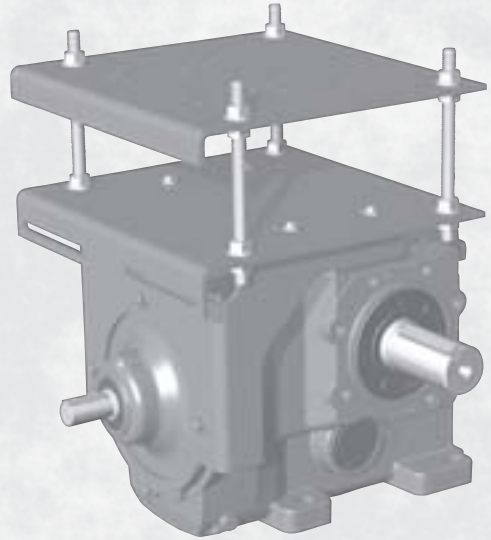

Input Shaft

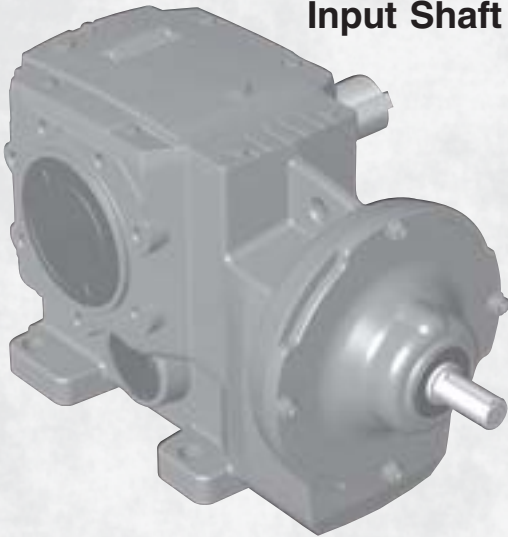

Scoop Mount

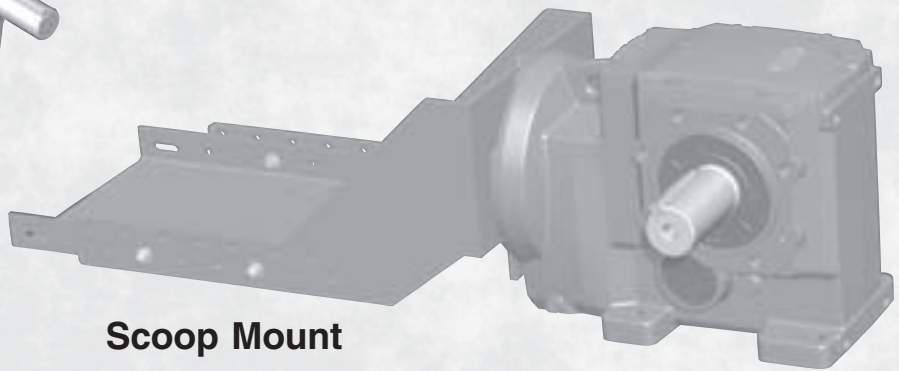

Type OtN Helical Bevel Speed Reducer Features...

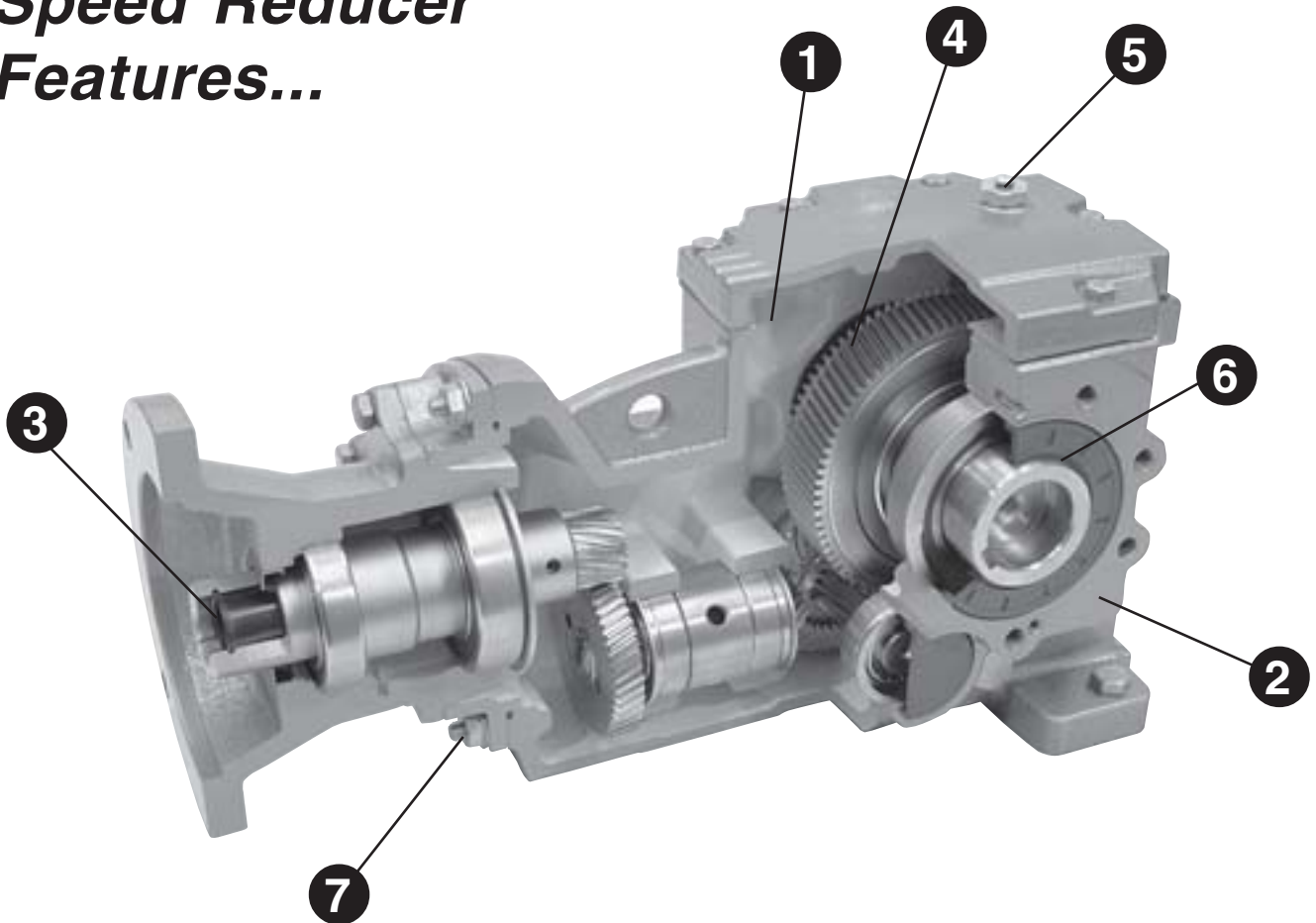

Design Features

- 1. Gearcase Supplied Factory Filled with Synthetic Oil**
 - Wide temperature range and longer life.
- 2. Corrosion and Shock Resistant Cast Iron Housing**
 - One-piece, reinforced and ribbed for extra strength.
- 3. Series 3000 C-Face Reducers with Compact Quill Design**
 - Non-metallic liner to eliminate fretting.
 - Shorter design.
 - Two bearings for support.
- 4. Gears and Shafts of Nickel Chromium Molybdenum Steel**
 - Helical gearing is case hardened and then skived, superfinished or ground.
 - All gears heat shrunk on shafts or mounted on self-locking tapered shafts and keyed for high shock load capability.
- 5. Normally Closed Breather with Multiple Locations (Optional OtN2000)**
- 6. Double Lip Seals on Heat Treated, Plunge Ground Shafts**
- 7. Magnetic Drain Plug Standard**

Table of Contents

Section	Page
Mounting Versatility and Size Range	B-105
Speed Reducer Selection	B-106 - B-107
Catalog Nomenclature	B-108 - B-109
Gearmotor Mounting Positions	B-110
Gearmotor Output Brackets and Shafts	B-111
Modifications, Options and Accessories	B-112
AC Motors	B113
Torque Reaction Arms	B-114 - B-115
Tapered Bushing Selections	B-116
AGMA Application Classifications	B-117 - B-119
Speed Reducer Selection Tables	B-120 - B-125
Dimension Prints	
C-Face Reducers Output Shafted Foot Mount	B-126 - B-129
C-Face Reducers Output Shafted Flange Mount	B-130 - B-133
C-Face Reducers Finished Bore Hollow Shaft	B-134 - B-137
C-Face Reducers Finished Bore Hollow Shaft Face Mount	B-138 - B-141
C-Face Reducers Finished Bore Hollow Shaft Flange Mount	B-142 - B-145
C-Face Reducers Taper Bushed Shaft Mount	B-146 - B-147
Input Shaft Reducers Output Shafted Foot Mount	B-148 - B-149
Input Shaft Reducers Output Shafted Flange Mount	B-150 - B-153
Input Shaft Reducers Finished Bore Hollow Shaft	B-154 - B-155
Input Shaft Reducers Finished Bore Hollow Shaft Face Mount	B-156 - B-159
Input Shaft Reducers Finished Bore Hollow Shaft Flange Mount	B-160 - B-163
Input Shaft Reducers Taper Bushed Shaft Mount	B-164 - B-165
Scoop Mount Reducers Output Shafted Foot Mount	B-166 - B-168
Scoop Mount Reducers Output Shafted Flange Mount	B-169 - B-171
Scoop Mount Reducers Finished Bore Hollow Shaft	B-172 - B-174
Scoop Mount Reducers Finished Bore Hollow Shaft Face Mount	B-175 - B-177
Scoop Mount Reducers Finished Bore Hollow Shaft Flange Mount	B-178 - B-180
Scoop Mount Reducers Taper Bushed Shaft Mount	B-181
Top Mount Reducers Output Shafted Foot Mount	B-182
Top Mount Reducers Finished Bore Hollow Shaft	B-183
Top Mount Reducers Finished Bore Hollow Shaft Face Mount	B-184
Top Mount Reducers Taper Bushed Shaft Mount	B-185
Reducer Weights	B-186
Lubrication	B-187
Gearmotor - Typical Motor Performance Data	E-1 - E-4
IntelliGear Technical Specifications	E-5 - E-9
NEMA Standard Dimensions	E-10
General Information	E-11
Standard Terms and Conditions of Sale	E-12

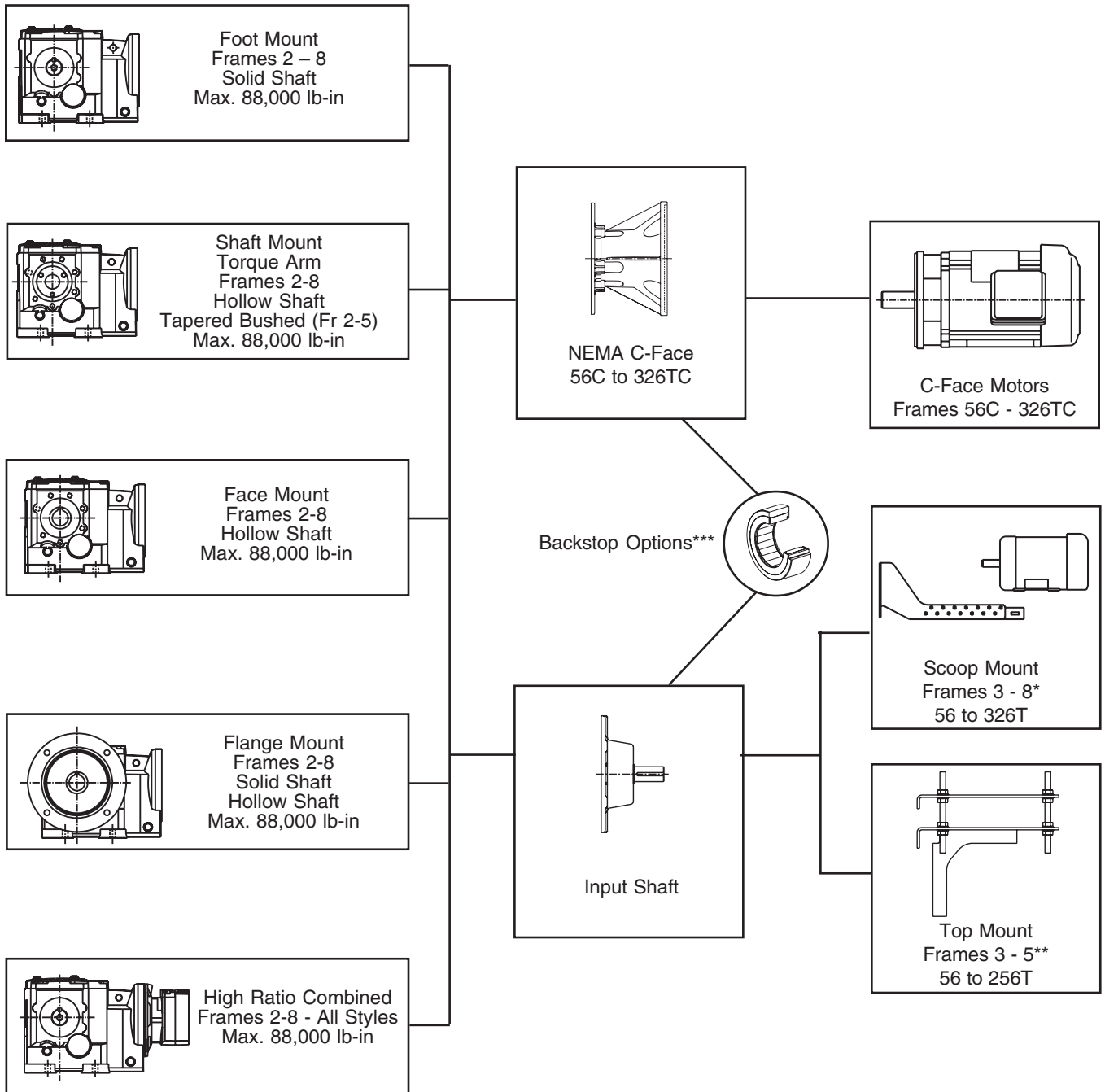

* Not available for frames 2 - 5, 5-stage or frames 4 - 6, 6-stage.

** Only available for frames 3 - 5, 3-stage.

*** Not available for frames 3245 and 3365A. Available input shaft or scoop mount only for frames 6 - 8.

Selection Information

- Input HP**
 - Based on application data.
- Speed/Ratio**
 - Obtain either desired output speed (rpm) or gearbox ratio based on application.
- Service Factor**
 - Determine the required service factor using either the AGMA application classification chart (pages B-117 - B-119), or the duration of operation, load type, and drive type with the table below:

Prime Mover	Hours of Operation	Uniform Load U	Moderate Shock Load M	Heavy Shock Load V
Electric Motor	0 - 3	0.80	1.00	1.50
	3 - 10	1.00	1.25	1.75
	10 - 24	1.25	1.50	2.00
Internal Combustion Engine	0 - 3	1.00	1.25	1.75
	3 - 10	1.25	1.50	2.00
	10 - 24	1.50	1.75	2.25

Size Selection

Step 1

- Locate speed reducer selection tables (pages B-120 - B-125) based on input speed to gearbox.

Step 2

- Choose the nominal ratio appropriate for the speeds required.

Step 3

- Select the gear unit size for the chosen ratio and the known input speed so that the mechanical power rating P (hp) satisfies the following:

$$P \geq P_m \cdot SF$$

P = mechanical power rating (hp) of gearbox

P_m = motor power (hp)

SF = required service factor

Note: Size selection based on absorbed power (Pa) or absorbed torque (Ta) at the low speed shaft instead of motor power (Pm) is allowed when the former is known with sufficient accuracy and if the number of start operations is limited. When Ta is applied in size selection, verify if:

$$T \geq T_a \cdot SF$$

T = torque rating (in. lbs.) at low speed shaft

T_a = absorbed torque (in. lbs.) at low speed shaft

SF = required service factor

Size Selection (cont.)

Step 4

- Verify overhung load ratings where required (see page B-107).

Example

1. Application Data

Bottling conveyor, 24-hrs/day operation. Requires right angle hollow shaft mounted speed reducer to be mounted directly to the conveyor drive shaft with a torque arm. The customer prefers a c-face mounted motor.

Motor rating: 5 HP, 1750 RPM, 184TC Footless Frame, 230/460 VAC, 3-Phase, 60 Hz, TEFC

Output speed: 44 rpm

2. Size Selection

Nominal Ratio: Locate nominal rpm closest to 44 rpm. 40:1 nominal ratio is the proper selection.

Service Factor: Using AGMA application classification chart (page B-117) under the "Brewing and Distilling" heading, bottling machinery that operates over 10 hours/day should have a 1.25 service factor.

Rating Req'd: Minimum reducer rating required is $P = P_m \times SF$
 $P = 5 \text{ HP} \times 1.25 = 6.25 \text{ HP}$

Catalog Rating:

Exact ratio	Gear Frame	39.9	3473
Input H.P.	Output Torque	9.96	13453

Selection: OtN3473 is rated 9.96 HP input /13453 lb-in output with 39.9:1 ratio.
 $1750 \text{ rpm} / 39.9 = 43.9 \text{ rpm}$ output speed.
 $9.96 / 5 = 1.99 \text{ SF}$.

3. Catalog Designation

Reducer: OtN-3473-S2-B33C-40-U-184TC (See page B-108.)

Torque Arm: ROC400KT001 (See page B-114.)

4. Motor Model Number Selection

Part Number: U5S2ACR (See Page B-113.)

Specifications: 5 HP, 1750 rpm, 184TC Footless Frame, 208-230/460 VAC, 3-Phase, 60 Hz, TEFC

When a sprocket, sheave, pulley, or pinion is mounted on the take-off shaft of a reducer, it is necessary to calculate the overhung load. This calculated load must be compared with the gearbox capacity listed to make sure the gearbox will not be overloaded. To calculate the overhung load you need to know the torque or horsepower at the take-off shaft and the location along the shaft at which the load is applied.

Where:

- OHL = Overhung load (pounds)
- T = Torque (in. lbs.)
- r = Radius of driving member (in.)
- HP = Horsepower
- K = Drive type factor
- LLF = Load location factor

A. If torque is known:

$$OHL = \frac{T \times K \times LLF}{r}$$

B. If horsepower is known:

$$OHL = \frac{63025 \times HP \times K \times LLF}{RPM \times r}$$

Driving Member	Value of K
Chain Drive	1.00
Pinion	1.25
Timing Belt	1.25
V-Belt	1.50
Flat Belt	2.50

Load Location	Value of LLF
End of shaft extension	1.20
Center of shaft extension	1.00
Shaft extension shoulder	0.80

Overhung Load (lbs.)							
Output rpm	Frame						
	32	33	34	35	26	27	28
151-175	825	1392	1653	2565	-	-	-
101-150	834	1549	1707	2815	4660	7000	10350
51-100	902	1737	1892	3339	5650	8500	12100
31-50	1148	2090	2435	4100	6060	10300	12100
16-30	1490	2090	2875	4100	6060	11200	12100
5-15	1490	2090	2875	4100	6060	11200	12100
<5	1490	2090	2875	4100	6060	11200	12100

OHL capacities above are calculated at gear capacity rounded to the closest motor HP at mid shaft. For capacity when HP is known, refer to gearmotor selection tables.

Ordering

OtN • 34 7 3 • S2 • B 33 G • 22.4 • U • 145TC • M11

See pages B-110 and B-111

Browning Right-Angle Helical-Bevel	Series	Reducer Size	Stages	Shaft & Foot Dimensions ¹	Mounting Position	Output Face/Flange Right-Left Viewed From Input End	Output Shaft Configuration Viewed from Input End	Nominal Gear Ratio	Input Type	Motor Frame (All Except Input Shaft Type)	Modifications	
Series 3000	32	4	3 = 3 stages	S1 = OtN2000 replacement dimensions	B = Floor mount	3 = Standard round	G = Shaft right	22.4 = 22.4:1	AP = Input Shaft	C-Face 56C-326TC	Select from modifications listed on page B-112	
	33	6	5 or 5A = 5 stages combined	S2 = Industry interchange dimensions	P = Ceiling mount	4 = Face mount	D = Shaft left	Use nominal ratio selected from reducer selection tables	AD = Input Shaft with Backstop	Scoop Mount 143T-326T		
	34	7	6 = 6 stages combined		H = Wall mount, input left	5 = Standard dimension flange mount	X = Dual shaft		SP = Scoop Mount	Top Mount 56-286T		
	35	8			T = Wall mount, input right	6 = Alternate dimension flange mount	C = Finished bore		SD = Scoop Mount with Backstop			
	Series 2000	26	0	3 = 3 stages	S1 = All Series 2000 Units	V = Input vertical up		B = Tapered bushed		U = C-Face		
		27	0	5A = 5 stages combined		W = Input vertical down		S = Screw conveyor shaft and adapter		UD = C-Face with Backstop		
		28	0	6A = 6 stages combined						TM = Top Mount TMD = Top Mount with Backstop		

¹ Shaft and critical mounting dimensions match either OtN2000 or SEW "K" Series units. These dimensions include the mounting base, output flanges, output shaft diameter, distance from housing center line to shaft tip, and output quill diameter. B14 mounting faces and overall product envelope (height, width, depth) do NOT match.

SEW is believed to be a trade name of SEW-Eurodrive GMBH & Co. and is NOT owned or controlled by Emerson Power Transmission. Emerson Power Transmission Corporation cannot and does not represent or warrant the accuracy of this information.

Output Flange Sizes

Flange Dimensions (mm)								
BD	200	250	300	350	400	450	550	
AK	130	180	230	250	300	350	450	
AJ	165	215	265	300	350	400	500	
Gear Frame	Output Flange Part Number Designator							
32	5	6						
33		5	6					
34			5	6				
35				5	6			
26						5		
27						5		
28								5



Speed Reducers Catalog Nomenclature

OtN
SERIES **2000**
3000

OtN Series

C-Face Frames

OtN2000/3000 C-Face Reducers							
Motor Frame	56C	143TC 145TC	182TC 184TC	213TC 215TC	254TC 256TC	284TC 286TC	324TC 326TC
Gear Frame							
3243	10:1 - 160:1	10:1 - 160:1	10:1 - 100:1				
3245	180:1 - 4,500:1	180:1 - 2,800:1					
3363	10:1 - 160:1	10:1 - 160:1	10:1 - 140:1	10:1 - 90:1			
3365	180:1 - 6,300:1	180:1 - 4,000:1	180:1 - 900:1				
3473	10:1 - 160:1	10:1 - 160:1	10:1 - 160:1	10:1 - 100:1	10:1 - 100:1		
3475/3476	180:1 - 10,000:1	180:1 - 10,000:1	180:1 - 2,800:1				
3583	25:1 - 160:1	25:1 - 160:1	25:1 - 160:1	14:1 - 160:1	10:1 - 125:1	10:1 - 56:1	
3585/3586	180:1 - 10,000:1	180:1 - 10,000:1	180:1 - 4,000:1				
2603		12.5:1 - 100:1	12.5:1 - 100:1	12.5:1 - 100:1	12.5:1 - 100:1	12.5:1 - 100:1	
2605/2606	125:1 - 10,000:1	125:1 - 10,000:1	125:1 - 10,000:1	125:1 - 500:1	125:1 - 500:1		
2703			100:1	45:1 - 100:1	22.4:1 - 90:1	12.5:1 - 50:1	
2705/2706	140:1 - 10,000:1	140:1 - 10,000:1	140:1 - 10,000:1	140:1 - 500:1	140:1 - 500:1		
2803				80:1 - 100:1	35.5:1 - 100:1	25:1 - 90:1	12.5:1 - 63:1
2805/2806	112:1 - 9,000:1	112:1 - 9,000:1	112:1 - 9,000:1	112:1 - 2,500:1	112:1 - 630:1	112:1 - 280:1	

Scoop Mount Frames

OtN2000/3000 Scoop Mount Reducers							
Motor Frame	56	143T 145T	182T 184T	213T 215T	254T 256T	284T 286T	324T 326T
Gear Frame							
3243				Not Available			
3245				Not Available			
3363	X	X	-	-	-	-	-
3365				Not Available			
3473	X	X	X	-	-	-	-
3475				Not Available			
3476				Not Available			
3583	-	X	X	X	-	-	-
3585				Not Available			
3586				Not Available			
2603	-	X	X	X	X	X	-
2605	-	X	-	-	-	-	-
2606				Not Available			
2703	-	-	X	X	X	X	X
2705	-	X	X	X	-	-	-
2706	-	X	-	-	-	-	-
2803	-	-	-	-	X	X	X
2805	-	X	X	X	X	-	-
2806	-	X	X	-	-	-	-

Top Mount Frames

OtN2000/3000 Top Mount Reducers					
Motor Frame	56	143T 145T	182T 184T	213T 215T	254T 256T
Gear Frame					
3243				Not Available	
3245				Not Available	
3363	X	X	X	-	-
3365				Not Available	
3473	X	X	X	X	-
3475				Not Available	
3476				Not Available	
3583	-	X	X	X	X
3585				Not Available	
3586				Not Available	
2603				Not Available	
2605				Not Available	
2606				Not Available	
2703				Not Available	
2705				Not Available	
2706				Not Available	
2803				Not Available	
2805				Not Available	
2806				Not Available	

Speed Reducer Position (defined by a letter)

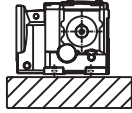

B

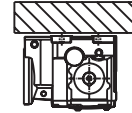
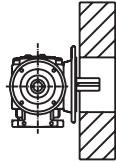

P

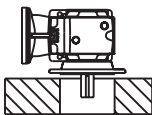
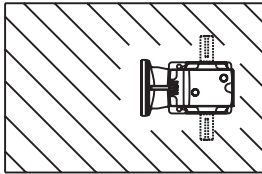
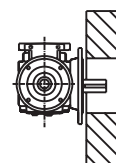

H

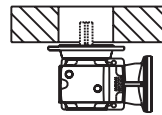
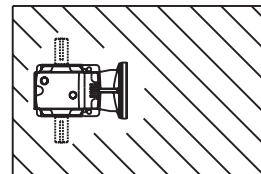
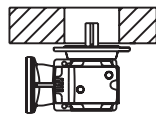

T

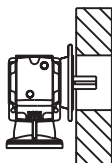
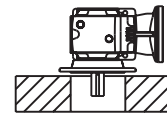

W

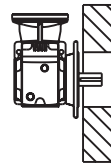
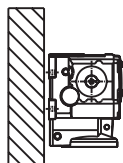

V

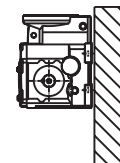

Output Bracket Options

Options

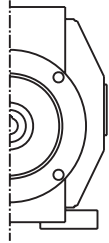

Plain = 3



Face = 4



Flanged = 5 or 6

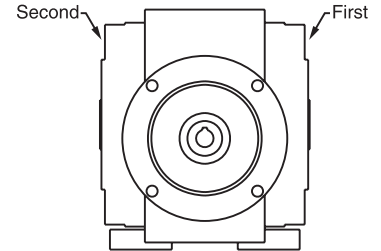

Define in order shown

Note: Viewed reducer input, define each endshield per drawing.

Output Shaft Arrangement

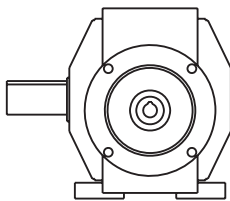

Left = D

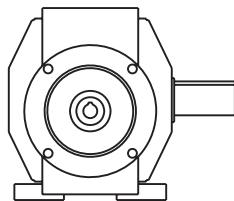

Right = G

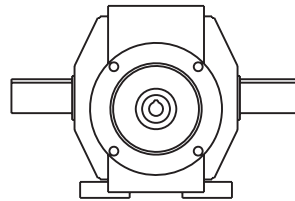

Left / Right = X

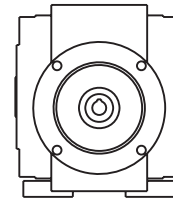

Hollow Bore = C

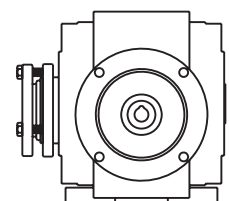

Taper Bushed = B*

* Bushing may be field reversed to opposite side.

Example: Standard floor mount, shaft output on right (facing reducer input).

B

Floor Mount

3

Right Output Endshield

3

Left Output Endshield

G

Shaft Output on Right

OtN Frame	Foot Mounted			Face Mounted			Flange Mounted						Shaft Mounted		
	Solid Shaft			Hollow Shaft			Solid Shaft			Hollow Shaft			Hollow	Bushed	
	33G	33D	33X	33C*	34C	43C	44C*	53G	35D	55X	53C	35C	55C*	33C*	33B*
32	●	●	●	●	●	●	●	●	●	▲	●	●	●	●	●
33	●	●	●	●	●	●	●	●	●	▲	●	●	●	●	●
34	●	●	●	●	●	●	●	●	●	▲	●	●	●	●	●
35	●	●	●	●	●	●	●	●	●	▲	●	●	●	●	●
26	●	●	●	●	●	●	●	●	●	▲	●	●	●	●	-
27	●	●	●	●	●	●	●	●	●	▲	●	●	●	●	-
28	●	●	●	●	●	●	●	●	●	▲	●	●	●	●	-

■ If shaded, the alternative flange "6" is also available.

● This is available at normal lead-times.

▲ This item is available at production lead-times.

- Refer to office for design review.

* This design allows entry of driven shaft from either side of gear housing.

M11 Corro-Duty

Corro-Duty gearmotors are designed for applications in food processing, chemical, poultry and any other industries that will be subjected to extreme humidity, washdown, steam, detergents and mild acids. The Corro-Duty option includes a normally closed breather in the gear case. The exterior of the entire unit is then painted in one of the two options chosen at order entry.

Option #1 - Corro-Duty grey

- 3 step paint system using 316 stainless steel paint
- Light grey semigloss finish
- USDA and FDA approved

Option #2 - Corro-Duty white

- 2 step paint system using epoxy paint
- White gloss finish
- USDA and FDA approved

M12 Normally Closed Breather

This breather protects against lubricant contamination in applications with flying dust, lint or washdown. A normally closed breather is standard on frames sizes 2 through 5, or it may be added to frames 6 through 8 by specifying this option.

M13 NPT Adapter

These adapters convert metric threads of breather, drain and/or oil level holes in the reducer to standard NPT threads. They are required for customer additions of site glasses, sight tubes, special breathers and other plumbing accessories. The adapter(s) is supplied loose for mounting by others.

Gear Frame	Size	Part Number
2 - 5	1/4" NPFT	0436216
6 - 8	3/4" NPFT	0436218

M15 Export Boxing

Export boxing can be provided for "underdeck" transport. When the quantity of OtN gearmotors exceeds five units, refer to the sales department for the most economical accommodations.

M16 Special Nameplate

Units can be provided with limited, additional, special information on the standard product nameplate. When requested, a special nameplate may be provided and stamped with custom markings.

M17 Coupling Guard

For scoop mount series, this kit includes cover, base and hardware.

M18 Oil Level View Port

This clear port is installed in place of the oil level plug. It allows maintenance personnel a convenient means of checking for proper oil level without removing plugs. Proper View Port part numbers are:

Gear Frame	Size	Part Number
2 - 5	1/4" BSPP Male	0435936
6 - 8	3/4" BSPP Male	0435938

Face and Flanged Output (Designated under Brackets and Shafts)

Gearmotors with faced or flanged outputs are available from stock. Refer to page B-108 and individual dimension pages for options available based on gear frame size.

Synthetic Oil

OtN gearmotors are supplied factory-filled with a premium synthetic oil. Refer to page B-187 for complete details of lubricants.

C-Face Footless

HP	Frame	Unimount® TEFC 208-230/460 VAC 3-Ph/60 Hz Std. Efficiency	Unimount TEFC 575 VAC 3-Ph/60 Hz Std. Efficiency	Unimount TEFC 208-230/460 VAC 3-Ph/60 Hz Energy Efficient	Unimount TEFC 575 VAC 3-Ph/60 Hz Energy Efficient	841 Plus® IEEE 841 Duty 460 VAC 3-Ph/60 Hz Premium Efficient	eLine® Severe Duty 208-230/460 VAC 3-Ph/60 Hz Energy Efficient	eLine Severe Duty 575 VAC 3-Ph/60 Hz Energy Efficient
1/4	56C	U14S2ACR						
1/3	56C	U13S2ACR						
1/2	56C	U12S2ACR	U12S2GCR					
3/4	56C	U34S2ACR	U34S2GCR					
1	143TC	U1S2ACR	U1S2GCR			8P1P2CCR	ELT1E2DC▲	ELT1E2GC▲
	56C	U1S2AFCR						
1 1/2	145TC	U32S2ACR	U32S2GCR			8P3P2CCR	ELT3E2DC▲	ELT3E2GC▲
	56C	U32S2AFCR	U32S2GFCR					
2	145TC	U2S2ACR	U2S2GCR			8P2P2CCR	ELT2E2DC▲	ELT2E2GC▲
	56C	U2S2AFCR						
3	182TC	U3S2ACR	U3S2GCR	U3E2DCR	U3E2GCR	8P3P2CCR	ELT3E2DC▲	ELT3E2GC▲
5	184TC	U5S2ACR	U5S2GCR	U5E2DCR	U5E2GCR	8P5P2CCR	ELT5E2DC▲	ELT5E2GC▲
7 1/2	213TC	U7S2ACR	U7S2GCR	U7E2DCR	U7E2GCR	8P7P2CCR	ELT7E2DC▲	ELT7E2GC▲
10	215TC	U10S2ACR	U10S2GCR	U10E2DCR	U10E2GCR	8P10P2CCR	ELT10E2DC▲	ELT10E2GC▲
15	254TC	U15S2ACR		U15E2DCR	U15E2GCR		ELT15E2DC▲	ELT15E2GC▲
20	256TC	U20S2ACR		U20E2DCR	U20E2GCR		ELT20E2DC▲	ELT20E2GC▲
25	284TC	U25S2ACR		U25E2DCR	U25E2GCR		ELT25E2DC▲	ELT25E2GC▲
30	286TC	U30S2ACR		U30E2DCR	U30E2GCR		ELT30E2DC▲	ELT30E2GC▲

▲ C-Face footed motor.

Rigid Base Mount

HP	Frame	Unimount TEFC 208-230/460 VAC 3-Ph/60 Hz Energy Efficient	Unimount TEFC 575 VAC 3-Ph/60 Hz Energy Efficient	Unimount TEFC 200 VAC 3-Ph/60 Hz Energy Efficient	Hostile Duty TEFC 230/460 VAC 3-Ph/60 Hz Energy Efficient	Hostile Duty TEFC 575 VAC 3-Ph/60 Hz Energy Efficient	Hostile Duty TEFC 200 VAC 3-Ph/60 Hz Energy Efficient	eLine Severe Duty 208-230/460 VAC 3-Ph/60 Hz Energy Efficient	eLine Severe Duty 575 VAC 3-Ph/60 Hz Energy Efficient
1	143T	U1E2D	U1E2G	U1E2H	H1E2D	H1E2G	H1E2H	ELT1E2D	ELT1E2G
1 1/2	145T	U32E2D	U32E2G	U32E2H	H32E2D	H32E2G	H32E2H	ELT32E2D	ELT32E2G
2	145T	U2E2D	U2E2G	U2E2H	H2E2D	H2E2G	H2E2H	ELT2E2D	ELT2E2G
3	182T	U3E2D	U3E2G	U3E2H	H3E2D	H3E2G	H3E2H	ELT3E2D	ELT3E2G
5	184T	U5E2D	U5E2G	U5E2H	H5E2D	H5E2G	H5E2H	ELT5E2D	ELT5E2G
7 1/2	213T	U7E2D	U7E2G	U7E2H	H7E2D	H7E2G	H7E2H	ELT7E2D	ELT7E2G
10	215T	U10E2D	U10E2G	U10E2H	H10E2D	H10E2G	H10E2H	ELT10E2D	ELT10E2G
15	254T	U15E2D	U15E2G	U15E2H	H15E2D	H15E2G	H15E2H	ELT15E2D	ELT15E2G
20	256T	U20E2D	U20E2G	U20E2H	H20E2D	H20E2G	H20E2H	ELT20E2D	ELT20E2G
25	284T	U25E2D	U25E2G	U25E2H	H25E2D	H25E2G	H25E2H	ELT25E2D	ELT25E2G
30	286T	U30E2D	U30E2G	U30E2H	H30E2E	H30E2G	H30E2H	ELT30E2D	ELT30E2G
40	324T				H40E2E	H40E2G	H40E2H	ELT40E2D	
50	326T				H50E2E	H50E2G	H50E2H	ELT50E2D	

Unimount, 841 Plus and eLine are registered trademarks of Emerson Electric Co.

Emerson Power Transmission Corporation cannot and does not represent or warrant the accuracy of this information.

Torque Reaction Arm

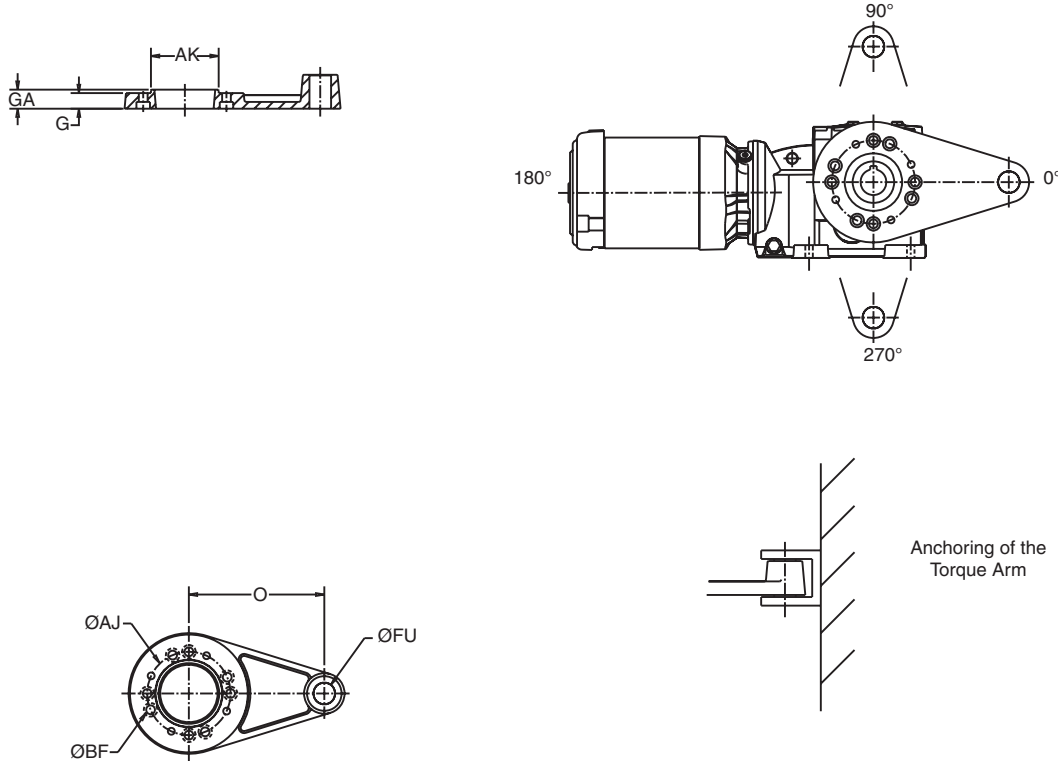

- Torque arm can be assembled in any of the three positions shown in the drawing above relative to the input (motor) when called out on the order.
- If torque arm is requested on an assembly order and no mounting position is called for, the default position is 0°.

- Torque arm can be affixed to either side of the 33C or 33B gear housing.

Series 3000

OtN Frame	Part ID # Kit	G	O	AJ	AK	BF	FU	GA
32	ROC200KT001	.63	5.118	3.94	3.150	.43	.87	.79
33	ROC300KT001	.91	7.874	4.84	3.937	.51	1.260	1.10
34	ROC400KT001	-	9.842	5.98	5.118	.51	1.260	.91
35	ROC500KT001	-	12.205	7.48	6.102	.67	1.260	.98

Torque Reaction Arm

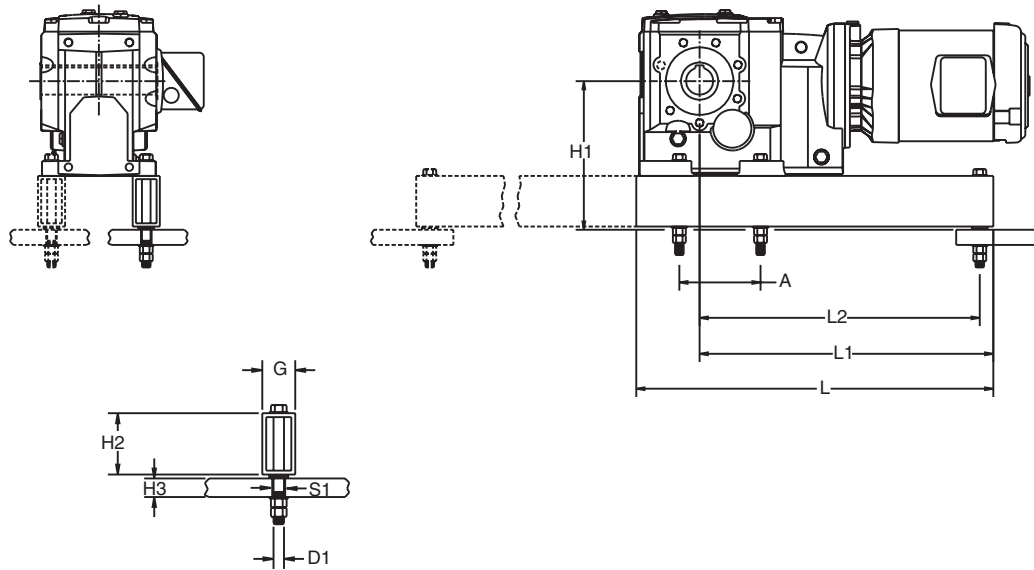

- Torque arm can be assembled with attachment point on the input side or 180° opposite this, as shown above.
- Torque arm can be attached onto feet on either side of the gear housing as you face opposite the input (motor).

Series 2000

Gear Frame	Part Number	A	D1	G	H1	H2	H3 max.	L	L1	L2	S1 min.
26	0986479	13.98	.75	2.50	13.61	4.50	1.50	35.83	27.46	26.08	0.81
27	0986479	16.54	.75	2.50	14.59	4.50	1.50	35.83	26.18	24.80	0.81
28	0986480	20.08	.88	4.00	18.67	6.00	1.88	43.31	31.69	30.12	0.94

Each Series 3000 OtN can be ordered with a Tapered Bushed Output. This "33B" mounting configuration will include the appropriate bushing kit unassembled when a bore is defined at order entry. The table below shows the various stocked bushing bores for each OtN frame that can be specified. Each bushing kit is supplied with bushing, hardware for mounting and a stabilizer ring. If bushings are required as a spare or bore changed in the field, refer to the OtN 3000 frame and select the required kit from below.

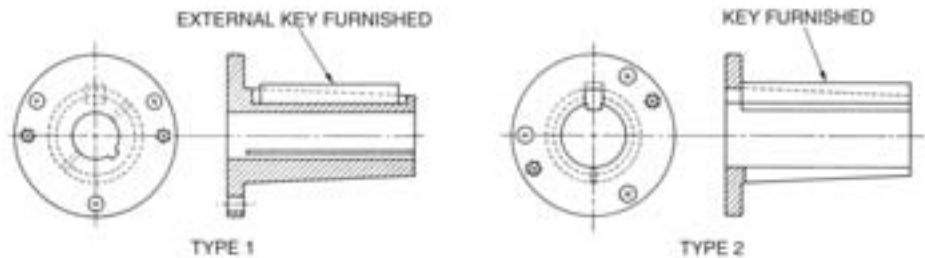
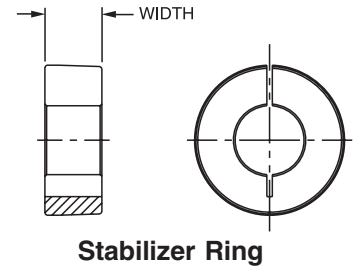

OtN Frame	Mea. Unit	Bushing No.	Bore	Shaft Keyseat Required	Type	Stabilizer Ring Width	Bolt Torque		Weight (lbs.)	
							Bolt Size	Ft.-lbs.		
32 33	Inch	107TBP012	3/4	3/16 x 3/32 x 3 7/8	1	0.793	5/16 -18 x 1 1/4	16	2.6	
		107TBP014	7/8	3/16 x 3/32 x 3 7/8	1				2.5	
		107TBP015	15/16	1/4 x 1/8 x 3 7/8	2				2.4	
		107TBP100	1	1/4 x 1/8 x 3 7/8	2				2.3	
		107TBP101	1 1/16	1/4 x 1/8 x 3 7/8	2				2.1	
		107TBP102	1 1/8	1/4 x 1/8 x 3 7/8	2				2.0	
		107TBP103	1 3/16	1/4 x 1/8 x 3 7/8	2				1.9	
		107TBP104	1 1/4	1/4 x 1/8 x 3 7/8	2				1.8	
		107TBP105	1 5/16	5/16 x 5/32 x 3 7/8	2				1.6	
		107TBP106	1 3/8	5/16 x 5/32 x 3 7/8	2				1.5	
		107TBP107	1 7/16	3/8 x 3/16 x 3 7/8	2				1.5	
		Metric *	107TBP30MM	30 mm	8 x 4 x 94 (mm)				2	1.9
			107TBP35MM	35 mm	10 x 5 x 94 (mm)				2	1.5
		34	Inch	115TBP015	15/16				1/4 x 1/8 x 4 1/8	1
115TBP100	1			1/4 x 1/8 x 4 1/8	1	5.9				
115TBP101	1 1/16			1/4 x 1/8 x 4 1/8	1	5.7				
115TBP102	1 1/8			1/4 x 1/8 x 4 1/8	1	5.6				
115TBP103	1 3/16			1/4 x 1/8 x 4 1/8	1	5.4				
115TBP104	1 1/4			1/4 x 1/8 x 4 1/8	1	5.3				
115TBP105	1 5/16			5/16 x 5/32 x 4 1/8	2	5.1				
115TBP106	1 3/8			5/16 x 5/32 x 4 1/8	2	4.8				
115TBP107	1 7/16			3/8 x 3/16 x 4 1/8	2	4.7				
115TBP108	1 1/2			3/8 x 3/16 x 4 1/8	2	4.4				
115TBP110	1 5/8			3/8 x 3/16 x 4 1/8	2	4.0				
115TBP111	1 11/16			3/8 x 3/16 x 4 1/8	2	3.7				
115TBP112	1 3/4			3/8 x 3/16 x 4 1/8	2	3.5				
115TBP114	1 7/8			1/2 x 1/4 x 4 1/8	2	3.1				
115TBP115	1 15/16			1/2 x 1/4 x 4 1/8	2	2.7				
Metric *	115TBP40MM	40 mm	12 x 5 x 100 (mm)	2	4.0					
	115TBP45MM	45 mm	14 x 5.5 x 100 (mm)	2	3.5					
35	Inch	207TBP106	1 3/8	5/16 X 5/32 x 5 1/8	1	1.040	3/8-16 X 1 1/4	29	9.6	
		207TBP107	1 7/16	3/8 X 3/16 X 5 1/8	1				9.3	
		207TBP108	1 1/2	3/8 X 3/16 X 5 1/8	1				9.1	
		207TBP110	1 5/8	3/8 X 3/16 X 5 1/8	2				8.5	
		207TBP111	1 11/16	3/8 X 3/16 X 5 1/8	2				8.3	
		207TBP112	1 3/4	3/8 X 3/16 X 5 1/8	2				7.9	
		207TBP114	1 7/8	1/2 X 1/4 X 5 1/8	2				7.3	
		207TBP115	1 15/16	1/2 X 1/4 X 5 1/8	2				6.9	
		207TBP200	2	1/2 X 1/4 X 5 1/8	2				6.6	
		207TBP202	2 1/8	1/2 X 1/4 X 5 1/8	2				5.9	
		207TBP203	2 3/16	1/2 X 1/4 X 5 1/8	2				5.5	
		207TBP204	2 1/4	1/2 X 1/4 X 5 1/8	2				5.1	
		207TBP207	2 7/16	5/8 X 5/16 X 5 1/8	2				3.9	
		Metric *	207TBP50MM	50 mm	14 x 5.5 x 125 (mm)				2	6.6
			207TBP60MM	60 mm	18 x 7 x 125 (mm)				2	4.5

* Metric bushings have metric bores and require metric keyseats as shown in mm.



Speed Reducers

OtN
SERIES **2000**
3000

AGMA Application Classifications

Application	Service Factor			Application	Service Factor		
	Up to 3 hrs/day	Up to 10 hrs/day	Over 10 hrs/day		Up to 3 hrs/day	Up to 10 hrs/day	Over 10 hrs/day
Agitators (Mixers)				Cranes (Continued)			
Pure Liquids	—	1.00	1.25	Boom Hoist	Refer to Application Engineering		
Liquids & Solids	1.00	1.25	1.50	Trolley Drive	Refer to Application Engineering		
Liquids - Variable Density	1.00	1.25	1.50	(Gantry Drive)			
				(Traction Drive)	Refer to Application Engineering		
Blowers				Mill Duty			
Centrifugal	1.00	1.25	—	Main	Refer to Application Engineering		
Lobe	1.00	1.25	1.50	Auxiliary	Refer to Application Engineering		
Vane	—	1.00	1.25	Bridge & Trolley Travel	Refer to Application Engineering		
Brewing and Distilling				Industrial Duty			
Bottling Machinery	—	1.00	1.25	Main	1.25	1.50	1.75
Brew Kettles, Continuous Duty	—	1.00	1.25	Auxiliary	Refer to Application Engineering		
Cookers - Continuous Duty	—	1.00	1.25	Bridge & Trolley Travel	Refer to Application Engineering		
Mash Tubs - Continuous Duty	—	1.00	1.25				
Scale Hoppers, Frequent Starts	1.00	1.25	1.50	Crusher			
				Stone or Ore	1.50	1.75	2.00
Can Filling Machines	—	1.00	1.25	Dredges			
Car Dumpers	1.25	1.50	1.75	Cable Reels	1.00	1.25	1.50
Car Pullers	1.00	1.25	1.50	Conveyors	1.00	1.25	1.50
Clarifiers	—	1.00	1.25	Cutter Head Drives	1.25	1.50	1.75
Classifiers	1.00	1.25	1.50	Pumps	1.00	1.25	1.50
Clay Working Industry				Screen Drives	1.25	1.50	1.75
Brick Press	1.25	1.50	1.75	Stackers	1.00	1.25	1.50
Brique Machine	1.25	1.50	1.75	Winches	1.00	1.25	1.50
Pug Mill	1.00	1.25	1.50				
Compactors	1.50	1.75	2.00	Elevators			
Compressors				Bucket	1.00	1.25	1.50
Centrifugal	—	1.00	1.25	Centrifugal Discharge	—	1.00	1.25
Lobe	1.00	1.25	1.50	Escalators	Refer to Application Engineering		
Reciprocating, Multi - Cylinder	1.00	1.25	1.50	Freight	Refer to Application Engineering		
Reciprocating, Single - Cylinder	1.25	1.50	1.75	Gravity Discharge	—	1.00	1.25
Conveyors - General Purpose				Extruders			
Uniformly Loaded or Fed	—	1.00	1.25	General	1.25	1.25	1.25
Not Uniformly Fed	1.00	1.25	1.50	Plastics			
Reciprocating or Shaker	1.25	1.50	1.75	(a) Variable Speed Drive	1.50	1.50	1.50
				(b) Fixed Speed Drive	1.75	1.75	1.75
Cranes				Rubber			
Dry Dock				(a) Continuous Screw Operation	1.50	1.50	1.50
Main Hoist	1.25	1.50	1.75	(b) Intermittent Screw Operation	1.75	1.75	1.75
Auxiliary	1.25	1.50	1.75	Fans			
Boom Hoist	1.25	1.50	1.75	Centrifugal	—	1.00	1.25
Slewing Drive	1.25	1.50	1.75	Cooling Towers	Refer to Application Engineering		
Traction Drive	1.50	1.50	1.50	Forced Draft	1.25	1.25	1.25
Container				Induced Draft	1.00	1.25	1.50
Main Hoist	Refer to Application Engineering			Industrial & Mine	1.00	1.25	1.50

OtN Series



Speed Reducers

OtN
SERIES **2000**
3000

AGMA Application Classifications

OtN Series

Application	Service Factor			Application	Service Factor		
	Up to 3 hrs/day	Up to 10 hrs/day	Over 10 hrs/day		Up to 3 hrs/day	Up to 10 hrs/day	Over 10 hrs/day
Feeders				Metal Mills			
Apron	—	1.25	1.50	Draw Bench Carriage & Main Drive	1.00	1.25	1.50
Belt	1.00	1.25	1.50	Runout Table			
Disc	—	1.00	1.25	Non-reversing			
Reciprocating	1.25	1.50	1.75	Group Drives	1.00	1.25	1.50
Screw	1.00	1.25	1.50	Individual Drives	1.50	1.50	1.75
Food Industry				Reversing	1.50	1.50	1.75
Cereal Cooker	—	1.00	1.25	Slab Pushers	1.25	1.25	1.50
Dough Mixers	1.00	1.25	1.50	Shears	1.50	1.50	1.75
Meat Grinders	1.00	1.25	1.50	Wire Drawing	1.00	1.25	1.50
Slicers	1.00	1.25	1.50	Wire Winding Machine	1.00	1.25	1.50
Generators and Exciters	—	1.00	1.25	Metal Strip Processing Machinery			
Hammer Mills	1.50	1.50	1.75	Bridles	1.25	1.25	1.50
Hoists				Coilers & Uncoilers	1.00	1.00	1.25
Heavy Duty	1.25	1.50	1.75	Edge Trimmers	1.00	1.25	1.50
Medium Duty	1.00	1.25	1.50	Flatteners	1.00	1.25	1.50
Skip Hoist	1.00	1.25	1.50	Loopers (Accumulators)	1.00	1.00	1.00
Laundry Tumblers	1.00	1.25	1.50	Pinch Rolls	1.00	1.25	1.50
Laundry Washers	1.00	1.25	1.50	Scrap Choppers	1.00	1.25	1.50
Lumber Industry				Shears	1.50	1.50	1.75
Barkers				Slitters	1.00	1.25	1.50
- Spindle Feed	1.25	1.25	1.25	Mills, Rotary Type			
- Main Drive	1.50	1.50	1.50	Ball & Rod			
Conveyors				Spur Ring Gear	1.50	1.50	1.75
- Burner	1.25	1.25	1.50	Helical Ring Gear	1.50	1.50	1.50
- Main or Heavy Duty	1.50	1.50	1.50	Direct Connected	1.50	1.50	1.75
- Main Log	1.50	1.50	1.50	Cement Kilns	1.50	1.50	1.50
- Re-Saw, Merry-Go-Round	1.25	1.25	1.50	Dryers & Coolers	1.50	1.50	1.50
- Slab	1.50	1.50	1.75	Mixers, Concrete	1.00	1.25	1.50
- Transfer	1.25	1.25	1.50	Paper Mills			
Chains				Agitator (Mixer)	1.50	1.50	1.50
- Floor	1.50	1.50	1.50	Agitator for Pure Liquids	1.25	1.25	1.25
- Green	1.50	1.50	1.50	Barkers - Mechanical	1.75	1.75	1.75
Cut-Off Saws				Barking Drums	1.75	1.75	1.75
- Chain	1.50	1.50	1.50	Beater	1.50	1.50	1.50
- Drag	1.50	1.50	1.50	Breaker Stack	1.25	1.25	1.25
Debarking Drums	1.50	1.50	1.75	❖Calender	1.25	1.25	1.25
Feeds				Chipper	1.75	1.75	1.75
- Edger	1.25	1.25	1.50	Chip Feeder	1.50	1.50	1.50
- Gang	1.50	1.50	1.50	Coating Rolls	1.25	1.25	1.25
- Trimmer	1.25	1.25	1.50	Conveyors			
Log Deck	1.50	1.50	1.50	Chip, Bark, Chemical	1.25	1.25	1.25
Log Hauls - Incline-Well Type	1.50	1.50	1.50	Log (Including Slab)	1.75	1.75	1.75
Log Turning Devices	1.50	1.50	1.50	Couch Rolls	1.25	1.25	1.25
Planner Feed	1.25	1.25	1.25	Cutter	1.75	1.75	1.75
Planer Tilting Hoists	1.50	1.50	1.50	Cylinder Molds	1.25	1.25	1.25
Rolls - Live-Off Bearing.-Roll Cases	1.50	1.50	1.50	❖Dryers			
Sorting Table	1.25	1.25	1.50	Paper Machine	1.25	1.25	1.25
Tipple Hoist	1.25	1.25	1.50	Conveyor Type	1.25	1.25	1.25
Transfers				Embosses	1.25	1.25	1.25
- Chain	1.50	1.50	1.50	Extruder	1.50	1.50	1.50
- Causeway	1.50	1.50	1.50	Fourdrinier Rolls (Includes Lump Breaker, Dandy Roll, Wire Turning, and Return Rolls)	1.25	1.25	1.25
Tray Drives	1.25	1.25	1.50	Jordan	1.25	1.25	1.25
Veneer Lathe Drives	Refer to Application Engineering			Kiln Drive	1.50	1.50	1.50
				Mt. Hope Roll	1.25	1.25	1.25



Speed Reducers

OtN
SERIES 2000
3000

AGMA Application Classifications

Application	Service Factor			Application	Service Factor		
	Up to 3 hrs/day	Up to 10 hrs/day	Over 10 hrs/day		Up to 3 hrs/day	Up to 10 hrs/day	Over 10 hrs/day
Paper Mills (Continued)				Rubber Industry			
Paper Rolls	1.25	1.25	1.25	Intensive Internal Mixers			
Platter	1.50	1.50	1.50	(a) Batch Mixers	1.50	1.75	1.75
Presses - Felt & Suction	1.25	1.25	1.25	(b) Continuous Mixers	1.25	1.50	1.50
Pulper	1.50	1.50	1.75	Mixing Mill - 2 Smooth Rolls - (If corrugated rolls are used, then use the same service factors that are used for a Cracker-Warmer)	1.50	1.50	1.50
Pumps - Vacuum	1.50	1.50	1.50	Batch Drop Mill - 2 Smooth Rolls	1.50	1.50	1.50
Reel (Surface Type)	1.25	1.25	1.50	Cracker Warmer - 1 Corrugated Roll	1.75	1.75	1.75
Screens				Cracker - 2 Corrugated Rolls	1.75	1.75	1.75
Chip	1.50	1.50	1.50	Holding, Feed & Blend Mill - 2 Rolls	1.25	1.25	1.25
Rotary	1.50	1.50	1.50	Refiner - 2 Rolls	1.50	1.50	1.50
Vibrating	1.75	1.75	1.75	Calenders	1.50	1.50	1.50
Size Press	1.25	1.25	1.25	Sand Miller	1.00	1.25	1.50
Super Calender (See Note)	1.25	1.25	1.25	Sewage Disposal			
Thickner				Bar Screens	—	1.00	1.25
(AC Motor)	1.50	1.50	1.50	Chemical Feeders	—	1.00	1.25
(DC Motor)	1.25	1.25	1.25	Dewatering Screens	1.00	1.25	1.50
Washer				Scum Breakers	1.00	1.25	1.50
(AC Motor)	1.50	1.50	1.50	Slow or Rapid Mixers	1.00	1.25	1.50
(DC Motor)	1.25	1.25	1.25	Sludge Collectors	1.00	1.00	1.25
Wind and Unwind Stand	1.00	1.00	1.00	Thickeners	1.00	1.25	1.50
Winders (Surface Type)	1.25	1.25	1.25	Vacuum Filters	1.00	1.25	1.50
❖Yankee Dryers	1.25	1.25	1.25	Screens			
Plastics Industry - Primary Processing				Air Washing	—	1.00	1.25
Intensive Internal Mixers				Rotary - Stone or Gravel	1.00	1.25	1.50
(a) Batch Mixers	1.75	1.75	1.75	Traveling Water Intake	—	1.00	1.25
(b) Continuous Mixers	1.50	1.50	1.50	Sugar Industry			
Batch Drop Mill - 2 Smooth Rolls	1.25	1.25	1.25	Beet Slicer	1.50	1.50	1.75
Continuous Feed, Holding & Blend Mill	1.25	1.25	1.25	Cane Knives	1.50	1.50	1.50
Compounding Mills	1.25	1.25	1.25	Crushers	1.50	1.50	1.50
Calenders	1.50	1.50	1.50	Mills (Low Speed End)	1.50	1.50	1.50
Plastics Industry - Secondary Processing				Textile Industry			
Blow Molders	1.50	1.50	1.50	Batchers	1.00	1.25	1.50
Coating	1.25	1.25	1.25	Calenders	1.00	1.25	1.50
Film	1.25	1.25	1.25	Cards	1.00	1.25	1.50
Pipe	1.25	1.25	1.25	Dry Cans	1.00	1.25	1.50
Pre-Plasticizers	1.50	1.50	1.50	Dryers	1.00	1.25	1.50
Rods	1.25	1.25	1.25	Dyeing Machinery	1.00	1.25	1.50
Sheet	1.25	1.25	1.25	Looms	1.00	1.25	1.50
Tubing	1.25	1.25	1.50	Mangles	1.00	1.25	1.50
Pullers - Barge Haul	1.00	1.50	1.75	Nappers	1.00	1.25	1.50
Pumps				Pads	1.00	1.25	1.50
Centrifugal	—	1.00	1.25	Slashers	1.00	1.25	1.50
Proportioning	1.00	1.25	1.50	Soapers	1.00	1.25	1.50
Reciprocating				Spinners	1.00	1.25	1.50
Single Acting, 3 or more cylinders	1.00	1.25	1.50	Tenter Frames	1.00	1.25	1.50
Double Acting, 2 or more cylinders	1.00	1.25	1.50	Washers	1.00	1.25	1.50
Rotary				Winders	1.00	1.25	1.50
- Gear	—	1.00	1.50				
- Lobe	—	1.00	1.25				
- Vane	—	1.00	1.25				

OtN Series

❖ Anti-friction bearings only.

NOTE: A service factor of 1.0 may be applied at the base of a super calender, operating over a speed range where part of the range is constant horsepower and part of the range is constant torque, provided that the constant horsepower part is greater than 1.5 to 1. A service factor of 1.25 is applicable to super calenders operating over the entire speed range at constant torque, or where the constant horsepower speed range is less than 1.5 to 1.



Speed Reducers

Motor rpm 1750

OtN
SERIES **2000**
3000

OtN Series

Exact Ratio rpm, HP and Torque

Nom. rpm	Nom. Ratio	Size of OtN 2000/3000 Reducer													
		32		33		34		35		26		27		28	
175	10	9.80	3243	9.78	3363	9.51	3473	9.47	3583						
		7.44	2468	15.62	5172	25.20	8113	54.65	17520						
140	12.5	12.4	3243	12.3	3363	12.3	3473	12.3	3583	12.4	2603	12.4	2703	12.7	2803
		7.04	2955	13.31	5542	23.08	9610	45.48	18938	54.79	23000	73.85	31000	104.67	45000
125	14	13.9	3243	14.8	3363	15.2	3473	14.9	3583						
		6.37	2997	12.06	6042	22.45	11552	38.69	19516						
109	16	16.1	3243	16.1	3363	15.5	3473	15.5	3583	15.7	2603	15.7	2703	15.7	2803
		6.07	3308	11.68	6366	22.27	11686	35.13	18434	53.62	28500	75.26	40000	103.48	55000
97	18	16.6	3243	18.6	3363	17.5	3473	18.7	3583						
		5.33	2995	10.01	6303	19.65	11641	32.70	20701						
88	20	20.4	3243	20.3	3363	20.1	3473	20.0	3583	19.9	2603	19.9	2703	20.1	2803
		5.11	3529	9.92	6817	18.14	12343	29.43	19926	44.53	30000	69.77	47000	104.34	71000
78	22.4	22.9	3243	23.3	3363	21.3	3473	23.6	3583	22.5	2603	22.5	2703	22.8	2803
		4.72	3659	8.61	6791	15.90	11465	26.36	21060	39.39	30000	63.02	48000	103.65	80000
70	25	24.1	3243	24.3	3363	24.8	3473	24.3	3583	25.5	2603	25.5	2703	25.5	2803
		4.53	3696	8.48	6976	15.23	12787	25.63	21084	34.75	30000	55.60	48000	99.62	86000
63	28	27.3	3243	28.7	3363	28.6	3473	27.1	3583	27.7	2603	27.7	2703	28.3	2803
		4.08	3771	7.47	7258	13.43	13003	23.40	21468	31.99	30000	51.19	48000	89.77	86000
56	31.5	30.8	3243	30.6	3363	31.5	3473	30.5	3583	31.6	2603	31.6	2703	32.5	2803
		3.69	3848	6.89	7137	12.61	13447	21.20	21890	28.04	30000	44.87	48000	79.07	87000
49	35.5	34.8	3243	34.6	3363	34.8	3473	34.0	3583	36.2	2603	36.2	2703	35.7	2803
		3.30	3888	5.93	6946	11.41	13442	19.34	22261	24.48	30000	39.17	48000	71.99	87000
44	40	39.5	3243	38.3	3363	39.9	3473	38.6	3583	39.8	2603	39.8	2703	39.4	2803
		2.92	3905	5.37	6963	9.96	13453	17.11	22358	22.27	30000	35.63	48000	65.23	87000
39	45	45.2	3243	43.7	3363	44.1	3473	42.6	3583	43.9	2603	43.9	2703	43.7	2803
		2.56	3917	4.72	6983	9.01	13451	15.55	22426	20.19	30000	32.30	48000	58.81	87000
35	50	51.0	3243	50.3	3363	50.6	3473	49.8	3583	51.4	2603	51.4	2703	50.8	2803
		2.27	3919	4.11	6999	7.85	13447	13.37	22540	17.24	30000	27.59	48000	50.59	87000
31	56	54.1	3243	53.8	3363	57.0	3473	55.5	3583	57.5	2603	57.5	2703	57.9	2803
		2.14	3919	3.85	7012	7.06	13623	12.03	22603	15.41	30000	24.66	48000	44.39	87000
28	63	64.3	3243	61.0	3363	61.9	3473	62.4	3583	64.9	2603	64.9	2703	64.8	2803
		1.81	3940	3.41	7042	6.58	13789	10.73	22667	13.65	30000	22.30	49000	39.66	87000
25	71	68.0	3243	67.8	3363	69.0	3473	70.6	3583	70.0	2603	70.0	2703	70.2	2803
		1.71	3936	3.07	7046	6.01	14039	9.52	22753	12.66	30000	20.68	49000	36.61	87000
22	80	77.7	3243	77.0	3363	77.5	3473	80.6	3583	79.1	2603	79.1	2703	81.0	2803
		1.50	3946	2.71	7064	5.37	14089	8.36	22811	11.20	30000	18.30	49000	32.09	88000
19	90	86.7	3243	85.7	3363	87.7	3473	86.5	3583	87.1	2603	87.1	2703	87.4	2803
		1.35	3962	2.44	7079	4.76	14132	7.81	22870	10.17	30000	16.62	49000	29.74	88000
18	100	97.2	3243	96.4	3363	95.4	3473	101	3583	99.5	2603	99.5	2703	102	2803
		1.21	3982	2.17	7082	4.38	14146	6.71	22943	8.91	30000	14.55	49000	25.46	88000
16	112	113	3243	113	3363	108	3473	109	3583						
		1.04	3978	1.86	7115	3.88	14186	6.23	22989						
14	125	124	3243	125	3363	124	3473	121	3583						
		0.95	3988	1.68	7109	3.39	14231	5.62	23021						
12.5	140	142	3243	137	3363	139	3473	134	3583						
		0.83	3990	1.54	7142	3.03	14258	5.09	23090						
10.9	160	156	3243	160	3363	154	3473	159	3583						
		0.76	4014	1.32	7150	2.74	14285	4.30	23146						

Exact ratio	Gear Frame
Input H.P.	Output Torque



Speed Reducers

Motor rpm 1450

OtN
SERIES **2000**
3000

Exact Ratio rpm, HP and Torque

Nom. rpm	Nom. Ratio	Size of OtN 2000/3000 Reducer													
		32		33		34		35		26		27		28	
145	10	9.80	3243	9.78	3363	9.51	3473	9.47	3583						
		5.73	2294	13.60	5434	21.23	8249	47.56	19577						
116	12.5	12.4	3243	12.3	3363	12.3	3473	12.3	3583	12.4	2603	12.4	2703	12.7	2803
		5.40	2736	11.59	5825	17.72	8905	39.58	19891	45.40	23000	61.19	31000	86.72	45000
104	14	13.9	3243	14.8	3363	15.2	3473	14.9	3583						
		5.28	2999	10.01	6053	15.76	9788	32.82	19980						
91	16	16.1	3243	16.1	3363	15.5	3473	15.5	3583	15.7	2603	15.7	2703	15.7	2803
		5.26	3460	9.05	5953	15.58	9867	30.58	19366	44.43	28500	62.36	40000	85.74	55000
81	18	16.6	3243	18.6	3363	17.5	3473	18.7	3583						
		4.55	3086	8.03	6102	13.85	9903	27.49	21003						
73	20	20.4	3243	20.3	3363	20.1	3473	20.0	3583	19.9	2603	19.9	2703	20.1	2803
		4.45	3709	7.76	6436	12.98	10660	25.61	20927	36.90	30000	57.81	47000	86.45	71000
65	22.4	22.9	3243	23.3	3363	21.3	3473	23.6	3583	22.5	2603	22.5	2703	22.8	2803
		4.10	3836	6.81	6483	12.07	10504	22.31	21512	32.63	30000	52.21	48000	85.88	80000
58	25	24.1	3243	24.3	3363	24.8	3473	24.3	3583	25.5	2603	25.5	2703	25.5	2803
		3.93	3870	6.75	6702	11.20	11349	22.28	22120	28.79	30000	46.07	48000	82.54	86000
52	28	27.3	3243	28.7	3363	28.6	3473	27.1	3583	27.7	2603	27.7	2703	28.3	2803
		3.48	3882	5.87	6883	10.14	11849	20.07	22222	26.51	30000	42.41	48000	74.38	86000
46	31.5	30.8	3243	30.6	3363	31.5	3473	30.5	3583	31.6	2603	31.6	2703	32.5	2803
		3.09	3888	5.50	6876	9.48	12201	17.90	22306	23.24	30000	37.18	48000	65.52	87000
41	35.5	34.8	3243	34.6	3363	34.8	3473	34.0	3583	36.2	2603	36.2	2703	35.7	2803
		2.75	3910	4.93	6969	8.84	12569	16.12	22393	20.28	30000	32.45	48000	59.65	87000
36	40	39.5	3243	38.3	3363	39.9	3473	38.6	3583	39.8	2603	39.8	2703	39.4	2803
		2.43	3922	4.47	6995	8.03	13091	14.25	22474	18.45	30000	29.52	48000	54.04	87000
32	45	45.2	3243	43.7	3363	44.1	3473	42.6	3583	43.9	2603	43.9	2703	43.7	2803
		2.13	3934	3.93	7017	7.49	13496	12.95	22540	16.73	30000	26.76	48000	48.73	87000
29	50	51.0	3243	50.3	3363	50.6	3473	49.8	3583	51.4	2603	51.4	2703	50.8	2803
		1.89	3938	3.42	7029	6.78	14017	11.13	22646	14.29	30000	22.86	48000	41.92	87000
26	56	54.1	3243	53.8	3363	57.0	3473	55.5	3583	57.5	2603	57.5	2703	57.9	2803
		1.78	3935	3.20	7034	6.04	14066	10.02	22721	12.77	30000	20.43	48000	36.78	87000
23	63	64.3	3243	61.0	3363	61.9	3473	62.4	3583	64.9	2603	64.9	2703	64.8	2803
		1.50	3941	2.83	7053	5.56	14062	8.93	22767	11.31	30000	18.48	49000	32.86	87000
20	71	68.0	3243	67.8	3363	69.0	3473	70.6	3583	70.0	2603	70.0	2703	70.2	2803
		1.42	3945	2.55	7064	5.00	14096	7.92	22846	10.49	30000	17.13	49000	30.33	87000
18	80	77.7	3243	77.0	3363	77.5	3473	80.6	3583	79.1	2603	79.1	2703	81.0	2803
		1.25	3968	2.25	7079	4.47	14154	6.96	22920	9.28	30000	15.16	49000	26.59	88000
16	90	86.7	3243	85.7	3363	87.7	3473	86.5	3583	87.1	2603	87.1	2703	87.4	2803
		1.12	3967	2.03	7108	3.95	14154	6.49	22937	8.43	30000	13.77	49000	24.64	88000
15	100	97.2	3243	96.4	3363	95.4	3473	101	3583	99.5	2603	99.5	2703	102	2803
		1.00	3971	1.81	7129	3.64	14188	5.58	23027	7.38	30000	12.05	49000	21.10	88000
13	112	113	3243	113	3363	108	3473	109	3583						
		0.86	3971	1.54	7110	3.22	14209	5.18	23069						
12	125	124	3243	125	3363	124	3473	121	3583						
		0.79	4002	1.40	7150	2.81	14236	4.67	23087						
10.4	140	142	3243	137	3363	139	3473	134	3583						
		0.69	4003	1.28	7165	2.51	14255	4.23	23159						
9.1	160	156	3243	160	3363	154	3473	159	3583						
		0.63	4015	1.10	7191	2.27	14283	3.57	23192						

Exact ratio	Gear Frame
Input H.P.	Output Torque

OtN Series



Speed Reducers

Motor rpm 1160

OtN
SERIES **2000**
3000

OtN Series

Exact Ratio rpm, HP and Torque

Nom. rpm	Nom. Ratio	Size of OtN 2000/3000 Reducer															
		32		33		34		35		26		27		28			
116	10	9.80	3243	9.78	3363	9.51	3473	9.47	3583								
		5.29	2648	11.78	5884	17.42	8461	39.91	19303								
93	12.5	12.4	3243	12.3	3363	12.3	3473	12.3	3583	12.4	2603	12.4	2703	12.7	2803		
		5.08	3217	9.62	6043	15.36	9649	33.05	20762	36.32	23000	48.95	31000	69.38	45000		
83	14	13.9	3243	14.8	3363	15.2	3473	14.9	3583								
		4.65	3301	8.43	6372	14.71	11419	26.80	20394								
73	16	16.1	3243	16.1	3363	15.5	3473	15.5	3583	15.7	2603	15.7	2703	15.7	2803		
		4.55	3741	8.10	6660	14.59	11550	26.49	20970	35.54	28500	49.89	40000	68.59	55000		
64	18	16.6	3243	18.6	3363	17.5	3473	18.7	3583								
		3.89	3298	6.78	6441	12.58	11243	22.20	21202								
58	20	20.4	3243	20.3	3363	20.1	3473	20.0	3583	19.9	2603	19.9	2703	20.1	2803		
		3.70	3855	6.64	6884	12.03	12349	21.56	22022	29.52	30000	46.24	47000	69.16	71000		
52	22.4	22.9	3243	23.3	3363	21.3	3473	23.6	3583	22.5	2603	22.5	2703	22.8	2803		
		3.32	3883	5.74	6830	10.46	11379	18.66	22491	26.11	30000	41.77	48000	68.70	80000		
46	25	24.1	3243	24.3	3363	24.8	3473	24.3	3583	25.5	2603	25.5	2703	25.5	2803		
		3.16	3889	5.60	6950	10.09	12780	18.00	22339	23.04	30000	36.86	48000	66.04	86000		
41	28	27.3	3243	28.7	3363	28.6	3473	27.1	3583	27.7	2603	27.7	2703	28.3	2803		
		2.80	3904	4.76	6977	8.90	13000	16.20	22422	21.21	30000	33.93	48000	59.50	86000		
37	31.5	30.8	3243	30.6	3363	31.5	3473	30.5	3583	31.6	2603	31.6	2703	32.5	2803		
		2.49	3917	4.48	7001	8.36	13449	14.44	22493	18.59	30000	29.74	48000	52.41	87000		
33	35.5	34.8	3243	34.6	3363	34.8	3473	34.0	3583	36.2	2603	36.2	2703	35.7	2803		
		2.21	3928	3.97	7015	7.66	13614	13.00	22574	16.23	30000	25.96	48000	47.72	87000		
29	40	39.5	3243	38.3	3363	39.9	3473	38.6	3583	39.8	2603	39.8	2703	39.4	2803		
		1.95	3934	3.59	7022	6.82	13898	11.49	22651	14.76	30000	23.61	48000	43.24	87000		
26	45	45.2	3243	43.7	3363	44.1	3473	42.6	3583	43.9	2603	43.9	2703	43.7	2803		
		1.71	3947	3.16	7053	6.21	13987	10.44	22714	13.38	30000	21.41	48000	38.98	87000		
23	50	51.0	3243	50.3	3363	50.6	3473	49.8	3583	51.4	2603	51.4	2703	50.8	2803		
		1.52	3959	2.75	7065	5.45	14084	8.96	22789	11.43	30000	18.29	48000	33.53	87000		
21	56	54.1	3243	53.8	3363	57.0	3473	55.5	3583	57.5	2603	57.5	2703	57.9	2803		
		1.43	3951	2.58	7089	4.85	14119	8.06	22846	10.22	30000	16.35	48000	29.42	87000		
18	63	64.3	3243	61.0	3363	61.9	3473	62.4	3583	64.9	2603	64.9	2703	64.8	2803		
		1.21	3974	2.28	7103	4.48	14163	7.19	22914	9.05	30000	14.78	49000	26.29	87000		
16	71	68.0	3243	67.8	3363	69.0	3473	70.6	3583	70.0	2603	70.0	2703	70.2	2803		
		1.14	3959	2.05	7098	4.02	14166	6.37	22968	8.39	30000	13.71	49000	24.27	87000		
15	80	77.7	3243	77.0	3363	77.5	3473	80.6	3583	79.1	2603	79.1	2703	81.0	2803		
		1.00	3968	1.81	7118	3.59	14210	5.60	23052	7.43	30000	12.13	49000	21.27	88000		
13	90	86.7	3243	85.7	3363	87.7	3473	86.5	3583	87.1	2603	87.1	2703	87.4	2803		
		0.90	3985	1.63	7134	3.18	14243	5.22	23061	6.74	30000	11.02	49000	19.71	88000		
12	100	97.2	3243	96.4	3363	95.4	3473	101	3583	99.5	2603	99.5	2703	102	2803		
		0.80	3971	1.45	7139	2.93	14276	4.49	23161	5.90	30000	9.64	49000	16.88	88000		
10	112	113	3243	113	3363	108	3473	109	3583								
		0.69	3982	1.24	7156	2.59	14286	4.16	23158								
9	125	124	3243	125	3363	124	3473	121	3583								
		0.63	3990	1.12	7150	2.26	14312	3.75	23174								
8.3	140	142	3243	137	3363	139	3473	134	3583								
		0.55	3989	1.03	7207	2.02	14340	3.40	23268								
7.3	160	156	3243	160	3363	154	3473	159	3583								
		0.50	3984	0.88	7191	1.82	14314	2.87	23306								

Exact ratio	Gear Frame
Input H.P.	Output Torque



Speed Reducers

Motor rpm 870

OtN
SERIES **2000**
3000

OtN Series

Exact Ratio rpm, HP and Torque

Nom. rpm	Nom. Ratio	Size of OtN 2000/3000 Reducer													
		32		33		34		35		26		27		28	
87	10	9.8	3243	9.78	3363	9.51	3473	9.47	3583						
		4.03	2689	9.11	6067	13.07	8464	30.73	19817						
70	12.5	12.4	3243	12.3	3363	12.3	3473	12.3	3583	12.4	2603	12.4	2703	12.7	2803
		3.81	3217	7.32	6131	12.57	10528	25.21	21115	27.24	23000	36.71	31000	52.03	45000
62	14	13.9	3243	14.8	3363	15.2	3473	14.9	3583						
		3.68	3483	6.47	6521	11.30	11696	21.29	21601						
54	16	16.1	3243	16.1	3363	15.5	3473	15.5	3583	15.7	2603	15.7	2703	15.7	2803
		3.53	3870	6.29	6896	11.05	11663	20.88	22039	26.66	28500	37.41	40000	51.44	55000
48	18	16.6	3243	18.6	3363	17.5	3473	18.7	3583						
		2.93	3312	5.22	6612	9.82	11702	16.81	21406						
44	20	20.4	3243	20.3	3363	20.1	3473	20.0	3583	19.9	2603	19.9	2703	20.1	2803
		2.81	3904	5.05	6981	9.20	12592	16.45	22404	22.14	30000	34.68	47000	51.87	71000
39	22.4	22.9	3243	23.3	3363	21.3	3473	23.6	3583	22.5	2603	22.5	2703	22.8	2803
		2.51	3914	4.31	6838	8.37	12140	14.05	22579	19.58	30000	31.33	48000	51.53	80000
35	25	24.1	3243	24.3	3363	24.8	3473	24.3	3583	25.5	2603	25.5	2703	25.5	2803
		2.39	3922	4.23	7000	7.94	13409	13.62	22537	17.28	30000	27.64	48000	49.53	86000
31	28	27.3	3243	28.7	3363	28.6	3473	27.1	3583	27.7	2603	27.7	2703	28.3	2803
		2.11	3923	3.60	7036	7.08	13789	12.25	22606	15.90	30000	25.45	48000	44.63	86000
28	31.5	30.8	3243	30.6	3363	31.5	3473	30.5	3583	31.6	2603	31.6	2703	32.5	2803
		1.88	3943	3.38	7043	6.48	13900	10.92	22680	13.94	30000	22.31	48000	39.31	87000
25	35.5	34.8	3243	34.6	3363	34.8	3473	34.0	3583	36.2	2603	36.2	2703	35.7	2803
		1.67	3957	2.99	7045	5.92	14029	9.83	22759	12.17	30000	19.47	48000	35.79	87000
22	40	39.5	3243	38.3	3363	39.9	3473	38.6	3583	39.8	2603	39.8	2703	39.4	2803
		1.47	3954	2.71	7068	5.19	14101	8.68	22815	11.07	30000	17.71	48000	32.43	87000
19	45	45.2	3243	43.7	3363	44.1	3473	42.6	3583	43.9	2603	43.9	2703	43.7	2803
		1.29	3971	2.38	7082	4.71	14144	7.88	22859	10.04	30000	16.06	48000	29.24	87000
17	50	51.0	3243	50.3	3363	50.6	3473	49.8	3583	51.4	2603	51.4	2703	50.8	2803
		1.14	3959	2.07	7090	4.11	14162	6.77	22958	8.57	30000	13.71	48000	25.15	87000
16	56	54.1	3243	53.8	3363	57.0	3473	55.5	3583	57.5	2603	57.5	2703	57.9	2803
		1.08	3979	1.94	7107	3.66	14206	6.08	22978	7.66	30000	12.26	48000	22.07	87000
14	63	64.3	3243	61.0	3363	61.9	3473	62.4	3583	64.9	2603	64.9	2703	64.8	2803
		0.91	3984	1.72	7145	3.37	14205	5.42	23031	6.79	30000	11.09	49000	19.72	87000
12	71	68.0	3243	67.8	3363	69.0	3473	70.6	3583	70.0	2603	70.0	2703	70.2	2803
		0.86	3982	1.55	7156	3.03	14237	4.81	23124	6.29	30000	10.28	49000	18.20	87000
11	80	77.7	3243	77.0	3363	77.5	3473	80.6	3583	79.1	2603	79.1	2703	81.0	2803
		0.75	3968	1.36	7131	2.70	14249	4.22	23162	5.57	30000	9.10	49000	15.95	88000
10	90	86.7	3243	85.7	3363	87.7	3473	86.5	3583	87.1	2603	87.1	2703	87.4	2803
		0.68	4015	1.23	7178	2.39	14273	3.94	23208	5.06	30000	8.26	49000	14.79	88000
9	100	97.2	3243	96.4	3363	95.4	3473	101	3583	99.5	2603	99.5	2703	102	2803
		0.60	3971	1.09	7155	2.20	14292	3.38	23247	4.43	30000	7.23	49000	12.66	88000
8	112	113	3243	113	3363	108	3473	109	3583						
		0.52	4001	0.93	7156	1.95	14341	3.14	23307						
7	125	124	3243	125	3363	124	3473	121	3583						
		0.48	4053	0.84	7150	1.70	14355	2.83	23318						
6.2	140	142	3243	137	3363	139	3473	134	3583						
		0.42	4061	0.77	7183	1.52	14387	2.56	23360						
5.4	160	156	3243	160	3363	154	3473	159	3583						
		0.38	4037	0.66	7191	1.37	14367	2.16	23387						

Exact ratio	Gear Frame
Input H.P.	Output Torque



Speed Reducers

Combined - Motor rpm 1750

OtN
SERIES **2000**
3000

OtN Series

Exact Ratio rpm, HP and Torque

Nom. rpm	Nom. Ratio	Size of OtN 2000/3000 Reducer													
		32		33		34		35		26		27		28	
16	112												110	2805A	
													24.955	88650	
14	125								123.2	2605A			121	2805A	
									8.114	32400			22.678	88650	
12.5	140								142.2	2605A	142.2	2705A	135	2805A	
									7.030	32400	10.631	49000	20.290	88650	
10.9	160								156.7	2605A	156.7	2705A	152	2805A	
									6.379	32400	9.647	49000	18.053	88650	
9.7	180	178	3245	174	3365	172	3475	174	3585	173	2605A	173	2705A	169	2805A
		0.686	3960	1.252	7060	2.523	14065	4.051	22845	5.778	32400	8.738	49000	16.184	88650
8.8	200	197	3245	196	3365	194	3475	184	3585	199	2605A	199	2705A	192	2805A
		0.620	3960	1.111	7060	2.237	14065	3.831	22845	5.023	32400	7.597	49000	14.245	88650
7.8	224	207	3245	222	3365	220	3475	208	3585	219	2605A	219	2705A	212	2805A
		0.590	3960	0.981	7060	1.972	14065	3.389	22845	4.564	32400	6.903	49000	12.901	88650
7.0	250	246	3245	252	3365	250	3475	235	3585	252	2605A	252	2705A	247	2805A
		0.497	3960	0.864	7060	1.736	14065	2.999	22845	3.967	32400	5.999	49000	11.073	88650
6.3	280	263	3245	288	3365	286	3475	265	3585	284	2605A	284	2705A	276	2805A
		0.465	3960	0.756	7060	1.517	14065	2.660	22845	3.520	32400	5.323	49000	9.910	88650
5.6	315	295	3245	325	3365	322	3475	302	3585	308	2605A	308	2705A	310	2805A
		0.414	3960	0.670	7060	1.348	14065	2.334	22845	3.245	32400	4.908	49000	8.823	88650
4.9	355	343	3245	345	3365	342	3475	345	3585	344	2605A	344	2705A	351	2805A
		0.356	3960	0.631	7060	1.286	14259	2.043	22845	2.906	32400	4.395	49000	7.792	88650
4.4	400	370	3245	410	3365	386	3475	389	3585	386	2605A	386	2705A	400	2805A
		0.330	3960	0.531	7060	1.140	14259	1.812	22845	2.590	32400	3.916	49000	6.838	88650
3.9	450	435	3245	434	3365	437	3475	413	3585	436	2605A	436	2705A	430	2805A
		0.281	3960	0.502	7060	1.007	14259	1.707	22845	2.293	32400	3.467	49000	6.361	88650
3.5	500	488	3245	496	3365	482	3475	490	3585	475	2605A	475	2705A	500	2805A
		0.250	3960	0.439	7060	0.914	14286	1.438	22845	2.104	32400	3.183	49000	5.470	88650
3.1	560	549	3245	553	3365	548	3475	518	3585	537	2605A	537	2705A	542	2805A
		0.223	3960	0.394	7060	0.804	14286	1.361	22845	1.861	32400	2.815	49000	5.046	88650
2.8	630	617	3245	620	3365	626	3475	592	3585	618	2605A	618	2705A	599	2805A
		0.198	3960	0.351	7060	0.704	14286	1.191	22845	1.617	32400	2.446	49000	4.566	88650
2.5	710	718	3245	734	3365	707	3475	661	3585	690	2605A	690	2705A	665	2805A
		0.173	4032	0.303	7215	0.623	14286	1.066	22845	1.449	32400	2.191	49000	4.113	88650
2.2	800	793	3245	829	3365	750	3475	741	3585	764	2605A	764	2705A	789	2805A
		0.157	4032	0.269	7215	0.588	14286	0.951	22845	1.308	32400	1.979	49000	3.466	88650
1.9	900	835	3245	937	3365	891	3475	866	3585	904	2606A	904	2706A	857	2806A
		0.149	4032	0.238	7215	0.495	14286	0.835	23447	1.131	32400	1.710	49000	3.264	88650
1.8	1000	991	3245	1010	3365A	942	3475	976	3585	1038	2606A	1038	2706A	1002	2806A
		0.126	4032	0.221	7246	0.468	14286	0.741	23447	0.985	32400	1.490	49000	2.792	88650
1.6	1120	1062	3245	1116	3365A	1185	3475	1105	3585	1169	2606A	1169	2706A	1118	2806A
		0.117	4032	0.200	7246	0.376	14436	0.655	23447	0.875	32400	1.323	49000	2.502	88650
1.4	1250	1189	3245	1175	3365A	1355	3475	1255	3585	1269	2606A	1269	2706A	1256	2806A
		0.105	4032	0.190	7246	0.329	14436	0.576	23447	0.806	32400	1.218	49000	2.227	88650
1.3	1400	1384	3245	1394	3365A	1529	3475	1319	3585	1415	2606A	1415	2706A	1421	2806A
		0.090	4032	0.160	7246	0.291	14436	0.550	23500	0.722	32400	1.093	49000	1.968	88650
1.1	1600	1493	3245	1494	3365A	1622	3475	1499	3585	1588	2606A	1588	2706A	1622	2806A
		0.083	4032	0.150	7246	0.275	14436	0.484	23500	0.644	32400	0.974	49000	1.725	88650

Exact ratio	Gear Frame
Input H.P.	Output Torque



Speed Reducers

Combined - Motor rpm 1750 (Continued)

OtN
SERIES **2000**
3000

OtN Series

Exact Ratio rpm, HP and Torque

Nom. rpm	Nom. Ratio	Size of OtN 2000/3000 Reducer													
		32		33		34		35		26		27		28	
0.97	1800	1756	3245	1673	3365A	1926	3475	1713	3585	1797	2606A	1797	2706A	1741	2806A
		0.071	4032	0.134	7246	0.231	14436	0.423	23500	0.569	32400	0.860	49000	1.607	88650
0.88	2000	1968	3245	1947	3365A	2037	3475	1933	3585	1955	2606A	1955	2706A	2026	2806A
		0.063	4032	0.115	7246	0.219	14436	0.375	23500	0.523	32400	0.791	49000	1.381	88650
0.78	2240	2213	3245	2100	3365A	2329	3475	2051	3585	2209	2606A	2209	2706A	2198	2806A
		0.056	4032	0.106	7246	0.191	14436	0.353	23500	0.463	32400	0.700	49000	1.273	88650
0.70	2500	2488	3245	2470	3365A	2599	3475	2436	3585	2544	2606A	2544	2706A	2428	2806A
		0.050	4032	0.091	7246	0.171	14436	0.298	23500	0.402	32400	0.608	49000	1.152	88650
0.63	2800	2804	3245	2768	3365A	2914	3475	2576	3585	2843	2606A	2843	2706A	2696	2806A
		0.044	4032	0.081	7246	0.153	14436	0.281	23500	0.360	32400	0.544	49000	1.038	88650
0.56	3150	3158	3245	3113	3365A	3374	3475	2944	3585	3147	2606A	3147	2706A	3196	2806A
		0.039	4032	0.072	7246	0.132	14436	0.246	23500	0.325	32400	0.491	49000	0.875	88650
0.49	3550	3474	3245	3500	3365A	3705	3475	3286	3585	3824	2606A	3824	2706A	3500	2806A
		0.036	4032	0.064	7246	0.120	14436	0.221	23500	0.267	32400	0.404	49000	0.799	88650
0.44	4000	3920	3245	3945	3365A	4248	3475	3685	3585	4154	2606A	4154	2706A	3960	2806A
		0.032	4032	0.057	7246	0.105	14436	0.197	23500	0.246	32400	0.372	49000	0.706	88650
0.39	4500	4410	3245	4443	3365A	4437	3476	4266	3585	4629	2606A	4629	2706A	4522	2806A
		0.028	4032	0.050	7246	0.103	14419	0.170	23500	0.221	32400	0.334	49000	0.619	88650
0.35	5000			4887	3365A	5071	3476	4684	3585	5195	2606A	5195	2706A	4853	2806A
				0.046	7246	0.090	14419	0.155	23500	0.197	32400	0.298	49000	0.576	88650
0.31	5600			5515	3365A	5721	3476	5371	3585	5881	2606A	5881	2706A	5647	2806A
				0.041	7246	0.080	14419	0.135	23500	0.174	32400	0.263	49000	0.495	88650
0.28	6300			6204	3365A	6071	3476	6625	3586	6397	2606A	6397	2706A	6128	2806A
				0.036	7246	0.075	14419	0.111	23385	0.160	32400	0.242	49000	0.456	88650
0.25	7100					7210	3476	7008	3586	7230	2606A	7230	2706A	6769	2806A
						0.063	14419	0.105	23385	0.141	32400	0.214	49000	0.413	88650
0.22	8000					7626	3476	8009	3586	8325	2606A	8325	2706A	7517	2806A
						0.060	14419	0.092	23385	0.123	32400	0.186	49000	0.372	88650
0.19	9000					8715	3476	8938	3586	9303	2606A	9303	2706A	8910	2806A
						0.052	14419	0.083	23385	0.110	32400	0.166	49000	0.314	88650
0.18	10000					9727	3476	10023	3586	10297	2606A	10297	2706A		
						0.047	14419	0.074	23385	0.099	32400	0.150	49000		

Exact ratio	Gear Frame
Input H.P.	Output Torque

3-Stage Output Shafted Foot Mount OtN32 - 35

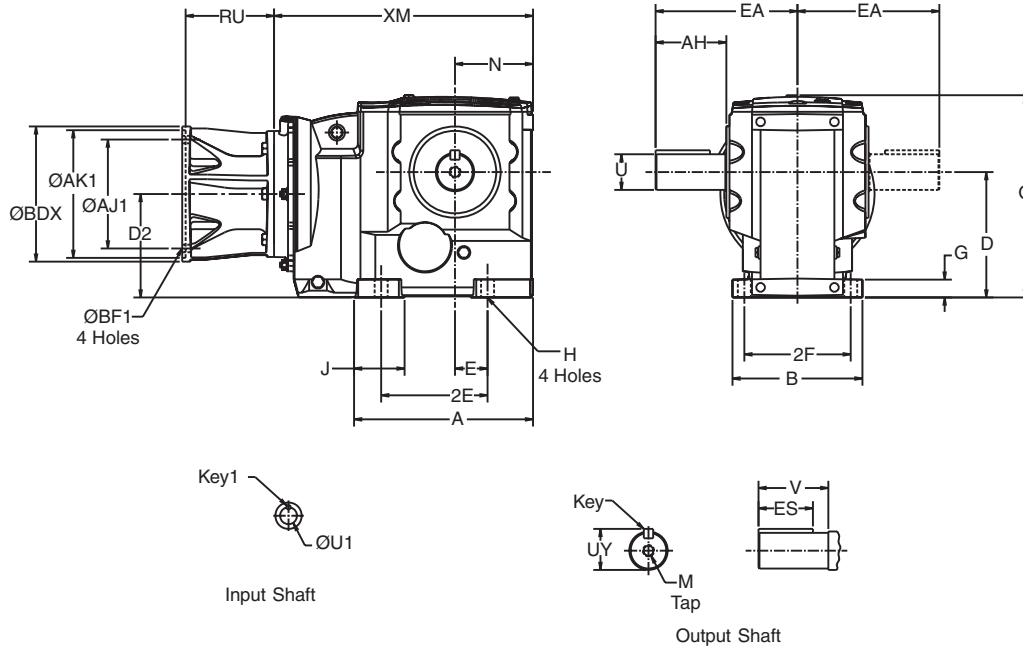

Gear Frame	Version	A	B	D ¹	D2	E	2E	2F	G	H	J	O	N	XM	
														56C-215TC	254TC-286TC
32	S2	7.81	5.71	4.41	3.78	1.38	5.12	4.72	.73	.43	2.34	8.09	3.03	10.98	-
33	S2	8.50	6.61	5.51	5.24	1.18	4.72	5.51	.85	.55	2.86	9.69	3.54	12.90	-
	S1	8.08	8.58	4.92	5.20	3.35	6.69	6.10	.79	.55	2.27	10.43	3.54		
34	S2	10.13	7.87	7.09	5.90	1.57	5.91	6.50	1.07	.71	2.67	12.05	4.49	14.56	-
	S1	10.69	9.60	6.30	7.49	4.53	9.06	7.68	1.18	.71	3.19	13.39	4.49		
35	S2	11.92	8.66	8.35	6.89	2.17	7.09	7.09	1.18	.87	3.37	13.58	5.20	16.90	17.25
	S1	13.07	10.98	7.87	9.33	5.51	11.02	9.06	1.40	.87	4.05	16.22	5.20		

Output Shaft

Gear Frame	Version	U ³	UY	V	AH	EA	Key	ES	M
32	S2	1.250	1.354	2.36	2.46	5.31	1/4 Sq.	2.06	1/2-13 X 1.12
33	S2	1.625	1.783	3.25	3.39	6.73	3/8 Sq.	2.78	5/8-11 X 1.38
	S1	1.500	1.657	3.18	3.19	7.12	3/8 Sq.	2.78	5/8-11 X 1.38
34	S2	2.000	2.210	3.63	3.76	8.11	1/2 Sq.	3.06	3/4-10 X 1.61
	S1	1.750	1.909	3.56	3.66	8.46	3/8 Sq.	3.56	3/4-10 X 1.61
35	S2	2.375	2.638	4.61	4.74	9.45	5/8 Sq.	3.81	3/4-10 X 1.61
	S1	2.375	2.638	5.73	5.27	10.57	5/8 Sq.	4.81	3/4-10 X 1.61

C-Face Input

Motor Frame	Gear Frame	AJ1	AK1	BF1	U1	RU	BDX	Key1
56C	Any	5.88	4.50	.38	.625	3.54	6.50	3/16 Sq.
143TC/145TC	Any	5.88	4.50	.38	.875	3.54	6.50	3/16 Sq.
182TC/184TC	Any	7.25	8.50	.50	1.125	5.26	9.00	1/4 Sq.
213TC/215TC	33,34,35	7.25	8.50	.50	1.375	5.26	9.00	5/16 Sq.
254TC/256TC	35	7.25	8.50	.50	1.625	6.12	9.00	3/8 Sq.
284TC/286TC	35	9.00	10.50	.50	1.875	7.09	11.25	1/2 Sq.

¹ Dimension "D" will never be exceeded, but may vary from values shown. ³ Output shaft extension tolerances: +.0000"; -.0005" for shafts up to 1.5" diameter "U". Larger diameter "U", +.000"; -.001".
² All rough casting dimensions may vary by .25" due to casting variations.

3-Stage Output Shafted Foot Mount OtN26 - 28

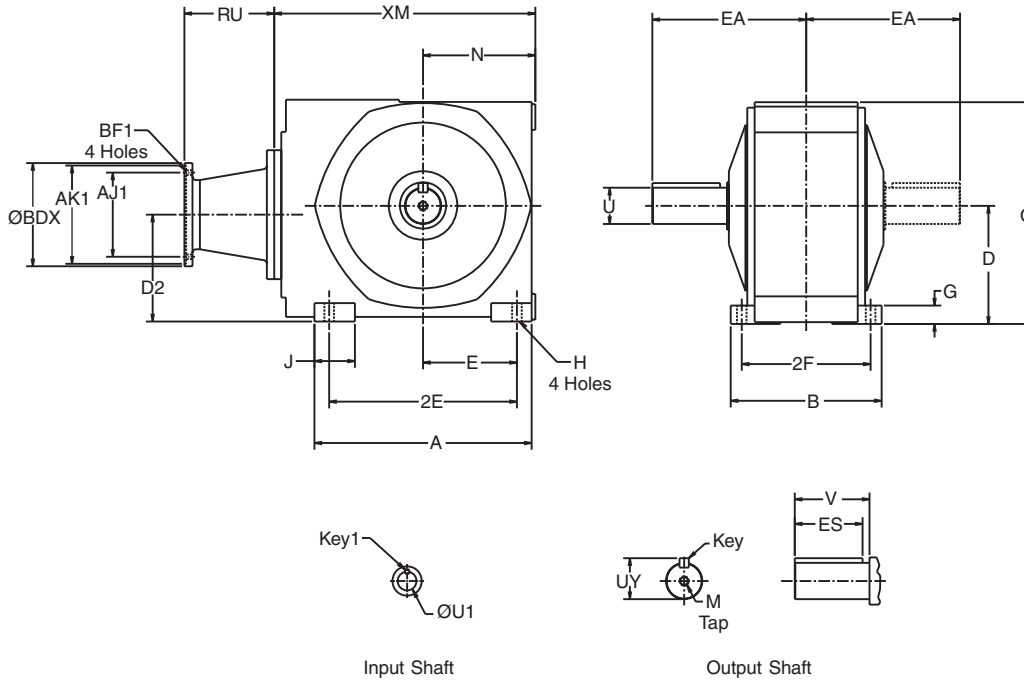

OtN Series

Gear Frame	Version	A	B	D ¹	D2	E	2E	2F	G	H	J	O	N	XM
26	S1	16.73	11.42	8.86	8.43	6.99	13.98	9.45	1.57	.87	3.54	16.65	8.74	20.15
27	S1	19.29	12.60	9.84	8.66	8.27	16.54	10.63	1.77	.94	3.94	18.50	10.04	23.00
28	S1	23.23	16.14	12.40	11.42	10.04	20.08	13.78	1.97	1.02	4.33	23.70	12.01	30.05

Output Shaft

Gear Frame	Version	U ³	UY	V	EA	Key	ES	M
26	S1	2.875	3.200	5.75	12.82	3/4 Sq.	5.13	3/4-10 X 1.97
27	S1	3.500	3.882	7.01	13.70	7/8 Sq.	6.25	1-8 X 1.97
28	S1	3.875	4.426	7.99	17.06	1.00 Sq.	7.25	1-8 X 1.97

C-Face Input

Motor Frame	Gear Frame	AJ1	AK1	BF1	U1	RU	BDX	Key1
182TC/184TC	26	7.25	8.50	.50	1.125	6.97	9.06	1/4 Sq.
	27	7.25	8.50	.50	1.125	7.95	9.06	1/4 Sq.
213TC/215TC	26	7.25	8.50	.50	1.375	6.97	9.06	5/16 Sq.
	27	7.25	8.50	.50	1.375	7.95	9.06	5/16 Sq.
254TC/256TC	28	7.25	8.50	.50	1.375	7.68	9.06	5/16 Sq.
	26	7.25	8.50	.50	1.625	6.12	9.06	3/8 Sq.
284TC/286TC	27	7.25	8.50	.50	1.625	7.95	9.06	3/8 Sq.
	28	7.25	8.50	.50	1.625	7.68	9.06	3/8 Sq.
324TC/326TC	26	9.00	10.50	.50	1.875	7.09	11.02	1/2 Sq.
	27	9.00	10.50	.50	1.875	8.66	11.02	1/2 Sq.
324TC/326TC	28	9.00	10.50	.50	1.875	8.39	11.02	1/2 Sq.
	28	11.00	12.50	.63	2.125	9.38	13.19	1/2 Sq.

¹ Dimension "D" will never be exceeded, but may vary from values shown. When exact dimensions are required, shims up to .03" may be necessary.
² All rough casting dimensions may vary by .25" due to casting variations.
³ Output shaft extension tolerances: +.0000"; -.0005" for shafts up to 1.5" diameter "U". Larger diameter "U", +.000"; -.001".

Combined Output Shafted Foot Mount OtN32 - 35

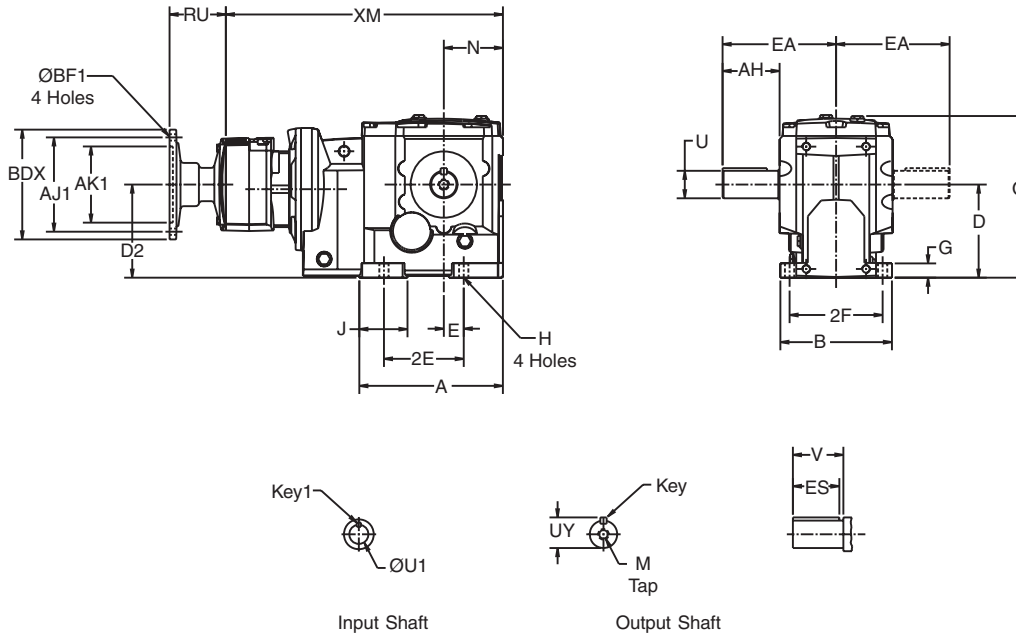

Gear Frame	Version	A	B	D ¹	D2	E	2E	2F	G	H	J	O	N	XM
32	S2	7.81	5.71	4.41	4.06	1.38	5.12	4.72	.73	.43	2.34	8.09	3.03	14.49
33,33A	S2	8.50	6.61	5.51	4.91	1.18	4.72	5.51	.85	.55	2.86	9.69	3.54	19.90 ⁴
	S1	8.08	8.58	4.92	4.87	3.35	6.69	6.10	.79	.55	2.27	10.43	3.54	
34	S2	10.13	7.87	7.09	5.57	1.57	5.91	6.50	1.07	.71	2.67	12.05	4.49	21.55
	S1	10.69	9.60	6.30	7.16	4.53	9.06	7.68	1.18	.71	3.19	13.39	4.49	
35	S2	11.92	8.66	8.35	6.56	2.17	7.09	7.09	1.18	.87	3.37	13.58	5.20	23.87
	S1	13.07	10.98	7.87	9.00	5.51	11.02	9.06	1.40	.87	4.05	16.22	5.20	

Output Shaft

Gear Frame	Version	U ³	UY	V	AH	EA	Key	ES	M
32	S2	1.250	1.354	2.36	2.46	5.31	1/4 Sq.	2.06	1/2-13 X 1.12
33,33A	S2	1.625	1.783	3.25	3.39	6.73	3/8 Sq.	2.78	5/8-11 X 1.38
	S1	1.500	1.657	3.18	3.19	7.12	3/8 Sq.	2.78	5/8-11 X 1.38
34	S2	2.000	2.210	3.63	3.76	8.11	1/2 Sq.	3.06	3/4-10 X 1.61
	S1	1.750	1.909	3.56	3.66	8.46	3/8 Sq.	3.56	3/4-10 X 1.61
35	S2	2.375	2.638	4.61	4.74	9.45	5/8 Sq.	3.81	3/4-10 X 1.61
	S1	2.375	2.638	5.73	5.27	10.57	5/8 Sq.	4.81	3/4-10 X 1.61

C-Face Input

Motor Frame	Gear Frame	AJ1	AK1	BF1	U1	RU	BDX	Key1
56C	32,33A	5.88	4.50	.38	.625	3.33	6.50	3/16 Sq.
	33,34,35	5.88	4.50	.38	.625	3.54	6.50	3/16 Sq.
143TC/145TC	32,33A	5.88	4.50	.38	.875	3.33	6.50	3/16 Sq.
	33,34,35	5.88	4.50	.38	.875	3.54	6.50	3/16 Sq.
182TC/184TC	33,34,35	7.25	8.50	.50	1.125	5.26	9.00	1/4 Sq.

¹ Dimension "D" will never be exceeded, but may vary from values shown. When exact dimensions are required, shims up to .03" may be necessary.
² All rough casting dimensions may vary by .25" due to casting variations.
³ Output shaft extension tolerances: +.0000"; -.0005" for shafts up to 1.5" diameter "U". Larger diameter "U", +.000"; -.001".
⁴ XM dimension when gear frame 33A is used will be 16.42.

Combined Output Shafted Foot Mount OtN26 - 28

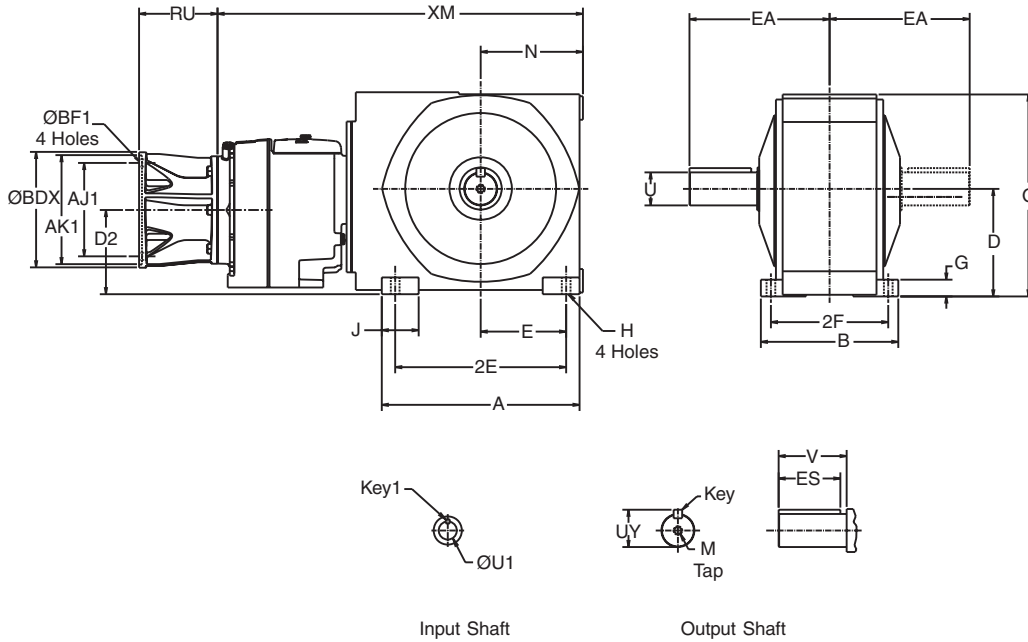

OtN Series

Gear Frame	Version	A	B	D ¹	D2	E	2E	2F	G	H	J	O	N	XM	
														56C-215TC	254TC-Up
26A	S1	16.73	11.42	8.86	7.66	6.99	13.98	9.45	1.57	.87	3.54	16.65	8.74	30.80	-
27A	S1	19.29	12.60	9.84	7.89	8.27	16.54	10.63	1.77	.94	3.94	18.50	10.04	31.47	-
28A	S1	23.23	16.14	12.40	10.40	10.04	20.08	13.78	1.97	1.02	4.33	23.70	12.01	37.14	37.49

Output Shaft

Gear Frame	Version	U ³	UY	V	EA	Key	ES	M
26A	S1	2.875	3.200	5.75	12.82	3/4 Sq.	5.13	3/4-10 X 1.97
27A	S1	3.500	3.882	7.01	13.70	7/8 Sq.	6.25	1-8 X 1.97
28A	S1	3.875	4.426	7.99	17.06	1.00 Sq.	7.25	1-8 X 1.97

C-Face Input

Motor Frame	Gear Frame	AJ1	AK1	BF1	U1	RU	BDX	Key1
56C	Any	5.88	4.50	.38	.625	3.54	6.50	3/16 Sq.
143TC/145TC	Any	5.88	4.50	.38	.875	3.54	6.50	3/16 Sq.
182TC/184TC	Any	7.25	8.50	.50	1.125	5.26	9.06	1/4 Sq.
213TC/215TC	Any	7.25	8.50	.50	1.375	5.26	9.06	5/16 Sq.
254TC/256TC	28A	7.25	8.50	.50	1.625	6.12	9.06	3/8 Sq.
284TC/286TC	28A	9.00	10.50	.50	1.875	7.09	11.02	1/2 Sq.

¹ Dimension "D" will never be exceeded, but may vary from values shown. When exact dimensions are required, shims up to .03" may be necessary.

² All rough casting dimensions may vary by .25" due to casting variations.

³ Output shaft extension tolerances: +.0000"; -.0005" for shafts up to 1.5" diameter "U". Larger diameter "U", +.000"; -.001".

3-Stage Output Shafted Flange Mount OtN32 - 35

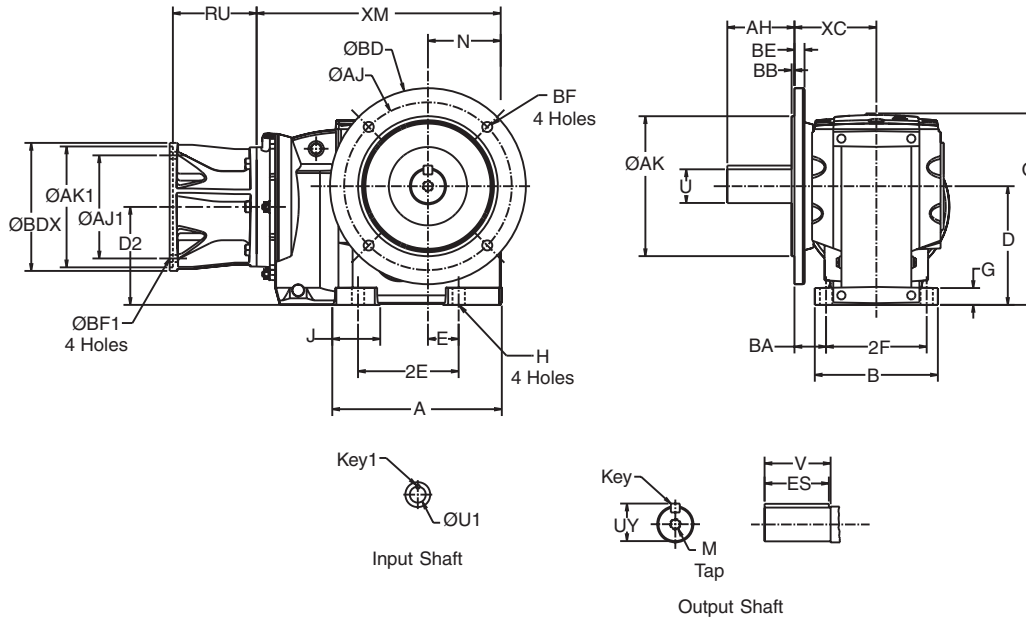

Gear Frame	Version	A	B	D ¹	D2	E	2E	2F	G	H	J	O	N	BA	XC	XM	
																56C-215TC	254TC-286TC
32	S1,S2	7.81	5.71	4.41	3.78	1.38	5.12	4.71	.73	.43	2.34	8.09	3.03	1.81	4.04	10.98	-
33	S1,S2	8.50	6.61	5.51	5.24	1.18	4.72	5.51	.85	.55	2.86	9.69	3.54	2.24	4.84	12.90	-
34	S1,S2	10.13	7.87	7.09	5.90	1.57	5.91	6.50	1.07	.71	2.67	12.05	4.49	1.93	5.18	14.56	-
35	S2	11.92	8.66	8.35	6.89	2.17	7.09	7.09	1.18	.87	3.45	13.58	5.20	2.22	5.76	16.90	17.25

Output Shaft

Gear Frame	Version	U ³	UY	V	AH	Key	ES	M
32	S2	1.250	1.354	2.38	2.36	1/4 Sq.	2.06	1/2-13 X 1.12
	S1	1.250	1.354	1.77	1.75	1/4 Sq.	1.45	1/2-13 X 1.12
33	S2	1.625	1.783	3.25	3.38	3/8 Sq.	2.78	5/8-11 X 1.38
	S1	1.500	1.657	3.18	2.28	3/8 Sq.	2.19	5/8-11 X 1.38
34	S2	2.000	2.210	3.94	3.94	1/2 Sq.	3.06	3/4-10 X 1.61
	S1	1.750	1.909	3.56	3.28	3/8 Sq.	3.56	3/4-10 X 1.61
35	S2	2.375	2.638	4.72	4.72	5/8 Sq.	3.81	3/4-10 X 1.61

Output Flange

Gear Frame	Flange Code	AK	AJ	BB	BD	BE	BF
32	5	5.118	6.50	.14	7.87	.39	.47
	6	7.087	8.46	.16	9.84	.47	.55
33	5	7.087	8.46	.16	9.84	.47	.55
	6	9.055	10.43	.16	11.81	.47	.55
34	5	9.055	10.43	.16	11.81	.59	.55
	6	9.842	11.80	.16	13.77	.59	.71
35	5	9.842	11.80	.20	13.77	.71	.71
	6	11.810	13.77	.20	15.75	.71	.71

C-Face Input

Motor Frame	Gear Frame	AJ1	AK1	BF1	U1	RU	BDX	Key1
56C	Any	5.88	4.50	.38	.625	3.54	6.50	3/16 Sq.
143TC/145TC	Any	5.88	4.50	.38	.875	3.54	6.50	3/16 Sq.
182TC/184TC	Any	7.25	8.50	.50	1.125	5.26	9.00	1/4 Sq.
213TC/215TC	33,34,35	7.25	8.50	.50	1.375	5.26	9.00	5/16 Sq.
254TC/256TC	35	7.25	8.50	.50	1.625	6.12	9.00	3/8 Sq.
284TC/286TC	35	9.00	10.50	.50	1.875	7.09	11.25	1/2 Sq.

¹ Dimension "D" will never be exceeded, but may vary from values shown. ³ Output shaft extension tolerances: +.0000"; -.0005" for shafts up to 1.5" diameter "U". Larger diameter "U", +.000"; -.001".
² All rough casting dimensions may vary by .25" due to casting variations.

3-Stage Output Shafted Flange Mount OtN26 - 28

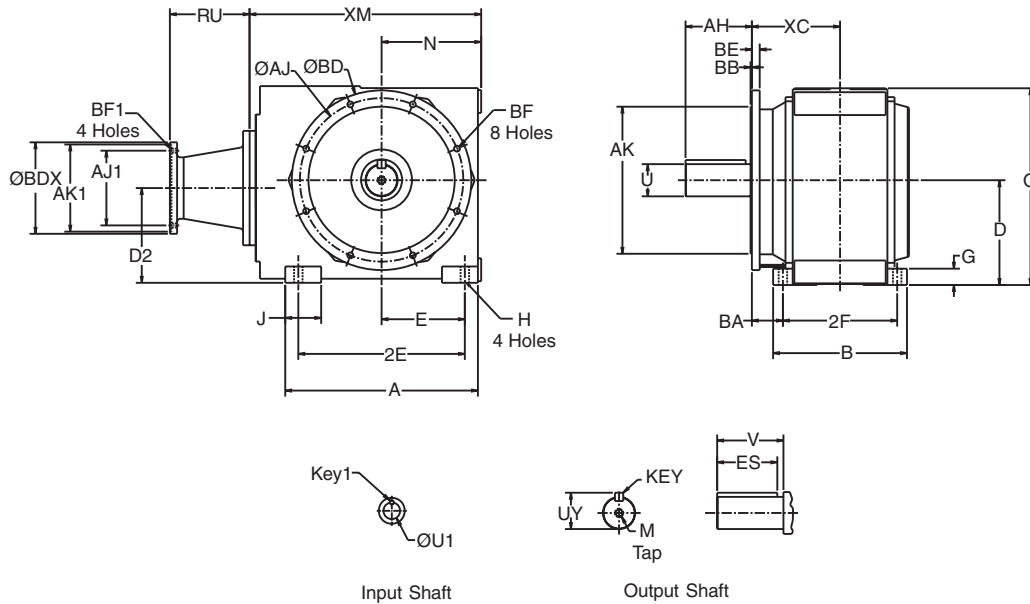

OtN Series

Gear Frame	Version	A	B	D ¹	D2	E	2E	2F	G	H	J	O	N	BA	XC	XM
26	S1	16.73	11.42	8.86	8.43	6.99	13.98	9.45	1.57	.87	3.54	16.65	8.74	3.54	9.00	20.15
27	S1	19.29	12.60	9.84	8.66	8.27	16.54	10.63	1.77	.94	3.94	18.50	10.04	3.54	8.55	23.00
28	S1	23.23	16.14	12.40	11.42	10.04	20.08	13.78	1.97	1.02	4.33	23.70	12.01	3.74	11.51	30.05

Output Shaft

Gear Frame	Version	U ³	UY	V	AH	Key	ES	M
26	S1	2.875	3.200	5.75	5.75	3/4 Sq.	5.13	3/4-10 X 1.97
27	S1	3.500	3.882	7.00	7.00	7/8 Sq.	6.25	1-8 X 1.97
28	S1	4.000	4.436	8.00	8.00	1.00 Sq.	7.25	1-8 X 1.97

Output Flange

Gear Frame	Flange Code	AJ	AK	BB	BD	BE	BF
26	5	15.75	13.75	.20	17.72	.79	.71
27	5	15.75	13.78	.20	17.72	.79	.71
28	5	19.69	17.72	.24	21.65	.94	.71

C-Face Input

Motor Frame	Gear Frame	AJ1	AK1	BF1	U1	RU	BDX	Key1
182TC/184TC	26	7.25	8.50	.50	1.125	6.97	9.06	1/4 Sq.
	27	7.25	8.50	.50	1.125	7.95	9.06	1/4 Sq.
213TC/215TC	26	7.25	8.50	.50	1.375	6.97	9.06	5/16 Sq.
	27	7.25	8.50	.50	1.375	7.95	9.06	5/16 Sq.
	28	7.25	8.50	.50	1.375	7.68	9.06	5/16 Sq.
254TC/256TC	26	7.25	8.50	.50	1.625	6.12	9.06	3/8 Sq.
	27	7.25	8.50	.50	1.625	7.95	9.06	3/8 Sq.
	28	7.25	8.50	.50	1.625	7.68	9.06	3/8 Sq.
284TC/286TC	26	9.00	10.50	.50	1.875	7.09	11.02	1/2 Sq.
	27	9.00	10.50	.50	1.875	8.66	11.02	1/2 Sq.
	28	9.00	10.50	.50	1.875	8.39	11.02	1/2 Sq.
324TC/326TC	28	11.00	12.50	.63	2.125	9.38	13.19	1/2 Sq.

¹ Dimension "D" will never be exceeded, but may vary from values shown. When exact dimensions are required, shims up to .03" may be necessary.
² All rough casting dimensions may vary by .25" due to casting variations.
³ Output shaft extension tolerances: +.0000"; -.0005" for shafts up to 1.5" diameter "U". Larger diameter "U", +.000"; -.001".

Combined Output Shafted Flange Mount OtN32 - 35

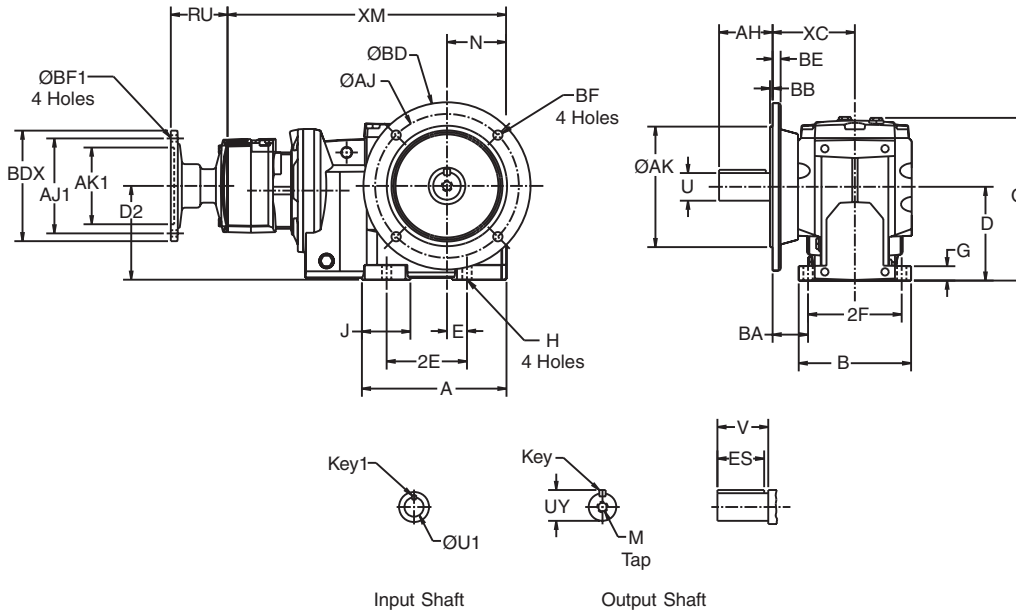

Gear Frame	Version	A	B	D ¹	D2	E	2E	2F	G	H	J	O	N	BA	XC	XM
32	S1,S2	7.81	5.71	4.41	4.06	1.38	5.12	4.71	.73	.43	2.34	8.09	3.03	1.81	4.04	14.49
33,33A	S1,S2	8.50	6.61	5.51	4.91	1.18	4.72	5.51	.85	.55	2.86	9.69	3.54	2.24	4.84	19.90 ⁴
34	S1,S2	10.13	7.87	7.09	5.57	1.57	5.91	6.50	1.07	.71	2.67	12.05	4.49	1.93	5.18	21.55
35	S2	11.92	8.66	8.35	6.56	2.17	7.09	7.09	1.18	.87	3.45	13.58	5.20	2.22	5.76	23.87

Output Shaft

Gear Frame	Version	U ³	UY	V	AH	Key	ES	M
32	S2	1.250	1.354	2.38	2.36	1/4 Sq.	2.06	1/2-13 X 1.12
	S1	1.250	1.354	1.77	1.75	1/4 Sq.	1.45	1/2-13 X 1.12
33,33A	S2	1.625	1.783	3.25	3.38	3/8 Sq.	2.78	5/8-11 X 1.38
	S1	1.500	1.657	3.18	2.28	3/8 Sq.	2.19	5/8-11 X 1.38
34	S2	2.000	2.210	3.94	3.94	1/2 Sq.	3.06	3/4-10 X 1.61
	S1	1.750	1.909	3.56	3.28	3/8 Sq.	3.56	3/4-10 X 1.61
35	S2	2.375	2.638	4.72	4.72	5/8 Sq.	3.81	3/4-10 X 1.61

Output Flange

Gear Frame	Flange Code	AK	AJ	BB	BD	BE	BF
32	5	5.118	6.50	.14	7.87	.39	.47
	6	7.087	8.46	.16	9.84	.47	.55
33,33A	5	7.087	8.46	.16	9.84	.47	.55
	6	9.055	10.43	.16	11.81	.47	.55
34	5	9.055	10.43	.16	11.81	.59	.55
	6	9.842	11.80	.16	13.77	.59	.71
35	5	9.842	11.80	.20	13.77	.71	.71
	6	11.810	13.77	.20	15.75	.71	.71

C-Face Input

Motor Frame	Gear Frame	AJ1	AK1	BF1	U1	RU	BDX	Key1
56C	32,33A	5.88	4.50	.38	.625	3.33	6.50	3/16 Sq.
	33,34,35	5.88	4.50	.38	.625	3.54	6.50	3/16 Sq.
143TC/145TC	32,33A	5.88	4.50	.38	.875	3.33	6.50	3/16 Sq.
	33,34,35	5.88	4.50	.38	.875	3.54	6.50	3/16 Sq.
182TC/184TC	33,34,35	7.25	8.50	.50	1.125	5.26	9.00	1/4 Sq.

¹ Dimension "D" will never be exceeded, but may vary from values shown. When exact dimensions are required, shims up to .03" may be necessary. ³ Output shaft extension tolerances: +.0000"; -.0005" for shafts up to 1.5" diameter "U". Larger diameter "U", +.000"; -.001".
² All rough casting dimensions may vary by .25" due to casting variations. ⁴ XM dimension when gear frame 33A is used will be 16.42.

Combined Output Shafted Flange Mount OtN26 - 28

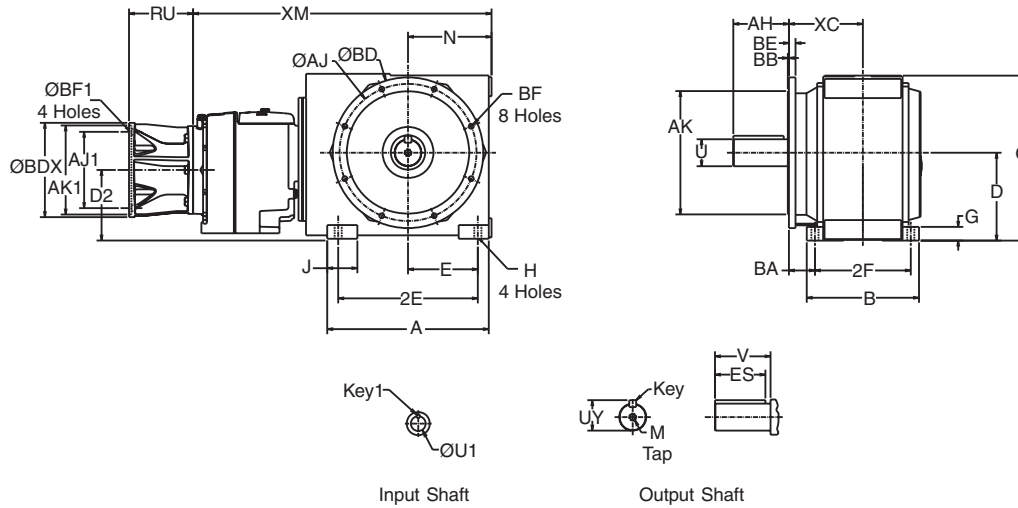

OtN Series

Gear Frame	Version	A	B	D ¹	D2	E	2E	2F	G	H	J	O	N	BA	XC	XM	
																56C-215TC	254TC-Up
26A	S1	16.73	11.42	8.86	7.66	6.99	13.98	9.45	1.57	.87	3.54	16.65	8.74	3.54	9.00	30.80	-
27A	S1	19.29	12.60	9.84	7.89	8.27	16.54	10.63	1.77	.94	3.94	18.50	10.04	3.54	8.55	31.47	-
28A	S1	23.23	16.14	12.40	10.40	10.04	20.08	13.78	1.97	1.02	4.33	23.70	12.01	3.74	11.51	37.14	37.49

Output Shaft

Gear Frame	Version	U ³	UY	V	AH	Key	ES	M
26A	S1	2.875	3.200	5.75	5.75	3/4 Sq.	5.13	3/4-10 X 1.97
27A	S1	3.500	3.882	7.00	7.00	7/8 Sq.	6.25	1-8 X 1.97
28A	S1	4.000	4.436	8.00	8.00	1.00 Sq.	7.25	1-8 X 1.97

Output Flange

Gear Frame	Flange Code	AJ	AK	BB	BD	BE	BF
26A	5	15.75	13.75	.20	17.72	.79	.71
27A	5	15.75	13.78	.20	17.72	.79	.71
28A	5	19.69	17.72	.24	21.65	.94	.71

C-Face Input

Motor Frame	Gear Frame	AJ1	AK1	BF1	U1	RU	BDX	Key1
56C	Any	5.88	4.50	.38	.625	3.54	6.50	3/16 Sq.
143TC/145TC	Any	5.88	4.50	.38	.875	3.54	6.50	3/16 Sq.
182TC/184TC	Any	7.25	8.50	.50	1.125	5.26	9.06	1/4 Sq.
213TC/215TC	Any	7.25	8.50	.50	1.375	5.26	9.06	5/16 Sq.
254TC/256TC	28A	7.25	8.50	.50	1.625	6.12	9.06	3/8 Sq.
284TC/286TC	28A	9.00	10.50	.50	1.875	7.09	11.02	1/2 Sq.

¹ Dimension "D" will never be exceeded, but may vary from values shown. When exact dimensions are required, shims up to .03" may be necessary.
² All rough casting dimensions may vary by .25" due to casting variations.
³ Output shaft extension tolerances: +.0000"; -.0005" for shafts up to 1.5" diameter "U". Larger diameter "U", +.000"; -.001".

3-Stage Finished Bore Hollow Shaft OtN32 - 35

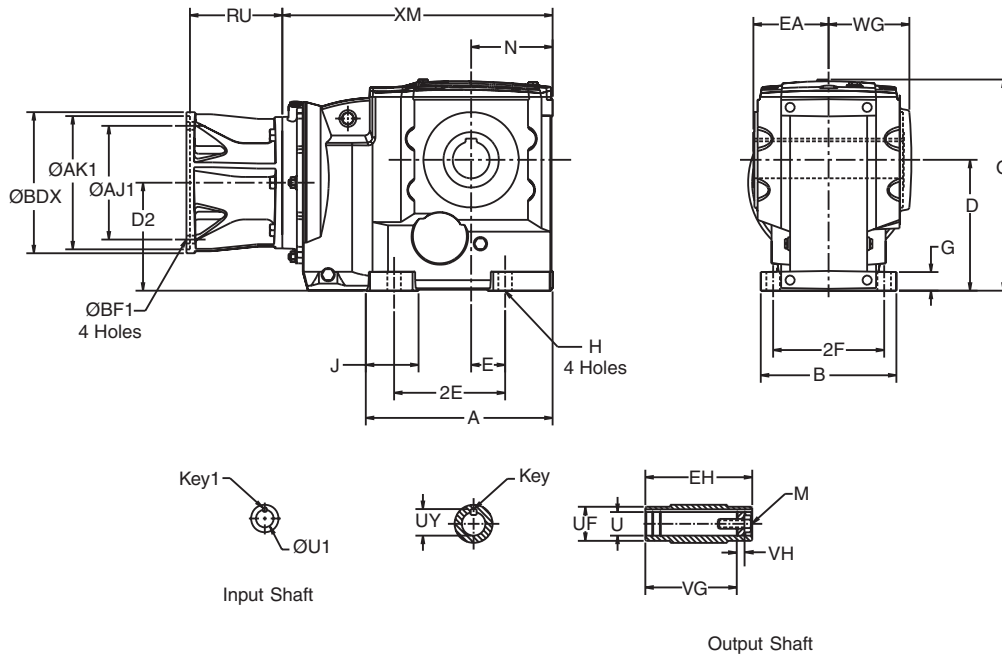

Gear Frame	Version	A	B	D ¹	D2	E	2E	2F	G	H	J	O	N	WG	XM	
															56C-215TC	254TC-286TC
32	S2	7.81	5.71	4.41	3.78	1.38	5.12	4.71	.73	.43	2.34	8.09	3.03	3.22	10.98	-
33	S2	8.50	6.61	5.51	5.24	1.18	4.72	5.51	.85	.55	2.86	9.69	3.54	3.73	12.90	-
34	S2	10.13	7.87	7.09	5.90	1.57	5.91	6.50	1.07	.71	2.67	12.05	4.49	4.66	14.56	-
35	S2	11.92	8.66	8.35	6.89	2.17	7.09	7.09	1.18	.87	3.45	13.58	5.20	5.15	16.90	17.25

Output Shaft

Gear Frame	Version	EA	EH	U ^{6,7}	UF	UY	VG	VH	Key ⁴	M
32	S2	2.98	5.95	1.375	1.96	1.523	5.20	.55	5/16 X 5/16 X 1 13/16	1/2-13 X 1.00
33	S2	3.47	6.94	1.500	2.16	1.674	5.96	.55	3/8 X 3/8 X 2 1/4	5/8-11 X 1.75
34	S2	4.49	8.97	2.000	2.56	2.210	7.44	.79	1/2 X 7/16 X 2 5/8	5/8-11 X 1.75
35	S2	4.83	9.66	2.375	3.54	2.656	8.15	.94	5/8 X 5/8 X 3 5/8	3/4-10 X 2.00

C-Face Input

Motor Frame	Gear Frame	AJ1	AK1	BF1	U1	RU	BDX	Key1
56C	Any	5.88	4.50	.38	.625	3.54	6.50	3/16 Sq.
143TC/145TC	Any	5.88	4.50	.38	.875	3.54	6.50	3/16 Sq.
182TC/184TC	Any	7.25	8.50	.50	1.125	5.26	9.00	1/4 Sq.
213TC/215TC	33,34,35	7.25	8.50	.50	1.375	5.26	9.00	5/16 Sq.
254TC/256TC	35	7.25	8.50	.50	1.625	6.12	9.00	3/8 Sq.
284TC/286TC	35	9.00	10.50	.50	1.875	7.09	11.25	1/2 Sq.

¹ Dimension "D" will never be exceeded, but may vary from values shown. When exact dimensions are required, shims up to .03" may be necessary.
² All rough casting dimensions may vary by .25" due to casting variations.
³ Driven shaft entry can be from either side of the gear reducer housing by reversing positioning of the snap rings and washer illustrated.
⁴ Output key supplied only on frame 34 in "S2" version.
⁵ For details of the torque arm kit, refer to page B-114.
⁶ Output bore tolerances: +.0020", -.0000" for all diameters.
⁷ Refer to page B-116 by gear frame for Tapered Bushed designs if driven shaft varies from "U" dimensions offered above.

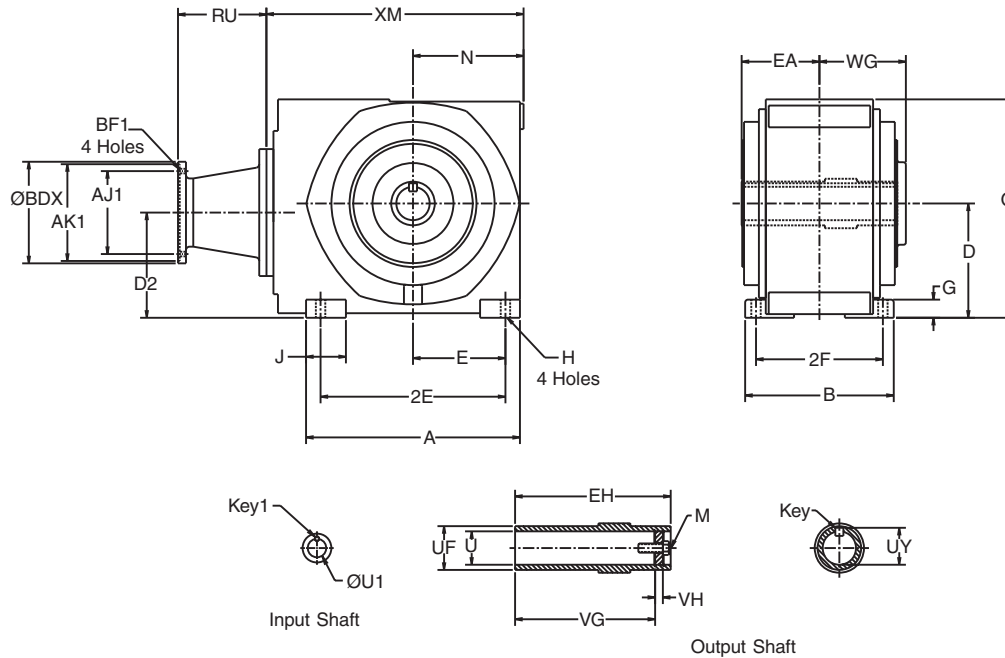

Gear Frame	Version	A	B	D ¹	D2	E	2E	2F	G	H	J	O	N	WG	XM
26	S1	16.73	11.42	8.86	8.43	6.99	13.98	9.45	1.57	.87	3.54	16.65	8.74	6.97	20.15
27	S1	19.29	12.60	9.84	8.66	8.27	16.54	10.63	1.77	.94	3.94	18.50	10.04	7.72	23.00
28	S1	23.23	16.14	12.40	11.42	10.04	20.08	13.78	1.97	1.02	4.33	23.70	12.01	9.49	30.05

Output Shaft

Gear Frame	Version	EA	EH	U ⁵	UF	UY	VG	VH	Key	M
26	S1	6.10	12.20	2.750	3.35	3.027	10.25	.91	5/8 Sq.	3/4-10
27	S1	6.70	13.40	3.125	3.75	3.454	11.40	.91	3/4 Sq.	3/4-10
28	S1	8.45	16.90	3.625	4.35	4.009	14.95	1.02	7/8 Sq.	1-8

C-Face Input

Motor Frame	Gear Frame	AJ1	AK1	BF1	U1	RU	BDX	Key1
182TC/184TC	26	7.25	8.50	.50	1.125	6.97	9.06	1/4 Sq.
	27	7.25	8.50	.50	1.125	7.95	9.06	1/4 Sq.
213TC/215TC	26	7.25	8.50	.50	1.375	6.97	9.06	5/16 Sq.
	27	7.25	8.50	.50	1.375	7.95	9.06	5/16 Sq.
	28	7.25	8.50	.50	1.375	7.68	9.06	5/16 Sq.
254TC/256TC	26	7.25	8.50	.50	1.625	6.12	9.06	3/8 Sq.
	27	7.25	8.50	.50	1.625	7.95	9.06	3/8 Sq.
	28	7.25	8.50	.50	1.625	7.68	9.06	3/8 Sq.
284TC/286TC	26	9.00	10.50	.50	1.875	7.09	11.02	1/2 Sq.
	27	9.00	10.50	.50	1.875	8.66	11.02	1/2 Sq.
	28	9.00	10.50	.50	1.875	8.39	11.02	1/2 Sq.
324TC/326TC	28	11.00	12.50	.63	2.125	9.38	13.19	1/2 Sq.

¹ Dimension "D" will never be exceeded, but may vary from values shown. When exact dimensions are required, shims up to .03" may be necessary.
² All rough casting dimensions may vary by .25" due to casting variations.
³ Driven shaft entry can be from either side of the gear reducer housing by reversing positioning of the snap rings and washer illustrated.
⁴ For details of the torque arm kit, refer to page B-115.
⁵ Output bore tolerances: +.0020", -.0000" for all diameters.

Combined Finished Bore Hollow Shaft OtN32 - 35

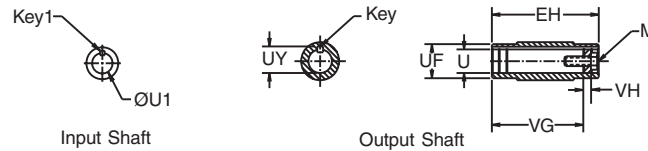
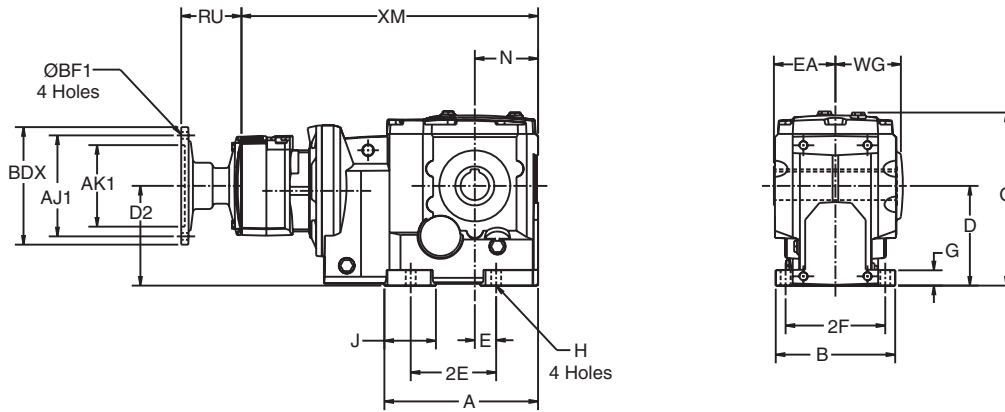

Gear Frame	Version	A	B	D'	D2	E	2E	2F	G	H	J	O	N	WG	XM
32	S2	7.81	5.71	4.41	4.06	1.38	5.12	4.71	.73	.43	2.34	8.09	3.03	3.22	14.49
33,33A	S2	8.50	6.61	5.51	4.91	1.18	4.72	5.51	.85	.55	2.86	9.69	3.54	3.73	19.90 ⁸
34	S2	10.13	7.87	7.09	5.57	1.57	5.91	6.50	1.07	.71	2.67	12.05	4.49	4.66	21.55
35	S2	11.92	8.66	8.35	6.56	2.17	7.09	7.09	1.18	.87	3.45	13.58	5.20	5.15	23.87

Output Shaft

Gear Frame	Version	EA	EH	U ^{3,7}	UF	UY	VG	VH	Key ⁵	M
32	S2	2.98	5.95	1.375	1.96	1.523	5.20	.55	5/16 X 5/16 X 1 13/16	1/2-13 X 1.00
33,33A	S2	3.47	6.94	1.500	2.16	1.674	5.96	.55	3/8 X 3/8 X 2 1/4	5/8-11 X 1.75
34	S2	4.49	8.97	2.000	2.56	2.210	7.44	.79	1/2 X 7/16 X 2 5/8	5/8-11 X 1.75
35	S2	4.83	9.66	2.375	3.54	2.656	8.15	.94	5/8 X 5/8 X 3 5/8	3/4-10 X 2.00

C-Face Input

Motor Frame	Gear Frame	AJ1	AK1	BF1	U1	RU	BDX	Key1
56C	32,33A	5.88	4.50	.38	.625	3.33	6.50	3/16 Sq.
	33,34,35	5.88	4.50	.38	.625	3.54	6.50	3/16 Sq.
143TC/145TC	32,33A	5.88	4.50	.38	.875	3.33	6.50	3/16 Sq.
	33,34,35	5.88	4.50	.38	.875	3.54	6.50	3/16 Sq.
182TC/184TC	33,34,35	7.25	8.50	.50	1.125	5.26	9.00	1/4 Sq.

¹ Dimension "D" will never be exceeded, but may vary from values shown. When exact dimensions are required, shims up to .03" may be necessary.
² All rough casting dimensions may vary by .25" due to casting variations.
³ Refer to page B-116 by gear frame for Tapered Bushed designs if driven shaft varies from "U" dimension offered above.
⁴ Driven shaft entry can be from either side of the gear reducer housing by reversing positioning of the snap rings and washer illustrated.
⁵ Output key supplied only on frame 34 in "S2" version.
⁶ For details of the torque arm kit, refer to page B-114.
⁷ Output bore tolerances: +.0020", -.0000" for all diameters.
⁸ XM dimension when gear frame 33A is used will be 16.42.

Combined Finished Bore Hollow Shaft OtN26 - 28

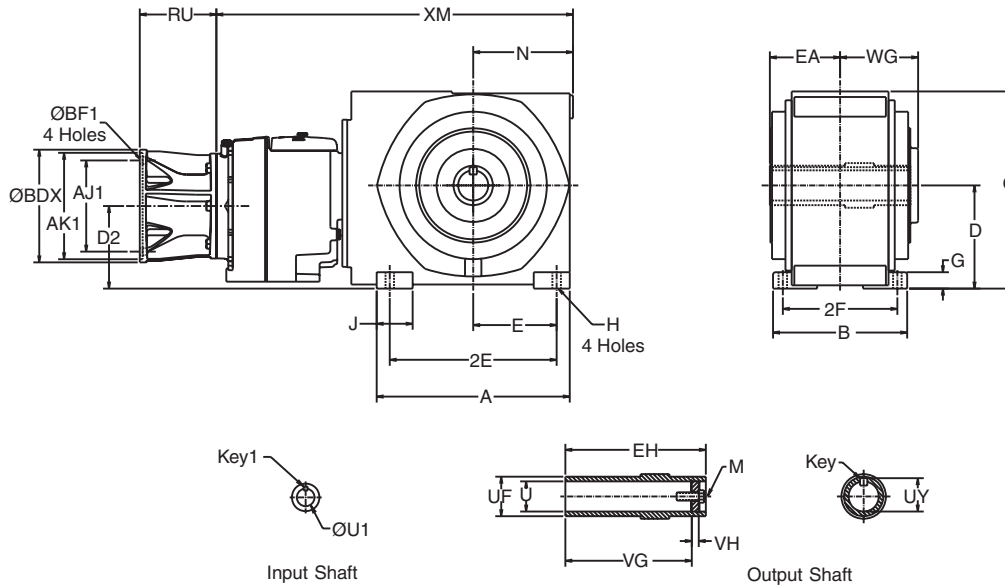

OtN Series

Gear Frame	Version	A	B	D ¹	D2	E	2E	2F	G	H	J	O	N	WG	XM	
															56C-215TC	254TC-Up
26A	S1	16.73	11.42	8.86	7.66	6.99	13.98	9.45	1.57	.87	3.54	16.65	8.74	6.97	30.80	-
27A	S1	19.29	12.60	9.84	7.89	8.27	16.54	10.63	1.77	.94	3.94	18.50	10.04	7.72	31.47	-
28A	S1	23.23	16.14	12.40	10.40	10.04	20.08	13.78	1.97	1.02	4.33	23.70	12.01	9.49	37.14	37.49

Output Shaft

Gear Frame	Version	EA	EH	U ⁴	UF	UY	VG	VH	Key	M
26A	S1	6.10	12.20	2.750	3.35	3.027	10.25	.91	5/8 Sq.	3/4-10
27A	S1	6.70	13.40	3.125	3.75	3.454	11.40	.91	3/4 Sq.	3/4-10
28A	S1	8.45	16.90	3.625	4.35	4.009	14.95	1.02	7/8 Sq.	1-8

C-Face Input

Motor Frame	Gear Frame	AJ1	AK1	BF1	U1	RU	BDX	Key1
56C	Any	5.88	4.50	.38	.625	3.54	6.50	3/16 Sq.
143TC/145TC	Any	5.88	4.50	.38	.875	3.54	6.50	3/16 Sq.
182TC/184TC	Any	7.25	8.50	.50	1.125	5.26	9.06	1/4 Sq.
213TC/215TC	Any	7.25	8.50	.50	1.375	5.26	9.06	5/16 Sq.
254TC/256TC	28A	7.25	8.50	.50	1.625	6.12	9.06	3/8 Sq.
284TC/286TC	28A	9.00	10.50	.50	1.875	7.09	11.02	1/2 Sq.

¹ Dimension "D" will never be exceeded, but may vary from values shown. ⁴ For details of the torque arm kit, refer to page B-115.
² All rough casting dimensions may vary by .25" due to casting variations. ⁵ Output bore tolerances: +.0020", -.0000" for all diameters.
³ Driven shaft entry can be from either side of the gear reducer housing by reversing positioning of the snap rings and washer illustrated.

3-Stage Finished Bore Hollow Shaft Face Mount OtN32 - 35

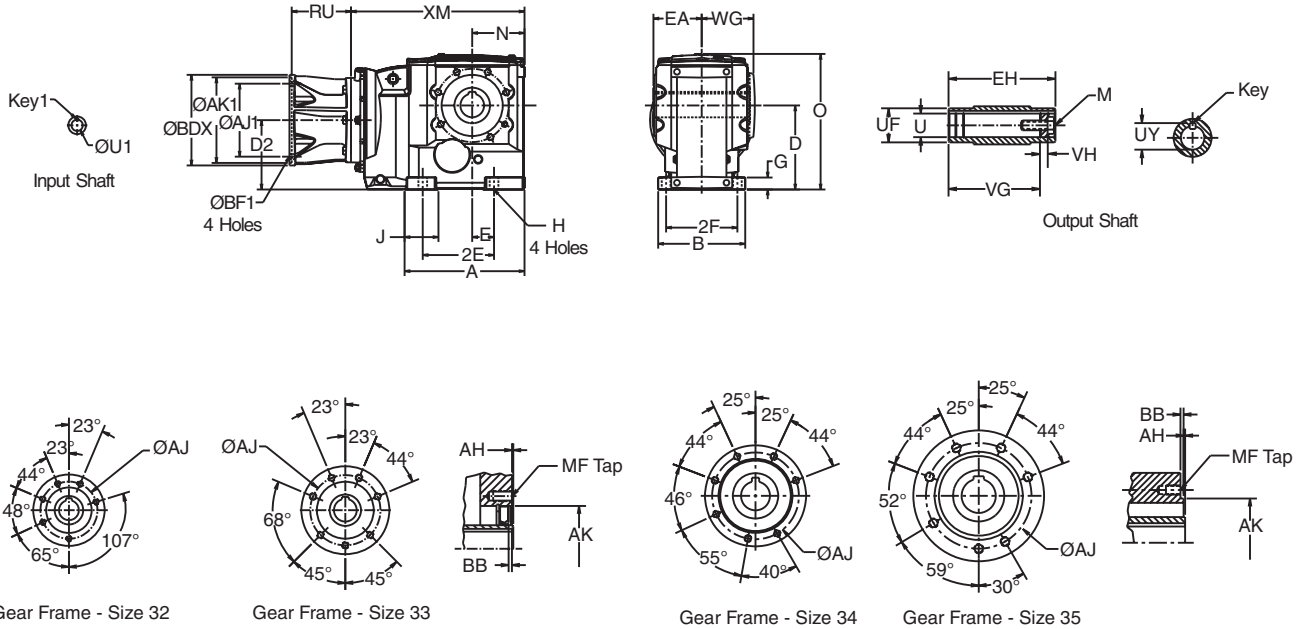

Gear Frame	Version	A	B	D ¹	D2	E	2E	2F	G	H	J	O	N	WG	XM	
															56C-215TC	254TC-286TC
32	S2	7.81	5.71	4.41	3.78	1.38	5.12	4.71	.73	.43	2.34	8.09	3.03	3.15	10.98	-
33	S2	8.50	6.61	5.51	5.24	1.18	4.72	5.51	.85	.55	2.86	9.69	3.54	3.63	12.90	-
34	S2	10.13	7.87	7.09	5.90	1.57	5.91	6.50	1.07	.71	2.67	12.05	4.49	4.66	14.56	-
35	S2	11.92	8.66	8.35	6.89	2.17	7.09	7.09	1.18	.87	3.45	13.58	5.20	5.15	16.90	17.25

Output Shaft

Gear Frame	Version	EA	EH	U ⁴	UF	UY	VG	VH	Key ⁵	M
32	S2	2.98	5.95	1.375	1.96	1.523	5.20	.55	5/16 X 5/16 X 1 13/16	1/2-13 X 1.00
33	S2	3.47	6.94	1.500	2.16	1.674	5.96	.55	3/8 X 3/8 X 2 1/4	5/8-11 X 1.75
34	S2	4.49	8.97	2.000	2.56	2.210	7.44	.79	1/2 X 7/16 X 2 5/8	5/8-11 X 1.75
35	S2	4.83	9.66	2.375	3.54	2.656	8.15	.94	5/8 X 5/8 X 3 5/8	3/4-10 X 2.00

Face Mount

Gear Frame	Version	AH	AJ	AK	BB	MF
32	S2	.12	3.94	3.15	.16	M10 X .87
33	S2	.12	4.84	3.94	.16	M12 X .87
34	S2	.14	5.98	5.12	.28	M10 X .87
35	S2	.13	7.48	6.10	.28	M12 X .87

C-Face Input

Motor Frame	Gear Frame	AJ1	AK1	BF1	U1	RU	BDX	Key1
56C	Any	5.88	4.50	.38	.625	3.54	6.50	3/16 Sq.
143TC/145TC	Any	5.88	4.50	.38	.875	3.54	6.50	3/16 Sq.
182TC/184TC	Any	7.25	8.50	.50	1.125	5.26	9.00	1/4 Sq.
213TC/215TC	33,34,35	7.25	8.50	.50	1.375	5.26	9.00	5/16 Sq.
254TC/256TC	35	7.25	8.50	.50	1.625	6.12	9.00	3/8 Sq.
284TC/286TC	35	9.00	10.50	.50	1.875	7.09	11.25	1/2 Sq.

¹ Dimension "D" will never be exceeded, but may vary from values shown. ⁴ Output bore tolerances: +.0020", -.0000" for all diameters.
² All rough casting dimensions may vary by .25" due to casting variations. ⁵ Output key supplied only on frame 34 in "S2" version.
³ Driven shaft entry can be from either side of the gear reducer housing by reversing positioning of the snap rings and washer illustrated.

3-Stage Finished Bore Hollow Shaft Face Mount OtN26 - 28

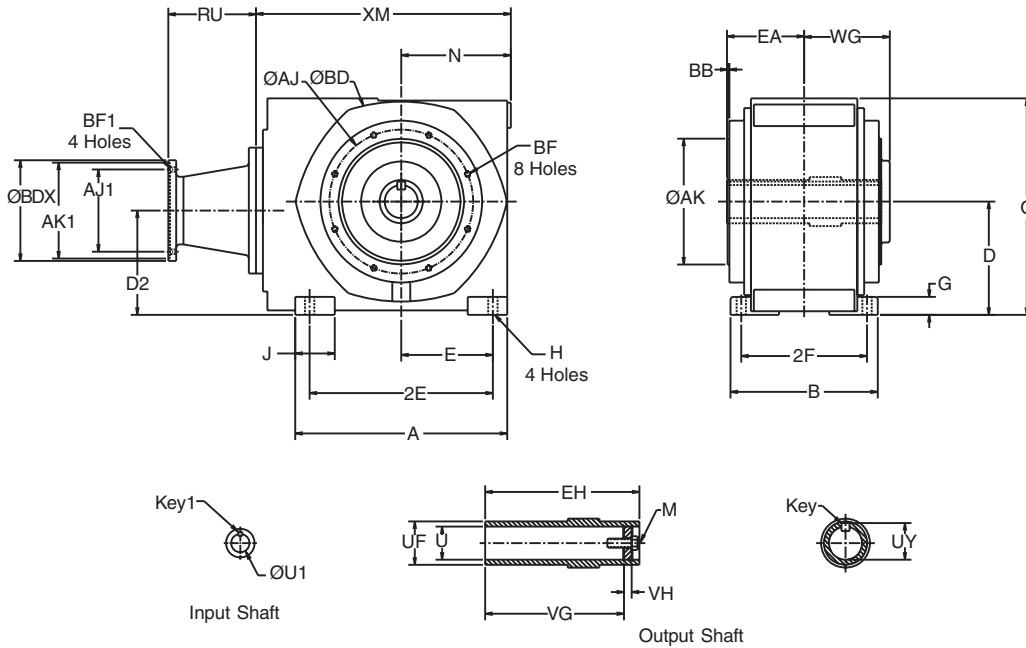

OtN Series

Gear Frame	Version	A	B	D'	D2	E	2E	2F	G	H	J	O	N	WG	XM
26	S1	16.73	11.42	8.86	8.43	6.99	13.98	9.45	1.57	.87	3.54	16.65	8.74	6.97	20.15
27	S1	19.29	12.60	9.84	8.66	8.27	16.54	10.63	1.77	.94	3.94	18.50	10.04	7.72	23.00
28	S1	23.23	16.14	12.40	11.42	10.04	20.08	13.78	1.97	1.02	4.33	23.70	12.01	9.49	30.05

Output Shaft

Gear Frame	Version	EA	EH	U ⁴	UF	UY	VG	VH	Key	M
26	S1	6.10	12.20	2.750	3.35	3.027	10.25	.91	5/8 Sq.	3/4-10
27	S1	6.70	13.40	3.125	3.75	3.454	11.40	.91	3/4 Sq.	3/4-10
28	S1	8.45	16.90	3.625	4.35	4.009	14.95	1.02	7/8 Sq.	1-8

Face Mount

Gear Frame	Version	AJ	AK	BB	BD	BF
26	S1	11.81	9.84	.20	13.78	M16 X 22
27	S1	13.78	11.81	.20	15.75	M16 X 22
28	S1	15.75	13.78	.20	17.72	M16 X 22

C-Face Input

Motor Frame	Gear Frame	AJ1	AK1	BF1	U1	RU	BDX	Key1
182TC/184TC	26	7.25	8.50	.50	1.125	6.97	9.06	1/4 Sq.
	27	7.25	8.50	.50	1.125	7.95	9.06	1/4 Sq.
213TC/215TC	26	7.25	8.50	.50	1.375	6.97	9.06	5/16 Sq.
	27	7.25	8.50	.50	1.375	7.95	9.06	5/16 Sq.
254TC/256TC	26	7.25	8.50	.50	1.625	6.12	9.06	3/8 Sq.
	27	7.25	8.50	.50	1.625	7.95	9.06	3/8 Sq.
284TC/286TC	26	9.00	10.50	.50	1.875	7.09	11.02	1/2 Sq.
	27	9.00	10.50	.50	1.875	8.66	11.02	1/2 Sq.
324TC/326TC	26	9.00	10.50	.50	1.875	8.39	11.02	1/2 Sq.
	28	11.00	12.50	.63	2.125	9.38	13.19	1/2 Sq.

¹ Dimension "D" will never be exceeded, but may vary from values shown. When exact dimensions are required, shims up to .03" may be necessary. ² All rough casting dimensions may vary by .25" due to casting variations. ³ Driven shaft entry can be from either side of the gear reducer housing by reversing positioning of the snap rings and washer illustrated. ⁴ Output bore tolerances: +.0020", -.0000" for all diameters.

Combined Finished Bore Hollow Shaft Face Mount OtN32 - 35

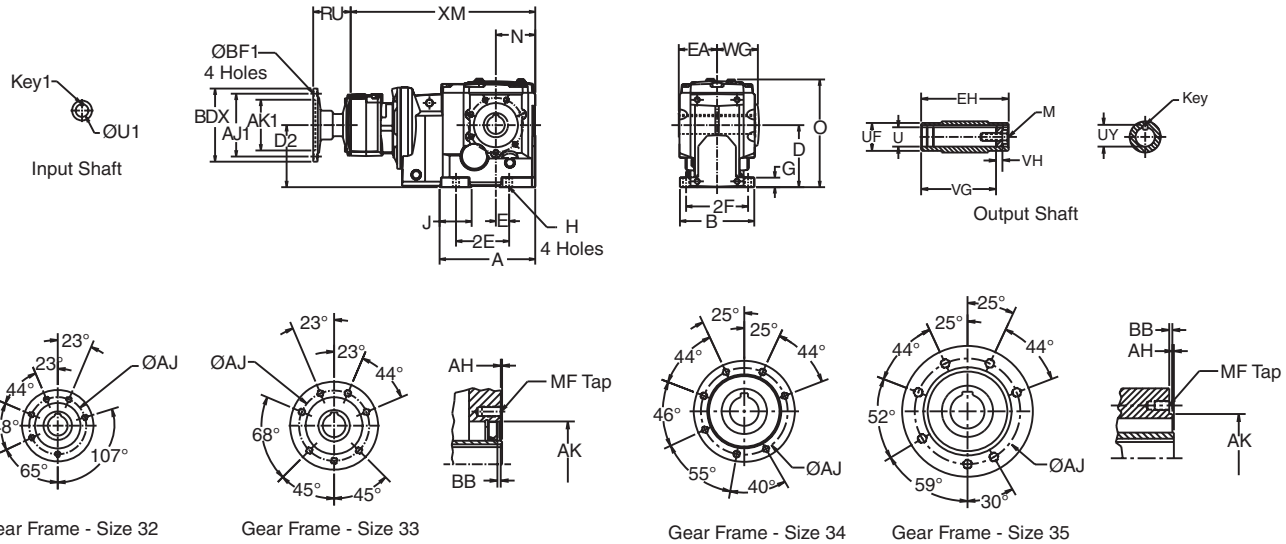

Gear Frame	Version	A	B	D ¹	D2	E	2E	2F	G	H	J	O	N	WG	XM
32	S2	7.81	5.71	4.41	4.06	1.38	5.12	4.71	.73	.43	2.34	8.09	3.03	3.15	14.49
33,33A	S2	8.50	6.61	5.51	4.91	1.18	4.72	5.51	.85	.55	2.86	9.69	3.54	3.63	19.90 ³
34	S2	10.13	7.87	7.09	5.57	1.57	5.91	6.50	1.07	.71	2.67	12.05	4.49	4.66	21.55
35	S2	11.92	8.66	8.35	6.56	2.17	7.09	7.09	1.18	.87	3.45	13.58	5.20	5.15	23.87

Output Shaft

Gear Frame	Version	EA	EH	U ⁵	UF	UY	VG	VH	Key ⁶	M
32	S2	2.98	5.95	1.375	1.96	1.523	5.20	.55	5/16 X 5/16 X 1 13/16	1/2-13 X 1.00
33,33A	S2	3.47	6.94	1.500	2.16	1.674	5.96	.55	3/8 X 3/8 X 2 1/4	5/8-11 X 1.75
34	S2	4.49	8.97	2.000	2.56	2.210	7.44	.79	1/2 X 7/16 X 2 5/8	5/8-11 X 1.75
35	S2	4.83	9.66	2.375	3.54	2.656	8.15	.94	5/8 X 5/8 X 3 5/8	3/4-10 X 2.00

Face Mount

Gear Frame	Version	AH	AJ	AK	BB	MF
32	S2	.12	3.94	3.15	.16	M10 X .87
33,33A	S2	.12	4.84	3.94	.16	M12 X .87
34	S2	.14	5.98	5.12	.28	M10 X .87
35	S2	.13	7.48	6.10	.28	M12 X .87

C-Face Input

Motor Frame	Gear Frame	AJ1	AK1	BF1	U1	RU	BDX	Key1
56C	32,33A	5.88	4.50	.38	.625	3.33	6.50	3/16 Sq.
	33,34,35	5.88	4.50	.38	.625	3.54	6.50	3/16 Sq.
143TC/145TC	32,33A	5.88	4.50	.38	.875	3.33	6.50	3/16 Sq.
	33,34,35	5.88	4.50	.38	.875	3.54	6.50	3/16 Sq.
182TC/184TC	33,34,35	7.25	8.50	.50	1.125	5.26	9.00	1/4 Sq.

¹ Dimension "D" will never be exceeded, but may vary from values shown. When exact dimensions are required, shims up to .03" may be necessary.

² All rough casting dimensions may vary by .25" due to casting variations.

³ XM dimension when gear frame 33A is used will be 16.42.

⁴ Driven shaft entry can be from either side of the gear reducer housing by reversing positioning of the snap rings and washer illustrated.

⁵ Output bore tolerances: +.0020", -.0000" for all diameters.

⁶ Output key supplied only on frame 34 in "S2" version.

Combined Finished Bore Hollow Shaft Face Mount OtN26 - 28

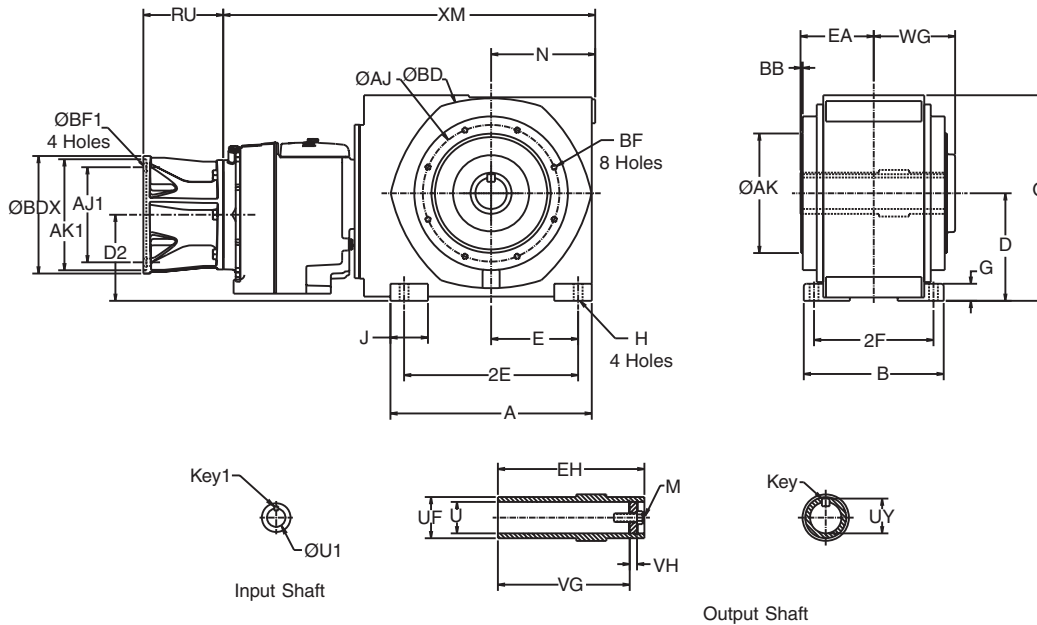

OtN Series

Gear Frame	Version	A	B	D ¹	D2	E	2E	2F	G	H	J	O	N	WG	XM	
															56C-215TC	254TC-UP
26A	S1	16.73	11.42	8.86	7.66	6.99	13.98	9.45	1.57	.87	3.54	16.65	8.74	6.97	30.80	-
27A	S1	19.29	12.60	9.84	7.89	8.27	16.54	10.63	1.77	.94	3.94	18.50	10.04	7.72	31.47	-
28A	S1	23.23	16.14	12.40	10.40	10.04	20.08	13.78	1.97	1.02	4.33	23.70	12.01	9.49	37.14	37.49

Output Shaft

Gear Frame	Version	EA	EH	U ⁴	UF	UY	VG	VH	Key	M
26A	S1	6.10	12.20	2.750	3.35	3.027	10.25	.91	5/8 Sq.	3/4-10
27A	S1	6.70	13.40	3.125	3.75	3.454	11.40	.91	3/4 Sq.	3/4-10
28A	S1	8.45	16.90	3.625	4.35	4.009	14.95	1.02	7/8 Sq.	1-8

Face Mount

Gear Frame	Version	AJ	AK	BB	BD	BF
26A	S1	11.81	9.84	.20	13.78	M16 X 22
27A	S1	13.78	11.81	.20	15.75	M16 X 22
28A	S1	15.75	13.78	.20	17.72	M16 X 22

C-Face Input

Motor Frame	Gear Frame	AJ1	AK1	BF1	U1	RU	BDX	Key1
56C	Any	5.88	4.50	.38	.625	3.54	6.50	3/16 Sq.
143TC/145TC	Any	5.88	4.50	.38	.875	3.54	6.50	3/16 Sq.
182TC/184TC	Any	7.25	8.50	.50	1.125	5.26	9.06	1/4 Sq.
213TC/215TC	Any	7.25	8.50	.50	1.375	5.26	9.06	5/16 Sq.
254TC/256TC	28A	7.25	8.50	.50	1.625	6.12	9.06	3/8 Sq.
284TC/286TC	28A	9.00	10.50	.50	1.875	7.09	11.02	1/2 Sq.

¹ Dimension "D" will never be exceeded, but may vary from values shown. When exact dimensions are required, shims up to .03" may be necessary. ³ Driven shaft entry can be from either side of the gear reducer housing by reversing positioning of the snap rings and washer illustrated. ² All rough casting dimensions may vary by .25" due to casting variations. ⁴ Output bore tolerances: +.0020", -.0000" for all diameters.

3-Stage Finished Bore Hollow Shaft Flange Mount OtN32 - 35

OtN Series

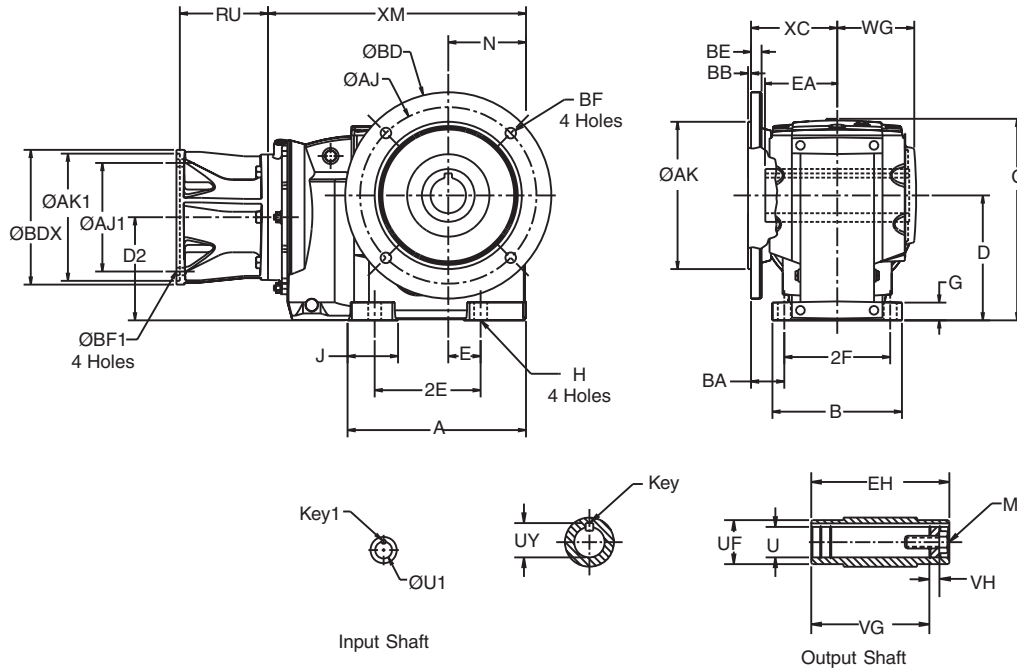

Gear Frame	Version	A	B	D ¹	D2	E	2E	2F	G	H	J	O	N	BA	WG	XC	XM	
																	56C-215TC	254TC-286TC
32	S2	7.81	5.71	4.41	3.78	1.38	5.12	4.71	.73	.43	2.34	8.09	3.03	1.81	3.22	4.04	10.98	-
33	S2	8.50	6.61	5.51	5.24	1.18	4.72	5.51	.85	.55	2.86	9.69	3.54	2.08	3.73	4.84	12.90	-
34	S2	10.13	7.87	7.09	5.90	1.57	5.91	6.50	1.07	.71	2.67	12.05	4.49	1.93	4.66	5.18	14.56	-
35	S2	11.92	8.66	8.35	6.89	2.17	7.09	7.09	1.18	.87	3.45	13.58	5.20	2.22	5.15	5.77	16.90	17.25

Output Shaft

Gear Frame	Version	EA	EH	U ⁵	UF	UY	VG	VH	Key ⁴	M
32	S2	2.98	5.95	1.375	1.96	1.523	5.20	.55	5/16 X 5/16 X 1 13/16	1/2-13 X 1.00
33	S2	3.47	6.94	1.500	2.16	1.674	5.96	.55	3/8 X 3/8 X 2 1/4	5/8-11 X 1.75
34	S2	4.49	8.97	2.000	2.56	2.210	7.44	.79	1/2 X 7/16 X 2 5/8	5/8-11 X 1.75
35	S2	4.83	9.66	2.375	3.54	2.656	8.15	.94	5/8 X 5/8 X 3 5/8	3/4-10 X 2.00

Output Flange

Gear Frame	Flange Code	AK	AJ	BB	BD	BE	BF
32	5	5.118	6.50	.14	7.87	.39	.47
	6	7.087	8.46	.16	9.84	.47	.55
33	5	7.087	8.46	.16	9.84	.47	.55
	6	9.055	10.43	.16	11.81	.47	.55
34	5	9.055	10.43	.16	11.81	.59	.55
	6	9.842	11.80	.16	13.77	.59	.71
35	5	9.842	11.80	.20	13.77	.71	.71
	6	11.810	13.77	.20	15.75	.71	.71

C-Face Input

Motor Frame	Gear Frame	AJ1	AK1	BF1	U1	RU	BDX	Key1
56C	Any	5.88	4.50	.38	.625	3.54	6.50	3/16 Sq.
143TC/145TC	Any	5.88	4.50	.38	.875	3.54	6.50	3/16 Sq.
182TC/184TC	Any	7.25	8.50	.50	1.125	5.26	9.00	1/4 Sq.
213TC/215TC	33,34,35	7.25	8.50	.50	1.375	5.26	9.00	5/16 Sq.
254TC/256TC	35	7.25	8.50	.50	1.625	6.12	9.00	3/8 Sq.
284TC/286TC	35	9.00	10.50	.50	1.875	7.09	11.25	1/2 Sq.

¹ Dimension "D" will never be exceeded, but may vary from values shown. When exact dimensions are required, shims up to .03" may be necessary.

² All rough casting dimensions may vary by .25" due to casting variations.

³ Driven shaft entry can be from either side of the gear reducer housing by reversing positioning of the snap rings and washer illustrated.

⁴ Output key supplied only on frame 34 in "S2" version.

⁵ Output bore tolerances: +.0020", -.0000" for all diameters.

3-Stage Finished Bore Hollow Shaft Flange Mount OtN26 - 28

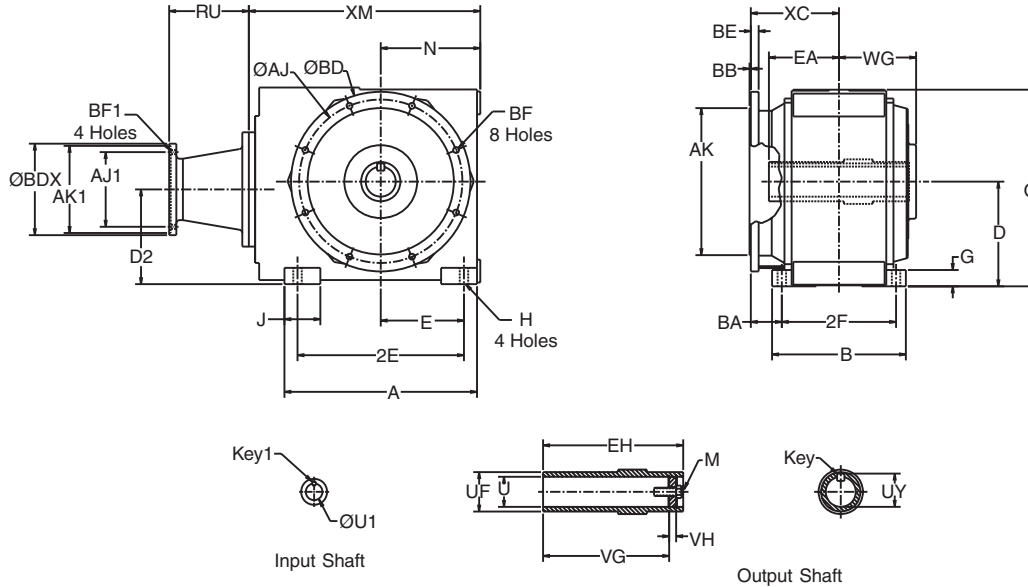

OtN Series

Gear Frame	Version	A	B	D ¹	D2	E	2E	2F	G	H	J	O	N	BA	XC	WG	XM
26	S1	16.73	11.42	8.86	8.43	6.99	13.98	9.45	1.57	.87	3.54	16.65	8.74	3.54	9.00	6.97	20.15
27	S1	19.29	12.60	9.84	8.66	8.27	16.54	10.63	1.77	.94	3.94	18.50	10.04	3.54	8.55	7.72	23.00
28	S1	23.23	16.14	12.40	11.42	10.04	20.08	13.78	1.97	1.02	4.33	23.70	12.01	3.74	11.51	9.49	30.05

Output Shaft

Gear Frame	Version	EA	EH	U ⁴	UF	UY	VG	VH	Key	M
26	S1	6.10	12.20	2.750	3.35	3.027	10.25	.91	5/8 Sq.	3/4-10
27	S1	6.70	13.40	3.125	3.75	3.454	11.40	.91	3/4 Sq.	3/4-10
28	S1	8.45	16.90	3.625	4.35	4.009	14.95	1.02	7/8 Sq.	1-8

Output Flange

Gear Frame	Flange Code	AJ	AK	BB	BD	BE	BF
26	5	15.75	13.75	.20	17.72	.79	.71
27	5	15.75	13.78	.20	17.72	.79	.71
28	5	19.69	17.72	.24	21.65	.94	.71

C-Face Input

Motor Frame	Gear Frame	AJ1	AK1	BF1	U1	RU	BDX	Key1
182TC/184TC	26	7.25	8.50	.50	1.125	6.97	9.06	1/4 Sq.
	27	7.25	8.50	.50	1.125	7.95	9.06	1/4 Sq.
213TC/215TC	26	7.25	8.50	.50	1.375	6.97	9.06	5/16 Sq.
	27	7.25	8.50	.50	1.375	7.95	9.06	5/16 Sq.
	28	7.25	8.50	.50	1.375	7.68	9.06	5/16 Sq.
254TC/256TC	26	7.25	8.50	.50	1.625	6.12	9.06	3/8 Sq.
	27	7.25	8.50	.50	1.625	7.95	9.06	3/8 Sq.
	28	7.25	8.50	.50	1.625	7.68	9.06	3/8 Sq.
284TC/286TC	26	9.00	10.50	.50	1.875	7.09	11.02	1/2 Sq.
	27	9.00	10.50	.50	1.875	8.66	11.02	1/2 Sq.
	28	9.00	10.50	.50	1.875	8.39	11.02	1/2 Sq.
324TC/326TC	28	11.00	12.50	.63	2.125	9.38	13.19	1/2 Sq.

¹ Dimension "D" will never be exceeded, but may vary from values shown. When exact dimensions are required, shims up to .03" may be necessary. ² All rough casting dimensions may vary by .25" due to casting variations. ³ Driven shaft entry can be from either side of the gear reducer housing by reversing positioning of the snap rings and washer illustrated. ⁴ Output bore tolerances: +.0020", -.0000" for all diameters.

Combined Finished Bore Hollow Shaft Flange Mount OtN32 - 35

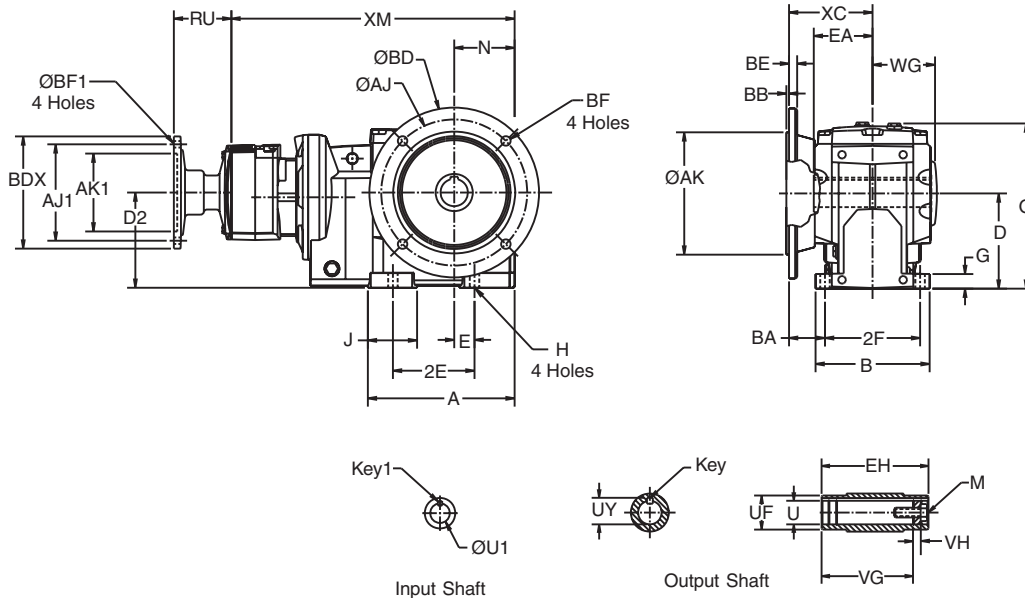

Gear Frame	Version	A	B	D ¹	D2	E	2E	2F	G	H	J	O	N	BA	WG	XC	XM
32	S2	7.81	5.71	4.41	4.06	1.38	5.12	4.71	.73	.43	2.34	8.09	3.03	1.81	3.22	4.04	14.49
33,33A	S2	8.50	6.61	5.51	4.91	1.18	4.72	5.51	.85	.55	2.86	9.69	3.54	2.08	3.73	4.84	19.90 ³
34	S2	10.13	7.87	7.09	5.57	1.57	5.91	6.50	1.07	.71	2.67	12.05	4.49	1.93	4.66	5.18	21.55
35	S2	11.92	8.66	8.35	6.56	2.17	7.09	7.09	1.18	.87	3.45	13.58	5.20	2.22	5.15	5.77	23.87

Output Shaft

Gear Frame	Version	EA	EH	U ⁶	UF	UY	VG	VH	Key ⁵	M
32	S2	2.98	5.95	1.375	1.96	1.523	5.20	.55	5/16 X 5/16 X 1 13/16	1/2-13 X 1.00
33,33A	S2	3.47	6.94	1.500	2.16	1.674	5.96	.55	3/8 X 3/8 X 2 1/4	5/8-11 X 1.75
34	S2	4.49	8.97	2.000	2.56	2.210	7.44	.79	1/2 X 7/16 X 2 5/8	5/8-11 X 1.75
35	S2	4.83	9.66	2.375	3.54	2.656	8.15	.94	5/8 X 5/8 X 3 5/8	3/4-10 X 2.00

Output Flange

Gear Frame	Flange Code	AK	AJ	BB	BD	BE	BF
32	5	5.118	6.50	.14	7.87	.39	.47
	6	7.087	8.46	.16	9.84	.47	.55
33,33A	5	7.087	8.46	.16	9.84	.47	.55
	6	9.055	10.43	.16	11.81	.47	.55
34	5	9.055	10.43	.16	11.81	.59	.55
	6	9.842	11.80	.16	13.77	.59	.71
35	5	9.842	11.80	.20	13.77	.71	.71
	6	11.810	13.77	.20	15.75	.71	.71

C-Face Input

Motor Frame	Gear Frame	AJ1	AK1	BF1	U1	RU	BDX	Key1
56C	32,33A	5.88	4.50	.38	.625	3.33	6.50	3/16 Sq.
	33,34,35	5.88	4.50	.38	.625	3.54	6.50	3/16 Sq.
143TC/145TC	32,33A	5.88	4.50	.38	.875	3.33	6.50	3/16 Sq.
	33,34,35	5.88	4.50	.38	.875	3.54	6.50	3/16 Sq.
182TC/184TC	33,34,35	7.25	8.50	.50	1.125	5.26	9.00	1/4 Sq.

¹ Dimension "D" will never be exceeded, but may vary from values shown. When exact dimensions are required, shims up to .03" may be necessary.
² All rough casting dimensions may vary by .25" due to casting variations.
³ XM dimension when gear frame 33A is used will be 16.42.
⁴ Driven shaft entry can be from either side of the gear reducer housing by reversing positioning of the snap rings and washer illustrated.
⁵ Output key supplied only on frame 34 in "S2" version.
⁶ Output bore tolerances: +.0020", -.0000" for all diameters.

Combined Finished Bore Hollow Shaft Flange Mount OtN26 - 28

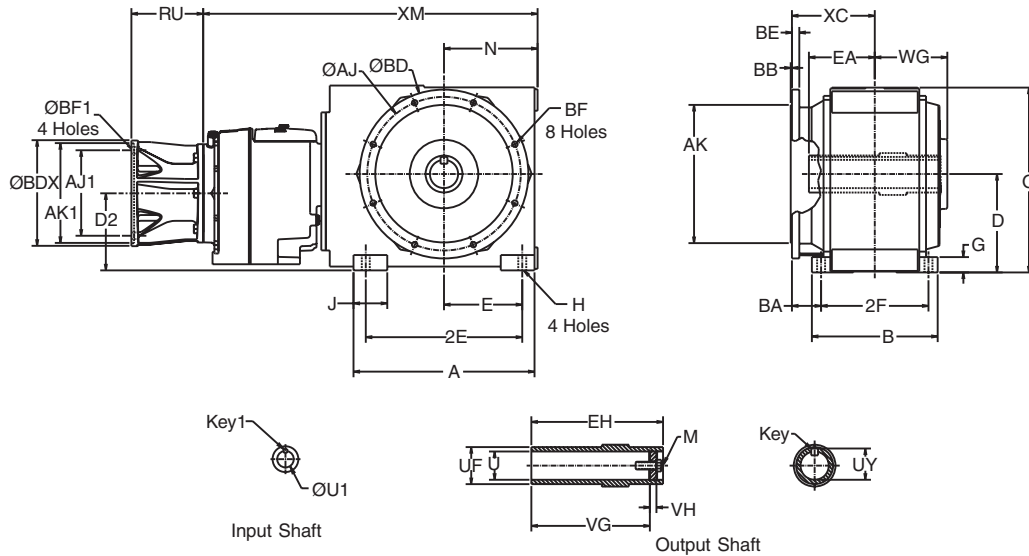

OtN Series

Gear Frame	Version	A	B	D ¹	D2	E	2E	2F	G	H	J	O	N	BA	WG	XC	XM	
																	56C-215TC	254TC-Up
26A	S1	16.73	11.42	8.86	7.66	6.99	13.98	9.45	1.57	.87	3.54	16.65	8.74	3.54	6.97	9.00	30.80	-
27A	S1	19.29	12.60	9.84	7.89	8.27	16.54	10.63	1.77	.94	3.94	18.50	10.04	3.54	7.72	8.55	31.47	-
28A	S1	23.23	16.14	12.40	10.40	10.04	20.08	13.78	1.97	1.02	4.33	23.70	12.01	3.74	9.49	11.57	37.14	37.49

Output Shaft

Gear Frame	Version	EA	EH	U ⁴	UF	UY	VG	VH	Key	M
26A	S1	6.10	12.20	2.750	3.35	3.027	10.25	.91	5/8 Sq.	3/4-10
27A	S1	6.70	13.40	3.125	3.75	3.454	11.40	.91	3/4 Sq.	3/4-10
28A	S1	8.45	16.90	3.625	4.35	4.009	14.95	1.02	7/8 Sq.	1-8

Output Flange

Gear Frame	Flange Code	AJ	AK	BB	BD	BE	BF
26A	5	15.75	13.75	.20	17.72	.79	.71
27A	5	15.75	13.78	.20	17.72	.79	.71
28A	5	19.69	17.72	.24	21.65	.94	.71

C-Face Input

Motor Frame	Gear Frame	AJ1	AK1	BF1	U1	RU	BDX	Key1
56C	Any	5.88	4.50	.38	.625	3.54	6.50	3/16 Sq.
143TC/145TC	Any	5.88	4.50	.38	.875	3.54	6.50	3/16 Sq.
182TC/184TC	Any	7.25	8.50	.50	1.125	5.26	9.06	1/4 Sq.
213TC/215TC	Any	7.25	8.50	.50	1.375	5.26	9.06	5/16 Sq.
254TC/256TC	28A	7.25	8.50	.50	1.625	6.12	9.06	3/8 Sq.
284TC/286TC	28A	9.00	10.50	.50	1.875	7.09	11.02	1/2 Sq.

¹ Dimension "D" will never be exceeded, but may vary from values shown. When exact dimensions are required, shims up to .03" may be necessary.
² All rough casting dimensions may vary by .25" due to casting variations.
³ Driven shaft entry can be from either side of the gear reducer housing by reversing positioning of the snap rings and washer illustrated.
⁴ Output bore tolerances: +.0020", -.0000" for all diameters.

3-Stage Taper Bushed Shaft Mount OtN32 - 35

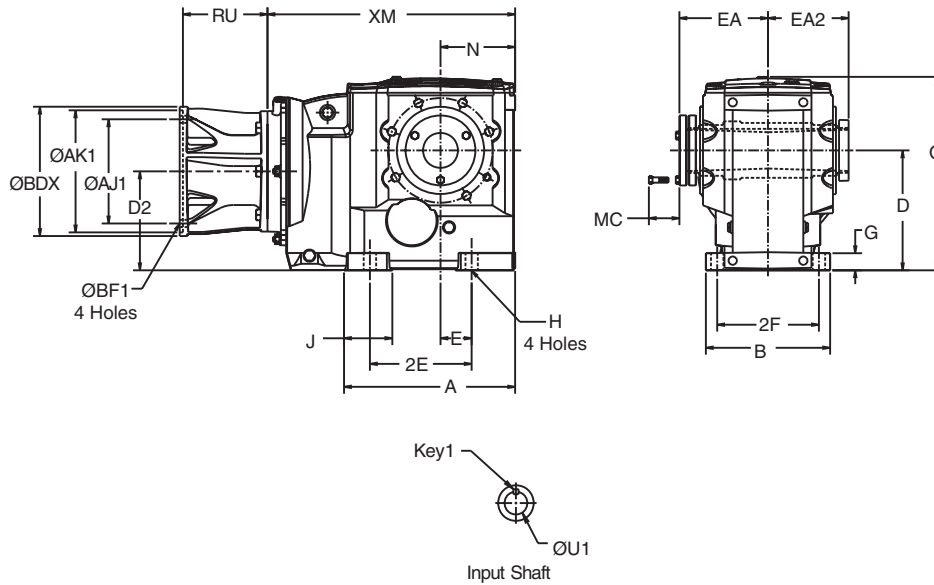

Gear Frame	Version	A	B	D ¹	D2	E	2E	2F	G	H	J	O	N	XM	
														56C-215TC	254TC-286TC
32	S2	7.81	5.71	4.41	3.78	1.38	5.12	4.71	.73	.43	2.34	8.09	3.03	10.98	-
33	S2	8.50	6.61	5.51	5.24	1.18	4.72	5.51	.85	.55	2.86	9.69	3.54	12.90	-
34	S2	10.13	7.87	7.09	5.90	1.57	5.91	6.50	1.07	.71	2.67	12.05	4.49	14.56	-
35	S2	11.92	8.66	8.35	6.89	2.17	7.09	7.09	1.18	.87	3.45	13.58	5.20	16.90	17.25

Output Shaft

Gear Frame	Version	EA	EA2	MC ⁴	Bushing Bores ³	
					Min.	Max.
32	S2	4.85	4.27	1.75	3/4	1 7/16
33	S2	4.82	4.23	1.75	3/4	1 7/16
34	S2	5.84	5.27	1.88	15/16	1 15/16
35	S2	6.17	5.620	1.88	1 3/8	2 7/16

C-Face Input

Motor Frame	Gear Frame	AJ1	AK1	BF1	U1	RU	BDX	Key1
56C	Any	5.88	4.50	.38	.625	3.54	6.50	3/16 Sq.
143TC/145TC	Any	5.88	4.50	.38	.875	3.54	6.50	3/16 Sq.
182TC/184TC	Any	7.25	8.50	.50	1.125	5.26	9.00	1/4 Sq.
213TC/215TC	33,34,35	7.25	8.50	.50	1.375	5.26	9.00	5/16 Sq.
254TC/256TC	35	7.25	8.50	.50	1.625	6.12	9.00	3/8 Sq.
284TC/286TC	35	9.00	10.50	.50	1.875	7.09	11.25	1/2 Sq.

¹ Dimension "D" will never be exceeded, but may vary from values shown. When exact dimensions are required, shims up to .03" may be necessary.

² All rough casting dimensions may vary by .25" due to casting variations.

³ Refer to page B-116 by gear frame for listing of all inch and metric bushing bore sizes available.

⁴ The MC dimension shows spacing required to install or remove the bushing from the reducer.

⁵ Bushing and dust cap can be installed opposite of how they are shown above.

⁶ Driven shaft entry can be from either side of the gear reducer housing. Refer to installation manual for requirements.

⁷ For details of the torque arm kit, refer to page B-114.

Combined Taper Bushed Shaft Mount OtN32 - 35

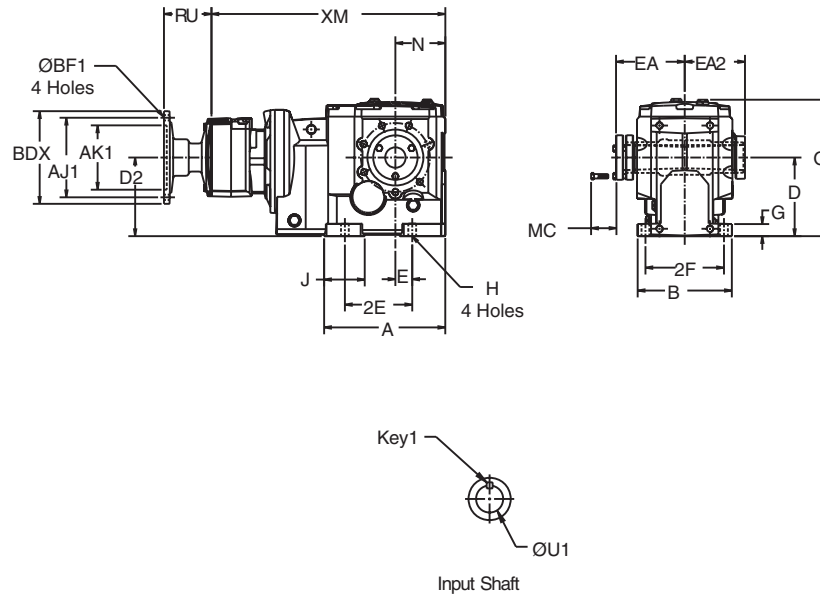

OtN Series

Gear Frame	Version	A	B	D'	D2	E	2E	2F	G	H	J	O	N	XM
32	S2	7.81	5.71	4.41	4.06	1.38	5.12	4.72	.73	.43	2.34	8.09	3.03	14.49
33,33A	S2	8.50	6.61	5.51	4.91	1.18	4.72	5.51	.85	.55	2.86	9.69	3.54	19.90 ⁸
34	S2	10.13	7.87	7.09	5.57	1.57	5.91	6.50	1.07	.71	2.67	12.05	4.49	21.55
35	S2	11.92	8.66	8.35	6.56	2.17	7.09	7.09	1.18	.87	3.45	13.58	5.20	23.87

Output Shaft

Gear Frame	Version	EA	EA2	MC ⁴	Bushing Bores ³	
					Min.	Max.
32	S2	4.85	4.27	1.75	3/4	1 7/16
33,33A	S2	4.82	4.23	1.75	3/4	1 7/16
34	S2	5.84	5.27	1.88	15/16	1 15/16
35	S2	6.17	5.620	1.88	1 3/8	2 7/16

C-Face Input

Motor Frame	Gear Frame	AJ1	AK1	BF1	U1	RU	BDX	Key1
56C	32,33A	5.88	4.50	.38	.625	3.33	6.50	3/16 Sq.
	33,34,35	5.88	4.50	.38	.625	3.54	6.50	3/16 Sq.
143TC/145TC	32,33A	5.88	4.50	.38	.875	3.33	6.50	3/16 Sq.
	33,34,35	5.88	4.50	.38	.875	3.54	6.50	3/16 Sq.
182TC/184TC	33,34,35	7.25	8.50	.50	1.125	5.26	9.00	1/4 Sq.

¹ Dimension "D" will never be exceeded, but may vary from values shown. When exact dimensions are required, shims up to .03" may be necessary.

² All rough casting dimensions may vary by .25" due to casting variations.

³ Refer to page B-116 by gear frame for listing of all inch and metric bushing bore sizes available.

⁴ The MC dimension shows spacing required to install or remove the bushing from the reducer.

⁵ Bushing and dust cap can be installed opposite of how they are shown above.

⁶ Driven shaft entry can be from either side of the gear reducer housing. Refer to installation manual for requirements.

⁷ For details of the torque arm kit, refer to page B-114.

⁸ XM dimension when gear frame 33A is used will be 16.42.

3-Stage Output Shafted Foot Mount OtN32 - 35 and OtN26 - 28

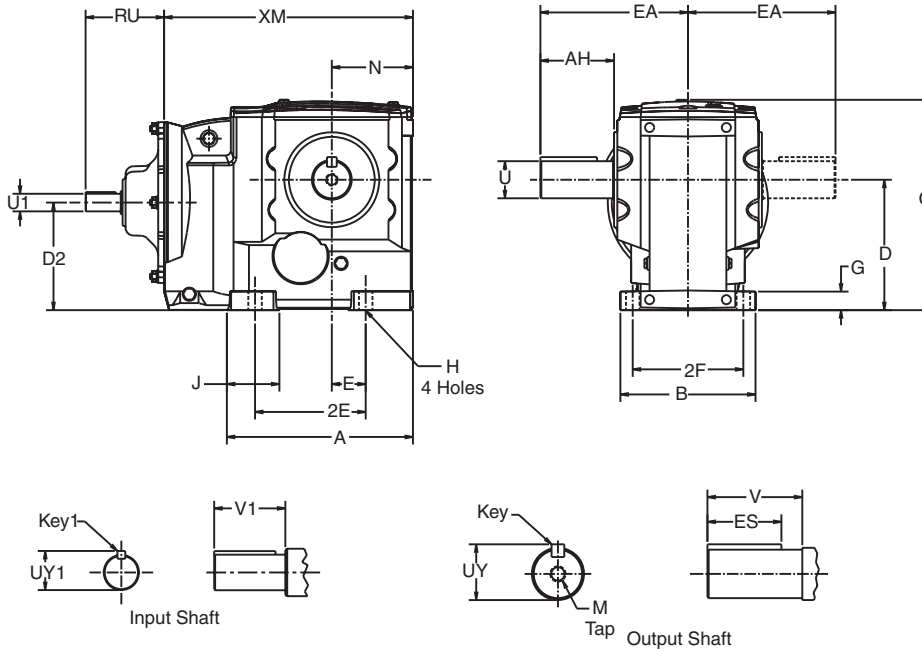

Gear Frame	Version	A	B	D ¹	D2	E	2E	2F	G	H	J	O	N	XM
32	S2	7.81	5.71	4.41	3.78	1.38	5.12	4.72	.73	.43	2.34	8.09	3.03	10.04
	S1	8.50	6.61	5.51	5.24	1.18	4.72	5.51	.85	.55	2.86	9.69	3.54	11.97
33	S2	8.08	8.58	4.92	5.20	3.35	6.69	6.10	.79	.55	2.27	10.43	3.54	11.97
	S1	10.13	7.87	7.09	5.90	1.57	5.91	6.50	1.07	.71	2.67	12.05	4.49	13.78
34	S2	10.69	9.60	6.30	7.49	4.53	9.06	7.68	1.18	.71	3.19	13.39	4.49	13.78
	S1	11.92	8.66	8.35	6.89	2.17	7.09	7.09	1.18	.87	3.37	13.58	5.20	15.95
35	S2	13.07	10.98	7.87	9.33	5.51	11.02	9.06	1.40	.87	4.05	16.22	5.20	15.95
	S1	16.73	11.42	8.86	8.43	6.99	13.98	9.45	1.57	.87	3.54	16.65	8.74	20.15
26	S1	19.29	12.60	9.84	8.66	8.27	16.54	10.63	1.77	.94	3.94	18.50	10.04	22.24
27	S1	23.23	16.14	12.40	11.42	10.04	20.08	13.78	1.97	1.02	4.33	23.70	12.01	27.16

Output Shaft

Gear Frame	Version	U ³	UY	V	AH	EA	Key	ES	M
32	S2	1.250	1.354	2.36	2.46	5.31	1/4 Sq.	2.06	1/2-13 X 1.12
	S1	1.625	1.783	3.25	3.39	6.73	3/8 Sq.	2.78	5/8-11 X 1.38
33	S2	1.500	1.657	3.18	3.19	7.12	3/8 Sq.	2.78	5/8-11 X 1.38
	S1	2.000	2.210	3.63	3.76	8.11	1/2 Sq.	3.06	3/4-10 X 1.61
34	S2	1.750	1.909	3.56	3.66	8.46	3/8 Sq.	3.56	3/4-10 X 1.61
	S1	2.375	2.638	4.61	4.74	9.45	5/8 Sq.	3.81	3/4-10 X 1.61
35	S2	2.375	2.638	5.73	5.27	10.57	5/8 Sq.	4.81	3/4-10 X 1.61
	S1	2.875	3.200	5.75	5.91	12.82	3/4 Sq.	5.13	3/4-10 X 1.97
26	S1	3.500	3.882	7.01	7.33	13.70	7/8 Sq.	6.25	1-8 X 1.97
27	S1	3.875	4.426	7.99	8.19	17.06	1.00 Sq.	7.25	1-8 X 1.97

Input Shaft

Gear Frame	Version	RU	U1 ⁴	UY1	V1	Key1
32	S2	3.17	.625	.705	1.25	3/16 Sq.
33	S1,S2	3.17	.625	.705	1.25	3/16 Sq.
	S1,S2	4.75	1.125	1.236	2.25	1/4 Sq.
35	S1,S2	5.03	1.125	1.236	2.25	1/4 Sq.
26	S1	6.49	1.375	1.513	2.75	5/16 Sq.
27	S1	5.76	1.875	2.091	3.75	1/2 Sq.
28	S1	7.11	2.375	2.646	4.75	5/8 Sq.

¹ Dimension "D" will never be exceeded, but may vary from values shown. When exact dimensions are required, shims up to .03" may be necessary.

² All rough casting dimensions may vary by .25" due to casting variations.

³ Output shaft extension tolerances: +.0000"; -.0005" for shafts up to 1.5" diameter "U". Larger diameter "U", +.000"; -.001".

⁴ Input shaft extension tolerances: +.0000"; -.0005" up to 1.5" diameter. Larger diameter "U1", +.000"; -.001".

Combined Output Shafted Foot Mount OtN32 - 35 and OtN26 - 28

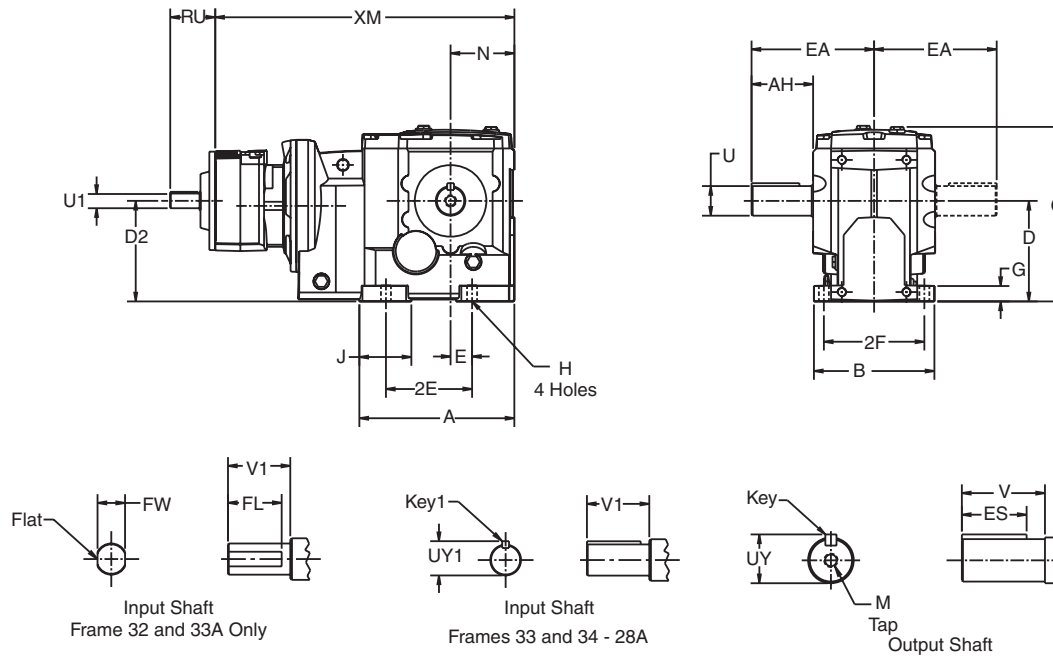

OtN Series

Gear Frame	Version	A	B	D ¹	D2	E	2E	2F	G	H	J	O	N	XM
32	S2	7.81	5.71	4.41	4.06	1.38	5.12	4.72	.73	.43	2.34	8.09	3.03	14.49
33,33A	S2	8.50	6.61	5.51	4.91	1.18	4.72	5.51	.85	.55	2.86	9.69	3.54	19.90 ⁴
	S1	8.08	8.58	4.92	4.87	3.35	6.69	6.10	.79	.55	2.27	10.43	3.54	19.90 ⁴
34	S2	10.13	7.87	7.09	5.57	1.57	5.91	6.50	1.07	.71	2.67	12.05	4.49	21.55
	S1	10.69	9.60	6.30	7.16	4.53	9.06	7.68	1.18	.71	3.19	13.39	4.49	21.55
35	S2	11.92	8.66	8.35	6.56	2.17	7.09	7.09	1.18	.87	3.37	13.58	5.20	23.87
	S1	13.07	10.98	7.87	9.00	5.51	11.02	9.06	1.40	.87	4.05	16.22	5.20	23.87
26A	S1	16.73	11.42	8.86	7.66	6.99	13.98	9.45	1.57	.87	3.54	16.65	8.74	30.80
27A	S1	19.29	12.60	9.84	7.89	8.27	16.54	10.63	1.77	.94	3.94	18.50	10.04	31.47
28A	S1	23.23	16.14	12.40	10.40	10.04	20.08	13.78	1.97	1.02	4.33	23.70	12.01	37.49

Output Shaft

Gear Frame	Version	U ³	UY	V	AH	EA	Key	ES	M
32	S2	1.250	1.354	2.36	2.46	5.31	1/4 Sq.	2.06	1/2-13 X 1.12
33,33A	S2	1.625	1.783	3.25	3.39	6.73	3/8 Sq.	2.78	5/8-11 X 1.38
	S1	1.500	1.657	3.18	3.19	7.12	3/8 Sq.	2.78	5/8-11 X 1.38
34	S2	2.000	2.210	3.63	3.76	8.11	1/2 Sq.	3.06	3/4-10 X 1.61
	S1	1.750	1.909	3.56	3.66	8.46	3/8 Sq.	3.56	3/4-10 X 1.61
35	S2	2.375	2.638	4.61	4.74	9.45	5/8 Sq.	3.81	3/4-10 X 1.61
	S1	2.375	2.638	5.73	5.27	10.57	5/8 Sq.	4.81	3/4-10 X 1.61
26A	S1	2.875	3.200	5.75	5.91	12.82	3/4 Sq.	5.13	3/4-10 X 1.97
27A	S1	3.500	3.882	7.01	7.33	13.70	7/8 Sq.	6.25	1-8 X 1.97
28A	S1	3.875	4.426	7.99	8.19	17.06	1.00 Sq.	7.25	1-8 X 1.97

Input Shaft

Gear Frame	Version	RU	U1 ⁵	FL	FW	UY1	V1	Key1
32,33A	S2	3.60	.500	.86	.46	-	1.00	-
33	S1,S2	3.17	.625	-	-	.705	1.25	3/16 Sq.
34	S1,S2	3.17	.625	-	-	.705	1.25	3/16 Sq.
35	S1,S2	3.17	.625	-	-	.705	1.25	3/16 Sq.
26A	S1	4.75	1.125	-	-	1.236	2.25	1/4 Sq.
27A	S1	4.75	1.125	-	-	1.236	2.25	1/4 Sq.
28A	S1	5.03	1.125	-	-	1.236	2.25	1/4 Sq.

¹ Dimension "D" will never be exceeded, but may vary from values shown. When exact dimensions are required, shims up to .03" may be necessary.
² All rough casting dimensions may vary by .25" due to casting variations.
³ Output shaft extension tolerances: +.0000"; -.0005" for shafts up to 1.5" diameter "U". Larger diameter "U", +.000"; -.001".
⁴ XM dimension when gear frame 33A is used will be 16.42.
⁵ Input shaft extension tolerances: +.0000"; -.0005" up to 1.5" diameter. Larger diameter "U1", +.000"; -.001".

3-Stage Output Shafted Flange Mount OtN32 - 35

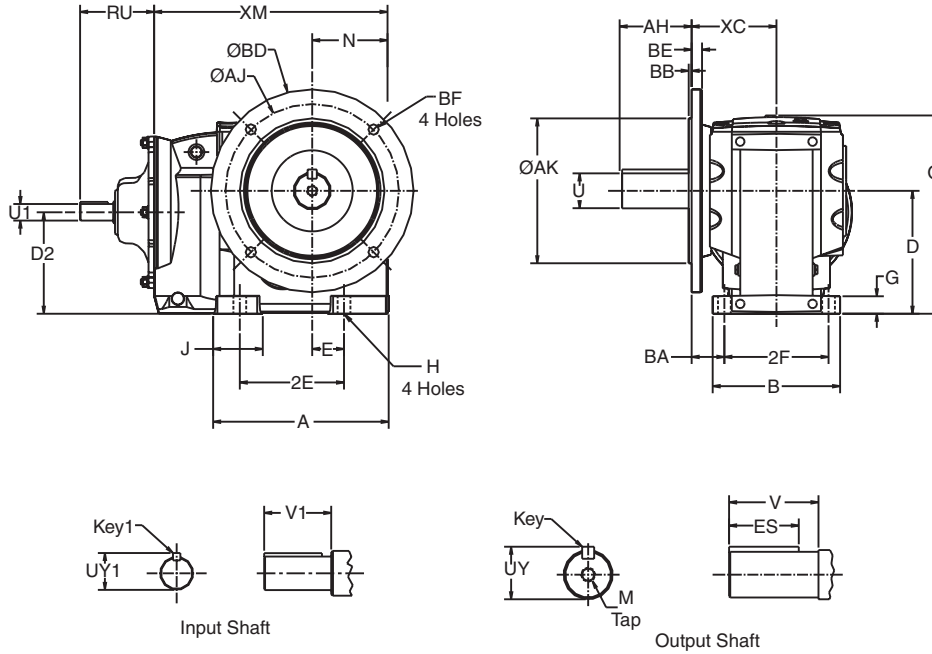

Gear Frame	Version	A	B	D ¹	D2	E	2E	2F	G	H	J	O	N	BA	XC	XM
32	S1, S2	7.81	5.71	4.41	3.78	1.38	5.12	4.71	.73	.43	2.34	8.09	3.03	1.81	4.04	10.04
33	S1, S2	8.50	6.61	5.51	5.24	1.18	4.72	5.51	.85	.55	2.86	9.69	3.54	2.24	4.84	11.97
34	S1, S2	10.13	7.87	7.09	5.90	1.57	5.91	6.50	1.07	.71	2.67	12.05	4.49	1.93	5.18	13.78
35	S2	11.92	8.66	8.35	6.89	2.17	7.09	7.09	1.18	.87	3.45	13.58	5.20	2.22	5.76	15.95

Output Shaft

Gear Frame	Version	U ³	UY	V	AH	Key	ES	M
32	S2	1.250	1.354	2.38	2.36	1/4 Sq.	2.06	1/2-13 X 1.12
	S1	1.250	1.354	1.77	1.75	1/4 Sq.	1.45	1/2-13 X 1.12
33	S2	1.625	1.783	3.25	3.38	3/8 Sq.	2.78	5/8-11 X 1.38
	S1	1.500	1.657	3.18	2.28	3/8 Sq.	2.19	5/8-11 X 1.38
34	S2	2.000	2.210	3.94	3.94	1/2 Sq.	3.06	3/4-11 X 1.61
	S1	1.750	1.909	3.56	3.28	3/8 Sq.	3.56	3/4-11 X 1.61
35	S2	2.375	2.646	4.72	4.72	5/8 Sq.	3.81	3/4-11 X 1.61

Output Flange

Gear Frame	Flange Code	AK	AJ	BB	BD	BE	BF
32	5	5.118	6.50	.14	7.87	.39	.47
	6	7.087	8.46	.16	9.84	.47	.55
33	5	7.087	8.46	.16	9.84	.47	.55
	6	9.055	10.43	.16	11.81	.47	.55
34	5	9.055	10.43	.16	11.81	.59	.55
	6	9.842	11.80	.16	13.77	.59	.71
35	5	9.842	11.80	.20	13.77	.71	.71
	6	11.810	13.77	.20	15.75	.71	.71

Input Shaft

Gear Frame	Version	RU	U1 ⁴	UY1	V1	Key1
32	S1,S2	3.17	.625	.705	1.25	3/16 Sq.
33	S1,S2	3.17	.625	.705	1.25	3/16 Sq.
34	S1,S2	4.75	1.125	1.236	2.25	1/4 Sq.
35	S2	5.03	1.125	1.236	2.25	1/4 Sq.

¹ Dimension "D" will never be exceeded, but may vary from values shown. When exact dimensions are required, shims up to .03" may be necessary.

² All rough casting dimensions may vary by .25" due to casting variations.

³ Output shaft extension tolerances: +.0000"; -.0005" for shafts up to 1.5" diameter "U". Larger diameter "U", +.000"; -.001".

⁴ Input shaft extension tolerances: +.0000"; -.0005" up to 1.5" diameter. Larger diameter "U1", +.000"; -.001".

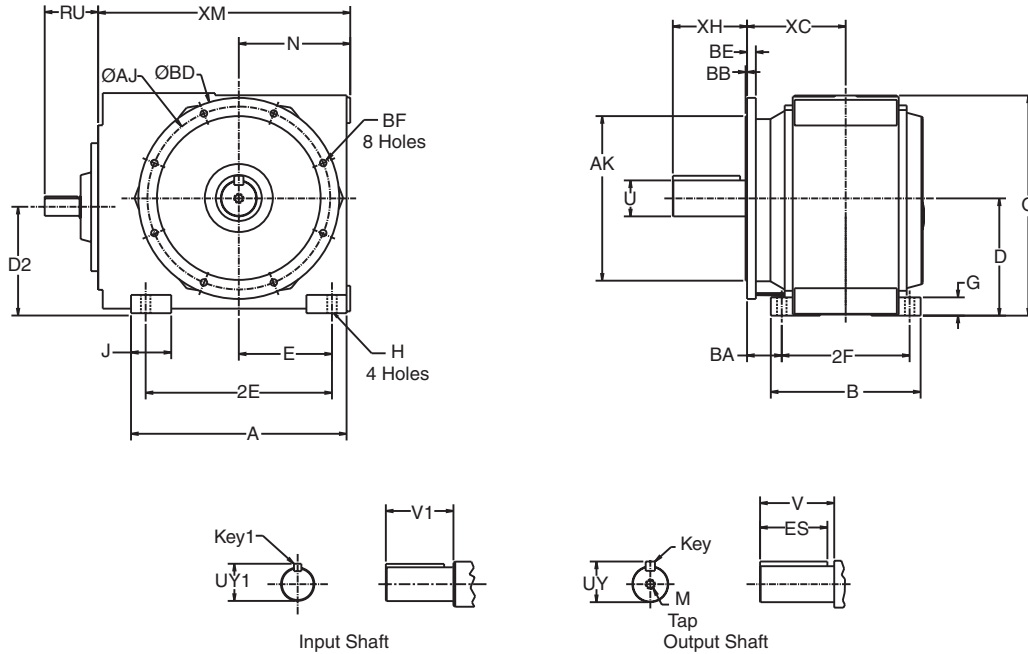

Gear Frame	Version	A	B	D ¹	D2	E	2E	2F	G	H	J	O	N	BA	XC	XM
26	S1	16.73	11.42	8.86	8.43	6.99	13.98	9.45	1.57	.87	3.54	16.65	8.74	3.54	9.00	20.15
27	S1	19.29	12.60	9.84	8.66	8.27	16.54	10.63	1.77	.94	3.94	18.50	10.04	3.54	8.55	22.24
28	S1	23.23	16.14	12.40	11.42	10.04	20.08	13.78	1.97	1.02	4.33	23.70	12.01	3.74	11.51	27.16

Output Shaft

Gear Frame	Version	U ³	UY	V	AH	Key	ES	M
26	S1	2.875	3.200	5.75	5.75	3/4 Sq.	5.13	3/4-10 X 1.97
27	S1	3.500	3.882	7.00	7.00	7/8 Sq.	6.25	1-8 X 1.97
28	S1	4.000	4.436	8.00	8.00	1.00 Sq.	7.25	1-8 X 1.97

Output Flange

Gear Frame	Flange Code	AJ	AK	BB	BD	BE	BF
26	5	15.75	13.75	.20	17.72	.79	.71
27	5	15.75	13.78	.20	17.72	.79	.71
28	5	19.69	17.72	.24	21.65	.94	.71

Input Shaft

Gear Frame	Version	RU	U1 ⁴	UY1	V1	Key1
26	S1	6.49	1.375	1.513	2.75	5/16 Sq.
27	S1	5.76	1.875	2.091	3.75	1/2 Sq.
28	S1	7.11	2.375	2.646	4.75	5/8 Sq.

¹ Dimension "D" will never be exceeded, but may vary from values shown. When exact dimensions are required, shims up to .03" may be necessary.

² All rough casting dimensions may vary by .25" due to casting variations.

³ Output shaft extension tolerances: +.0000"; -.0005" for shafts up to 1.5" diameter "U". Larger diameter "U", +.000"; -.001".

⁴ Input shaft extension tolerances: +.0000"; -.0005" up to 1.5" diameter. Larger diameter "U1", +.000"; -.001".

Combined Output Shafted Flange Mount OtN32 - 35

OtN Series

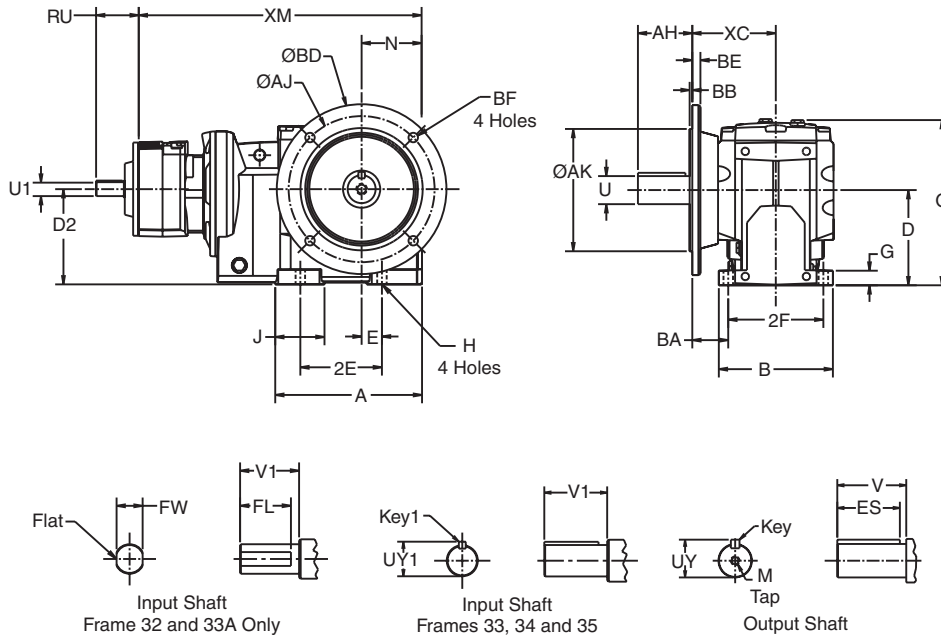

Gear Frame	Version	A	B	D ¹	D2	E	2E	2F	G	H	J	O	N	BA	XC	XM
32	S1,S2	7.81	5.71	4.41	4.06	1.38	5.12	4.71	.73	.43	2.34	8.09	3.03	1.81	4.04	14.49
33,33A	S1,S2	8.50	6.61	5.51	4.91	1.18	4.72	5.51	.85	.55	2.86	9.69	3.54	2.24	4.84	19.90 ⁴
34	S1,S2	10.13	7.87	7.09	5.57	1.57	5.91	6.50	1.07	.71	2.67	12.05	4.49	1.93	5.18	21.55
35	S2	11.92	8.66	8.35	6.56	2.17	7.09	7.09	1.18	.87	3.45	13.58	5.20	2.22	5.76	23.87

Output Shaft

Gear Frame	Version	U ³	UY	V	AH	Key	ES	M
32	S2	1.250	1.354	2.38	2.36	1/4 Sq.	2.06	1/2-13 X 1.12
	S1	1.250	1.354	1.77	1.75	1/4 Sq.	1.45	1/2-13 X 1.12
33,33A	S2	1.625	1.783	3.25	3.38	3/8 Sq.	2.78	5/8-11 X 1.38
	S1	1.500	1.657	3.18	2.28	3/8 Sq.	2.19	5/8-11 X 1.38
34	S2	2.000	2.210	3.94	3.94	1/2 Sq.	3.06	3/4-10 X 1.61
	S1	1.750	1.909	3.56	3.28	3/8 Sq.	3.56	3/4-10 X 1.61
35	S2	2.375	2.638	4.72	4.72	5/8 Sq.	3.81	3/4-10 X 1.61

Output Flange

Gear Frame	Flange Code	AK	AJ	BB	BD	BE	BF
32	5	5.118	6.50	.14	7.87	.39	.47
	6	7.087	8.46	.16	9.84	.47	.55
33,33A	5	7.087	8.46	.16	9.84	.47	.55
	6	9.055	10.43	.16	11.81	.47	.55
34	5	9.055	10.43	.16	11.81	.59	.55
	6	9.842	11.80	.16	13.77	.59	.71
35	5	9.842	11.80	.20	13.77	.71	.71
	6	11.810	13.77	.20	15.75	.71	.71

Input Shaft

Gear Frame	Version	RU	U1 ⁵	FL	FW	UY1	V1	Key1
32,33A	S1,S2	3.60	.500	.86	.46	-	1.00	-
33	S1,S2	3.17	.625	-	-	.705	1.25	3/16 Sq.
34	S1,S2	3.17	.625	-	-	.705	1.25	3/16 Sq.
35	S2	3.17	.625	-	-	.705	1.25	3/16 Sq.

¹ Dimension "D" will never be exceeded, but may vary from values shown.
² All rough casting dimensions may vary by .25" due to casting variations.
³ Output shaft extension tolerances: +.0000"; -.0005" for shafts up to 1.5" diameter "U". Larger diameter "U", +.000"; -.001".
⁴ XM dimension when gear frame 33A is used will be 16.42.
⁵ Input shaft extension tolerances: +.0000"; -.0005" up to 1.5" diameter. Larger diameter "U1", +.000"; -.001".

Combined Output Shafted Flange Mount OtN26 - 28

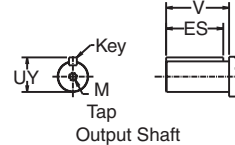
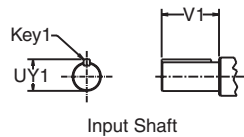
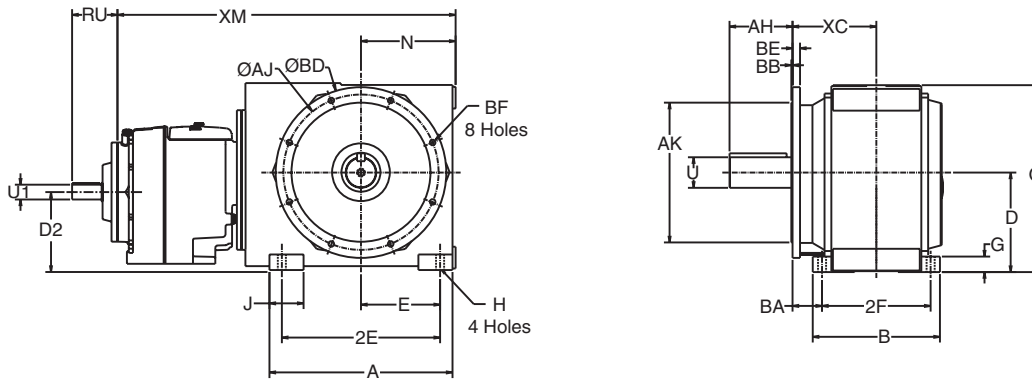

Gear Frame	Version	A	B	D ¹	D2	E	2E	2F	G	H	J	O	N	BA	XC	XM
26A	S1	16.73	11.42	8.86	7.66	6.99	13.98	9.45	1.57	.87	3.54	16.65	8.74	3.54	9.00	30.80
27A	S1	19.29	12.60	9.84	7.89	8.27	16.54	10.63	1.77	.94	3.94	18.50	10.04	3.54	8.55	31.47
28A	S1	23.23	16.14	12.40	10.40	10.04	20.08	13.78	1.97	1.02	4.33	23.70	12.01	3.74	11.51	37.49

Output Shaft

Gear Frame	Version	U ³	UY	V	AH	Key	ES	M
26A	S1	2.875	3.200	5.75	5.75	3/4 Sq.	5.13	3/4-10 X 1.97
27A	S1	3.500	3.882	7.00	7.00	7/8 Sq.	6.25	1-8 X 1.97
28A	S1	4.000	4.436	8.00	8.00	1.00 Sq.	7.25	1-8 X 1.97

Output Flange

Gear Frame	Flange Code	AJ	AK	BB	BD	BE	BF
26A	5	15.75	13.75	.20	17.72	.79	.71
27A	5	15.75	13.78	.20	17.72	.79	.71
28A	5	19.69	17.72	.24	21.65	.94	.71

Input Shaft

Gear Frame	Version	RU	U1 ⁴	UY1	V1	Key1
26A	S1	4.75	1.125	1.236	2.25	1/4 Sq.
27A	S1	4.75	1.125	1.236	2.25	1/4 Sq.
28A	S1	5.03	1.125	1.236	2.25	1/4 Sq.

¹ Dimension "D" will never be exceeded, but may vary from values shown. When exact dimensions are required, shims up to .03" may be necessary.

² All rough casting dimensions may vary by .25" due to casting variations.

³ Output shaft extension tolerances: +.0000"; -.0005" for shafts up to 1.5" diameter "U". Larger diameter "U", +.000"; -.001".

⁴ Input shaft extension tolerances: +.0000"; -.0005" up to 1.5" diameter. Larger diameter "U1", +.000"; -.001".

3-Stage Finished Bore Hollow Shaft Mount OtN32 - 35 and OtN26 - 28

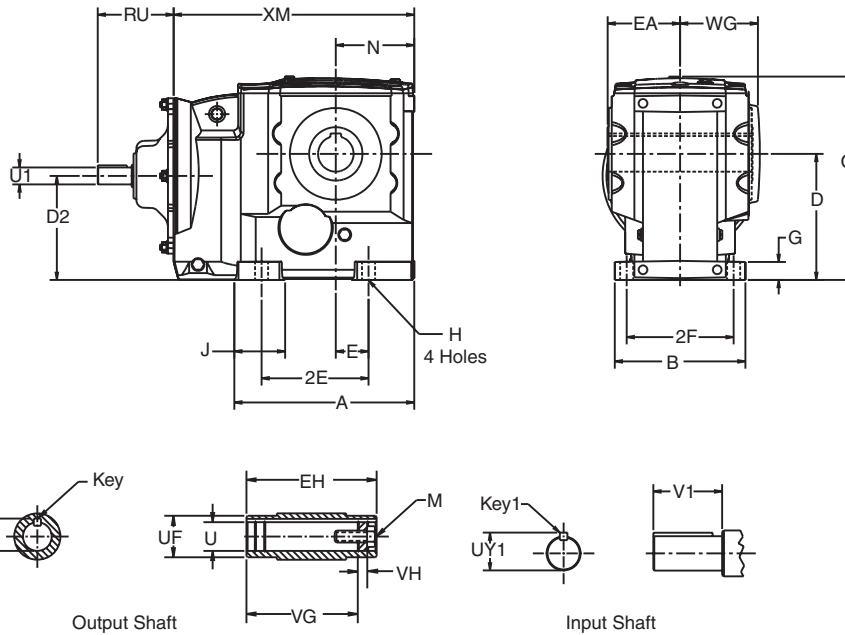

Gear Frame	Version	A	B	D ¹	D2	E	2E	2F	G	H	J	O	N	WG	XM
32	S2	7.81	5.71	4.41	3.78	1.38	5.12	4.71	.73	.43	2.34	8.09	3.03	3.22	10.04
33	S2	8.50	6.61	5.51	5.24	1.18	4.72	5.51	.85	.55	2.86	9.69	3.54	3.73	11.97
34	S2	10.13	7.87	7.09	5.90	1.57	5.91	6.50	1.07	.71	2.67	12.05	4.49	4.66	13.78
35	S2	11.92	8.66	8.35	6.89	2.17	7.09	7.09	1.18	.87	3.45	13.58	5.20	5.15	15.95
26	S1	16.73	11.42	8.86	8.43	6.99	13.98	9.45	1.57	.87	3.54	16.65	8.74	6.97	20.15
27	S1	19.29	12.60	9.84	8.66	8.27	16.54	10.63	1.77	.94	3.94	18.50	10.04	7.72	22.24
28	S1	23.23	16.14	12.40	11.42	10.04	20.08	13.78	1.97	1.02	4.33	23.70	12.01	9.49	27.16

Output Shaft

Gear Frame	Version	EA	EH	U ^{4,7}	UF	UY	VG	VH	Key ⁵	M
33	S2	3.47	6.94	1.500	2.16	1.674	5.96	.55	3/8 X 3/8 X 2 1/4	5/8-11 X 1.75
34	S2	4.49	8.97	2.000	2.56	2.210	7.44	.79	1/2 X 7/16 X 2 5/8	5/8-11 X 1.75
35	S2	4.83	9.66	2.375	3.54	2.656	8.15	.94	5/8 X 5/8 X 3 5/8	3/4-10 X 2.00

Input Shaft

Gear Frame	Version	RU	U1 ⁶	UY1	V1	Key1
32	S2	3.17	.625	.705	1.25	3/16 Sq.
33	S2	3.17	.625	.705	1.25	3/16 Sq.
34	S2	4.75	1.125	1.236	2.25	1/4 Sq.
35	S2	5.03	1.125	1.236	2.25	1/4 Sq.
26	S1	6.49	1.375	1.513	2.75	5/16 Sq.
27	S1	5.76	1.875	2.091	3.75	1/2 Sq.
28	S1	7.11	2.375	2.646	4.75	5/8 Sq.

¹ Dimension "D" will never be exceeded, but may vary from values shown. When exact dimensions are required, shims up to .03" may be necessary.
² All rough casting dimensions may vary by .25" due to casting variations.
³ Driven shaft entry can be from either side of the gear reducer housing by reversing positioning of the snap rings and washer illustrated.
⁴ Output finished bore tolerance: +.0020", -.0000 for all diameters.
⁵ Output key supplied only on frame 34 in "S2" version.
⁶ Input shaft extension tolerances: +.0000"; -.0005" up to 1.5" diameter. Larger diameter "U1", +.000"; -.001".
⁷ Refer to Tapered Bushed designs if driven shaft varies from "U" dimensions offered above. (Frames 32 - 35 only).
⁸ For details of the torque arm kit, refer to pages B-114 and B-115.

Combined Finished Bore Hollow Shaft OtN32 - 35 and OtN26 - 28

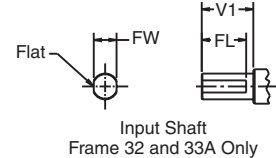
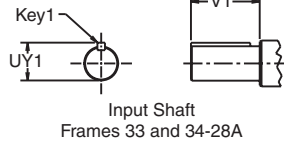
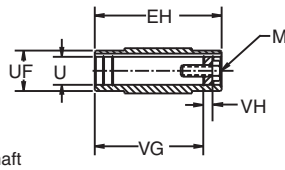
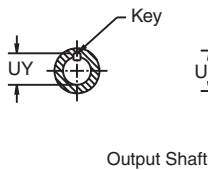
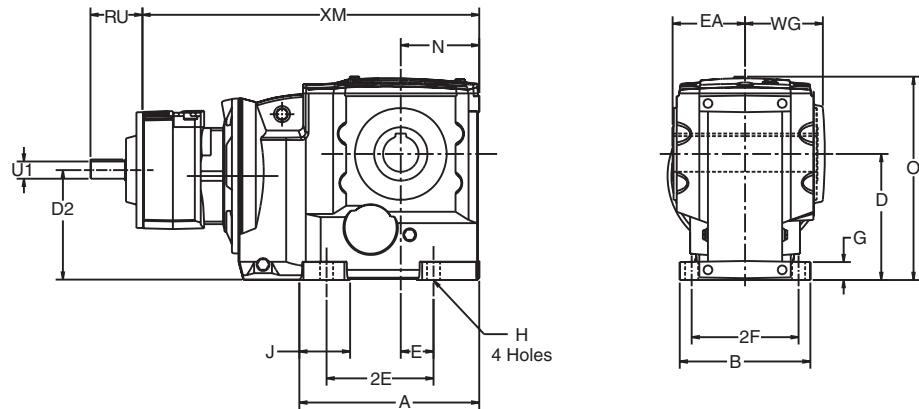

OtN Series

Gear Frame	Version	A	B	D ¹	D2	E	2E	2F	G	H	J	O	N	WG	XM
32	S2	7.81	5.71	4.41	4.06	1.38	5.12	4.71	.73	.43	2.34	8.09	3.03	3.22	14.49
33,33A	S2	8.50	6.61	5.51	4.91	1.18	4.72	5.51	.85	.55	2.86	9.69	3.54	3.73	19.90 ⁷
34	S2	10.13	7.87	7.09	5.57	1.57	5.91	6.50	1.07	.71	2.67	12.05	4.49	4.66	21.55
35	S2	11.92	8.66	8.35	6.56	2.17	7.09	7.09	1.18	.87	3.45	13.58	5.20	5.15	23.87
26A	S1	16.73	11.42	8.86	7.66	6.99	13.98	9.45	1.57	.87	3.54	16.65	8.74	6.97	30.80
27A	S1	19.29	12.60	9.84	7.89	8.27	16.54	10.63	1.77	.94	3.94	18.50	10.04	7.72	31.47
28A	S1	23.23	16.14	12.40	10.40	10.04	20.08	13.78	1.97	1.02	4.33	23.70	12.01	9.49	37.49

Output Shaft

Gear Frame	Version	EA	EH	U ^{4,8}	UF	UY	VG	VH	Key ⁵	M
32	S2	2.98	5.95	1.375	1.96	1.523	5.20	.55	5/16 X 5/16 X 1 13/16	1/2-13 X 1.00
33,33A	S2	3.47	6.94	1.500	2.16	1.674	5.96	.55	3/8 X 3/8 X 2 1/4	5/8-11 X 1.75
34	S2	4.49	8.97	2.000	2.56	2.210	7.44	.79	1/2 X 7/16 X 2 5/8	5/8-11 X 1.75
35	S2	4.83	9.66	2.375	3.54	2.656	8.15	.94	5/8 X 5/8 X 3 5/8	3/4-10 X 2.00
26A	S1	6.10	12.20	2.750	3.35	3.027	10.25	.91	5/8 Sq.	3/4-10
27A	S1	6.70	13.40	3.125	3.75	3.454	11.40	.91	3/4 Sq.	3/4-10
28A	S1	8.45	16.90	3.625	4.35	4.009	14.95	1.02	7/8 Sq.	1-8

Input Shaft

Gear Frame	Version	RU	U1 ⁶	FL	FW	UY1	V1	Key1
32,33A	S2	3.60	.500	.86	.46	-	1.00	-
33	S2	3.17	.625	-	-	.705	1.25	3/16 Sq.
34	S2	3.17	.625	-	-	.705	1.25	3/16 Sq.
35	S2	3.17	.625	-	-	.705	1.25	3/16 Sq.
26A	S1	4.75	1.125	-	-	1.236	2.25	1/4 Sq.
27A	S1	4.75	1.125	-	-	1.236	2.25	1/4 Sq.
28A	S1	5.03	1.125	-	-	1.236	2.25	1/4 Sq.

¹ Dimension "D" will never be exceeded, but may vary from values shown. When exact dimensions are required, shims up to .03" may be necessary.
² All rough casting dimensions may vary by .25" due to casting variations.
³ Driven shaft entry can be from either side of the gear reducer housing by reversing positioning of the snap rings and washer illustrated.
⁴ Output finished bore tolerance: +.0020", -.0000 for all diameters.
⁵ Output key supplied only on frame 34 in "S2" version.
⁶ Input shaft extension tolerances: +.0000"; -.0005" up to 1.5" diameter. Larger diameter "U1", +.000"; -.001".
⁷ XM dimension when gear frame 33A is used will be 16.42.
⁸ Refer to Tapered Bushed designs if driven shaft varies from "U" dimensions offered above. (Frames 32 - 35 only).
⁹ For details of the torque arm kit, refer to pages B-114 and B-115.

3-Stage Finished Bore Hollow Shaft Face Mount OtN32 - 35

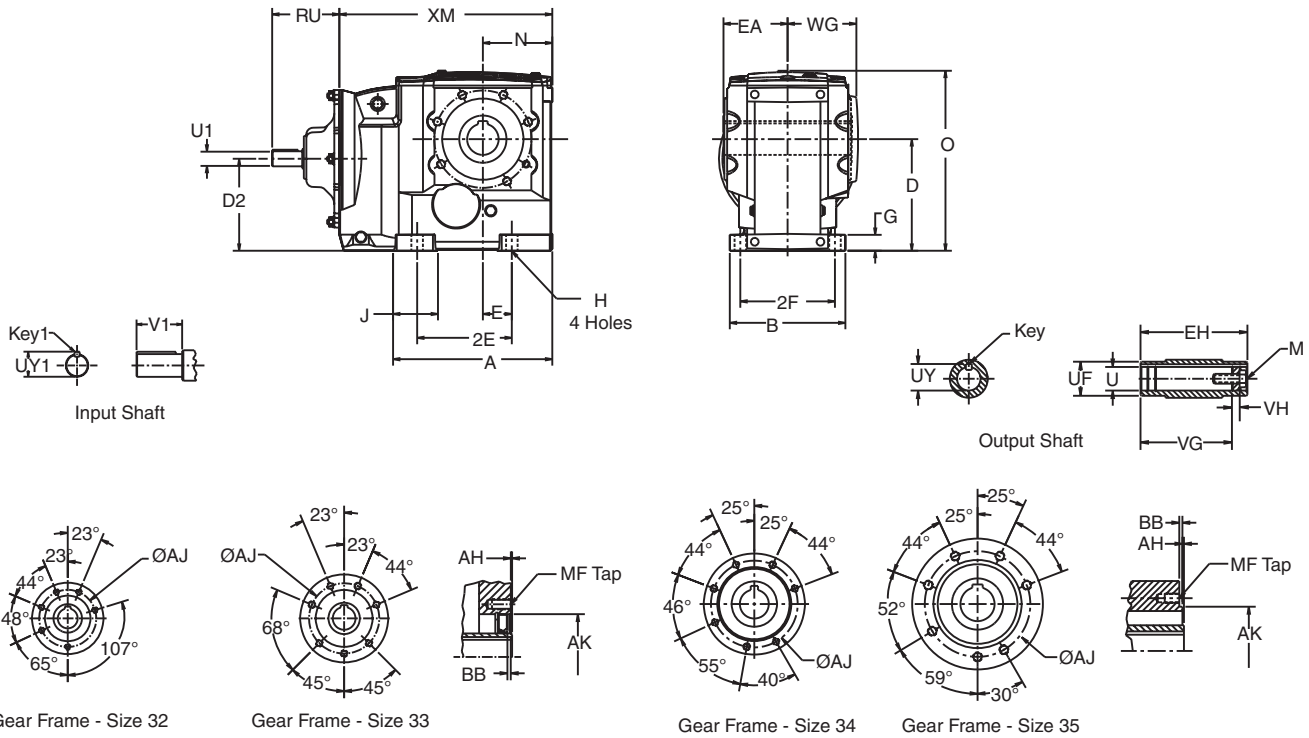

Gear Frame	Version	A	B	D ¹	D2	E	2E	2F	G	H	J	O	N	WG	XM
32	S2	7.81	5.71	4.41	3.78	1.38	5.12	4.71	.73	.43	2.34	8.09	3.03	3.15	10.04
33	S2	8.50	6.61	5.51	5.24	1.18	4.72	5.51	.85	.55	2.86	9.69	3.54	3.63	11.97
34	S2	10.13	7.87	7.09	5.90	1.57	5.91	6.50	1.07	.71	2.67	12.05	4.49	4.66	13.78
35	S2	11.92	8.66	8.35	6.89	2.17	7.09	7.09	1.18	.87	3.45	13.58	5.20	5.15	15.95

Face Mount

Gear Frame	Version	AH	AJ	AK	BB	MF
32	S2	.12	3.94	3.15	.16	M10 X .87
33	S2	.12	4.84	3.94	.16	M12 X .87
34	S2	.14	5.98	5.12	.28	M10 X .87
35	S2	.13	7.48	6.10	.28	M12 X .87

Output Shaft

Gear Frame	Version	EA	EH	U ⁴	UF	UY	VG	VH	Key ⁵	M
32	S2	2.98	5.95	1.375	1.96	1.523	5.20	.55	5/16 X 5/16 X 1 13/16	1/2-13 X 1.00
33	S2	3.47	6.94	1.500	2.16	1.674	5.96	.55	3/8 X 3/8 X 2 1/4	5/8-11 X 1.75
34	S2	4.49	8.97	2.000	2.56	2.210	7.44	.79	1/2 X 7/16 X 2 5/8	5/8-11 X 1.75
35	S2	4.83	9.66	2.375	3.54	2.656	8.15	.94	5/8 X 5/8 X 3 5/8	3/4-10 X 2.00

Input Shaft

Gear Frame	Version	RU	U1 ⁶	UY1	V1	Key1
32	S2	3.17	.625	.705	1.25	3/16 Sq.
33	S2	3.17	.625	.705	1.25	3/16 Sq.
34	S2	4.75	1.125	1.236	2.25	1/4 Sq.
35	S2	5.03	1.125	1.236	2.25	1/4 Sq.

¹ Dimension "D" will never be exceeded, but may vary from values shown. When exact dimensions are required, shims up to .03" may be necessary.
² All rough casting dimensions may vary by .25" due to casting variations.
³ Driven shaft entry can be from either side of the gear reducer housing by reversing positioning of the snap rings and washer illustrated.
⁴ Output finished bore tolerance: +.0020", -.0000 for all diameters.
⁵ Output key supplied only on frame 34 in "S2" version.
⁶ Input shaft extension tolerances: +.0000"; -.0005" up to 1.5" diameter. Larger diameter "U1", +.000"; -.001".

3-Stage Finished Bore Hollow Shaft Face Mount OtN26 - 28

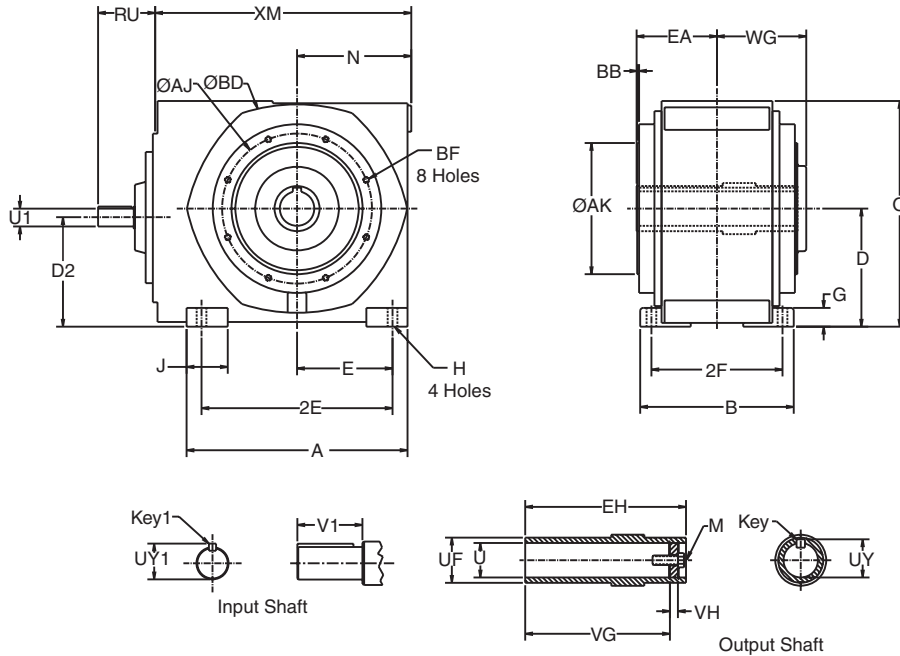

OtN Series

Gear Frame	Version	A	B	D ¹	D2	E	2E	2F	G	H	J	O	N	WG	XM
26	S1	16.73	11.42	8.86	8.43	6.99	13.98	9.45	1.57	.87	3.54	16.65	8.74	6.97	20.15
27	S1	19.29	12.60	9.84	8.66	8.27	16.54	10.63	1.77	.94	3.94	18.50	10.04	7.72	22.24
28	S1	23.23	16.14	12.40	11.42	10.04	20.08	13.78	1.97	1.02	4.33	23.70	12.01	9.49	27.16

Face Mount

Gear Frame	Version	AJ	AK	BB	BD	BF
26	S1	11.81	9.84	.20	13.78	M16 X 22
27	S1	13.78	11.81	.20	15.75	M16 X 22
28	S1	15.75	13.78	.20	17.72	M16 X 22

Output Shaft

Gear Frame	Version	EA	EH	U ⁴	UF	UY	VG	VH	Key	M
26	S1	6.10	12.20	2.750	3.35	3.027	10.25	.91	5/8 Sq.	3/4-10
27	S1	6.70	13.40	3.125	3.75	3.454	11.40	.91	3/4 Sq.	3/4-10
28	S1	8.45	16.90	3.625	4.35	4.009	14.95	1.02	7/8 Sq.	1-8

Input Shaft

Gear Frame	Version	RU	U1 ⁶	UY1	V1	Key1
26	S1	6.49	1.375	1.513	2.75	5/16 Sq.
27	S1	5.76	1.875	2.091	3.75	1/2 Sq.
28	S1	7.11	2.375	2.646	4.75	5/8 Sq.

¹ Dimension "D" will never be exceeded, but may vary from values shown. When exact dimensions are required, shims up to .03" may be necessary.

² All rough casting dimensions may vary by .25" due to casting variations.

³ Driven shaft entry can be from either side of the gear reducer housing by reversing positioning of the snap rings and washer illustrated.

⁴ Output finished bore tolerance: +.0020", -.0000 for all diameters.

⁶ Input shaft extension tolerances: +.0000"; -.0005" up to 1.5" diameter. Larger diameter "U1", +.000"; -.001".

Combined Finished Bore Hollow Shaft Face Mount OtN32 - 35

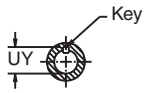
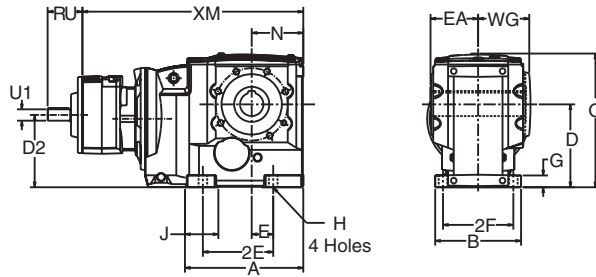

Output Shaft

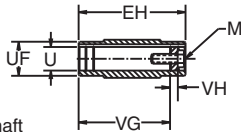

Input Shaft
Frames 33, 34 and 35

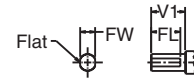

Input Shaft
Frame 32 and 33A Only

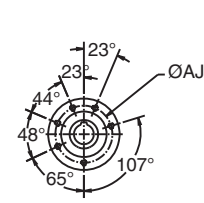

Gear Frame - Size 32

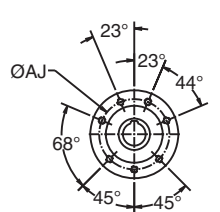

Gear Frame - Size 33

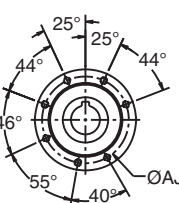
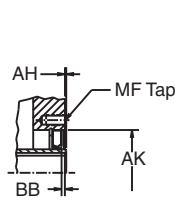

Gear Frame - Size 34

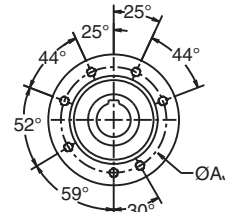

Gear Frame - Size 35

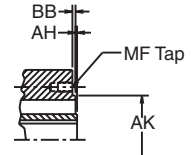

Gear Frame	Version	A	B	D ¹	D2	E	2E	2F	G	H	J	O	N	WG	XM
32	S2	7.81	5.71	4.41	4.06	1.38	5.12	4.71	.73	.43	2.34	8.09	3.03	3.15	14.49
33,33A	S2	8.50	6.61	5.51	4.91	1.18	4.72	5.51	.85	.55	2.86	9.69	3.54	3.63	19.90 ⁷
34	S2	10.13	7.87	7.09	5.57	1.57	5.91	6.50	1.07	.71	2.67	12.05	4.49	4.66	21.55
35	S2	11.92	8.66	8.35	6.56	2.17	7.09	7.09	1.18	.87	3.45	13.58	5.20	5.15	23.87

Face Mount

Gear Frame	Version	AH	AJ	AK	BB	MF
32	S2	.12	3.94	3.15	.16	M10 X .87
33,33A	S2	.12	4.84	3.94	.16	M12 X .87
34	S2	.14	5.98	5.12	.28	M10 X .87
35	S2	.13	7.48	6.10	.28	M12 X .87

Output Shaft

Gear Frame	Version	EA	EH	U ⁴	UF	UY	VG	VH	Key ⁵	M
32	S2	2.98	5.95	1.375	1.96	1.523	5.20	.55	5/16 X 5/16 X 1 13/16	1/2-13 X 1.00
33,33A	S2	3.47	6.94	1.500	2.16	1.674	5.96	.55	3/8 X 3/8 X 2 1/4	5/8-11 X 1.75
34	S2	4.49	8.97	2.000	2.56	2.210	7.44	.79	1/2 X 7/16 X 2 5/8	5/8-11 X 1.75
35	S2	4.83	9.66	2.375	3.54	2.656	8.15	.94	5/8 X 5/8 X 3 5/8	3/4-10 X 2.00

Input Shaft

Gear Frame	Version	RU	U1 ⁶	FL	FW	UY1	V1	Key1
32,33A	S2	3.60	.500	.86	.46	-	1.00	-
33	S2	3.17	.625	-	-	.705	1.25	3/16 Sq.
34	S2	3.17	.625	-	-	.705	1.25	3/16 Sq.
35	S2	3.17	.625	-	-	.705	1.25	3/16 Sq.

¹ Dimension "D" will never be exceeded, but may vary from values shown. When exact dimensions are required, shims up to .03" may be necessary.

² All rough casting dimensions may vary by .25" due to casting variations.

³ Driven shaft entry can be from either side of the gear reducer housing by reversing positioning of the snap rings and washer illustrated.

⁴ Output finished bore tolerance: +.0020", -.0000 for all diameters.

⁵ Output key supplied only on frame 34 in "S2" version.

⁶ Input shaft extension tolerances: +.0000"; -.0005" up to 1.5" diameter. Larger diameter "U1", +.000"; -.001".

⁷ XM dimension when gear frame 33A is used will be 16.42.

Combined Finished Bore Hollow Shaft Face Mount OtN26 - 28

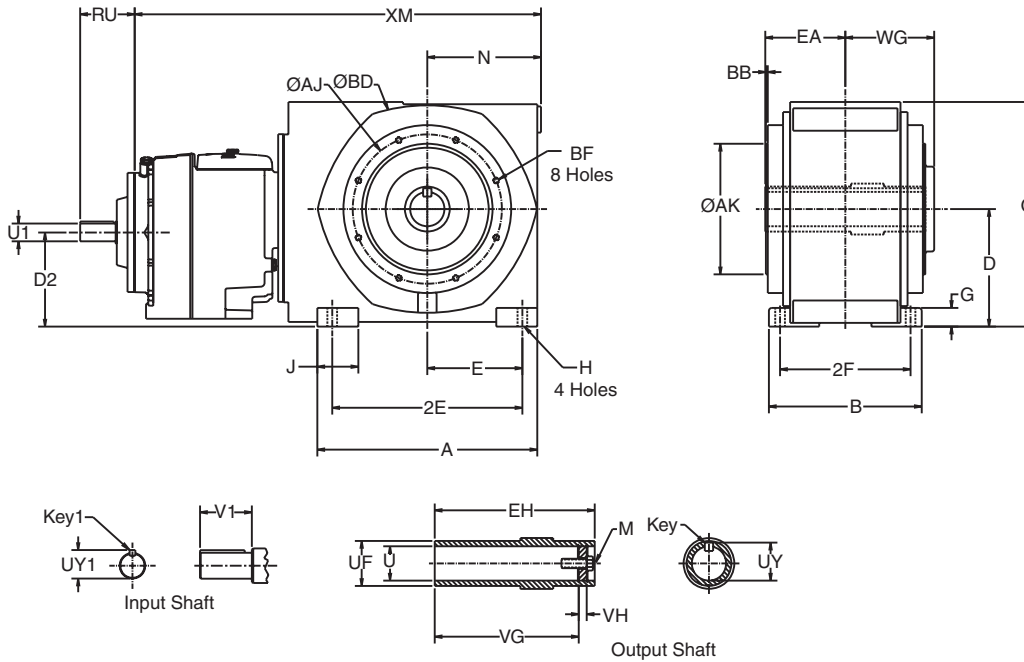

OtN Series

Gear Frame	Version	A	B	D ¹	D2	E	2E	2F	G	H	J	O	N	WG	XM
26A	S1	16.73	11.42	8.86	7.66	6.99	13.98	9.45	1.57	.87	3.54	16.65	8.74	6.97	30.80
27A	S1	19.29	12.60	9.84	7.89	8.27	16.54	10.63	1.77	.94	3.94	18.50	10.04	7.72	31.47
28A	S1	23.23	16.14	12.40	10.40	10.04	20.08	13.78	1.97	1.02	4.33	23.70	12.01	9.49	37.49

Face Mount

Gear Frame	Version	AJ	AK	BB	BD	BF
26A	S1	11.81	9.84	.20	13.78	M16 X 22
27A	S1	13.78	11.81	.20	15.75	M16 X 22
28A	S1	15.75	13.78	.20	17.72	M16 X 22

Output Shaft

Gear Frame	Version	EA	EH	U ⁴	UF	UY	VG	VH	Key	M
26A	S1	6.10	12.20	2.750	3.35	3.027	10.25	.91	5/8 Sq.	3/4-10
27A	S1	6.70	13.40	3.125	3.75	3.454	11.40	.91	3/4 Sq.	3/4-10
28A	S1	8.45	16.90	3.625	4.35	4.009	14.95	1.02	7/8 Sq.	1-8

Input Shaft

Gear Frame	Version	RU	U ⁶	UY1	V1	Key1
26A	S1	4.75	1.125	1.236	2.25	1/4 Sq.
27A	S1	4.75	1.125	1.236	2.25	1/4 Sq.
28A	S1	5.03	1.125	1.236	2.25	1/4 Sq.

¹ Dimension "D" will never be exceeded, but may vary from values shown. When exact dimensions are required, shims up to .03" may be necessary.
² All rough casting dimensions may vary by .25" due to casting variations.
³ Driven shaft entry can be from either side of the gear reducer housing by reversing positioning of the snap rings and washer illustrated.
⁴ Output finished bore tolerance: +.0020", -.0000 for all diameters.
⁶ Input shaft extension tolerances: +.0000"; -.0005" up to 1.5" diameter. Larger diameter "U1", +.000"; -.001".

3-Stage Finished Bore Hollow Shaft Flange Mount OtN32 - 35

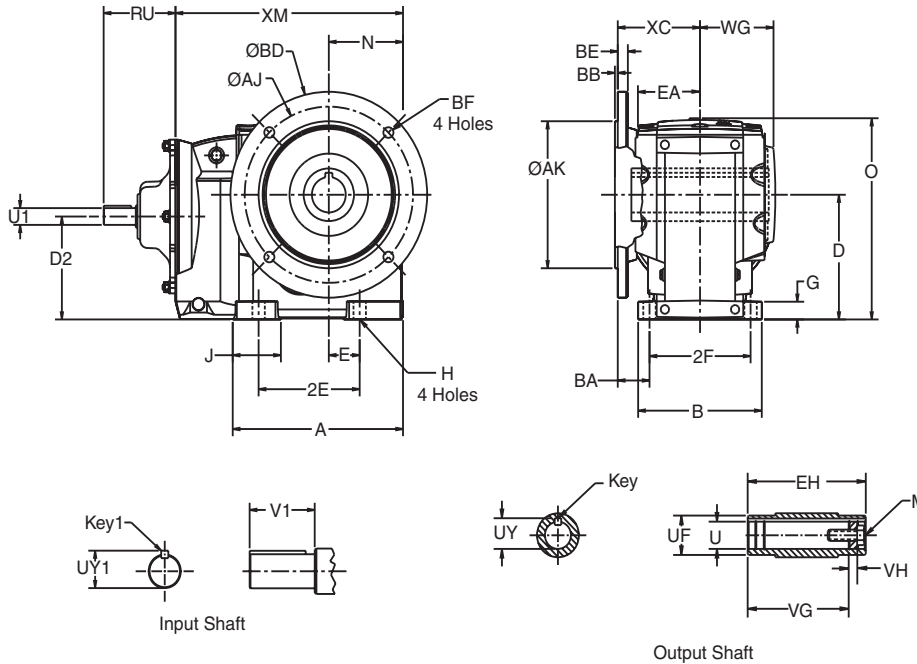

Gear Frame	Version	A	B	D'	D2	E	2E	2F	G	H	J	O	N	BA	WG	XC	XM
32	S2	7.81	5.71	4.41	3.78	1.38	5.12	4.71	.73	.43	2.34	8.09	3.03	1.81	3.22	4.04	10.04
33	S2	8.50	6.61	5.51	5.24	1.18	4.72	5.51	.85	.55	2.86	9.69	3.54	2.08	3.73	4.84	11.97
34	S2	10.13	7.87	7.09	5.90	1.57	5.91	6.50	1.07	.71	2.67	12.05	4.49	1.93	4.66	5.18	13.78
35	S2	11.92	8.66	8.35	6.89	2.17	7.09	7.09	1.18	.87	3.45	13.58	5.20	2.22	5.15	5.77	15.95

Output Shaft

Gear Frame	Version	EA	EH	U ⁴	UF	UY	VG	VH	Key ⁵	M
32	S2	2.98	5.95	1.375	1.96	1.523	5.20	.55	5/16 X 5/16 X 1 13/16	1/2-13 X 1.00
33	S2	3.47	6.94	1.500	2.16	1.674	5.96	.55	3/8 X 3/8 X 2 1/4	5/8-11 X 1.75
34	S2	4.49	8.97	2.000	2.56	2.210	7.44	.79	1/2 X 7/16 X 2 5/8	5/8-11 X 1.75
35	S2	4.83	9.66	2.375	3.54	2.656	8.15	.94	5/8 X 5/8 X 3 5/8	3/4-10 X 2.00

Output Flange

Gear Frame	Flange Code	AK	AJ	BB	BD	BE	BF
32	5	5.118	6.50	.14	7.87	.39	.47
	6	7.087	8.46	.16	9.84	.47	.55
33	5	7.087	8.46	.16	9.84	.47	.55
	6	9.055	10.43	.16	11.81	.47	.55
34	5	9.055	10.43	.16	11.81	.59	.55
	6	9.842	11.80	.16	13.77	.59	.71
35	5	9.842	11.80	.20	13.77	.71	.71
	6	11.810	13.77	.20	15.75	.71	.71

Input Shaft

Gear Frame	Version	RU	U1 ⁶	UY1	V1	Key1
32	S2	3.17	.625	.705	1.25	3/16 Sq.
33	S2	3.17	.625	.705	1.25	3/16 Sq.
34	S2	4.75	1.125	1.236	2.25	1/4 Sq.
35	S2	5.03	1.125	1.236	2.25	1/4 Sq.

¹ Dimension "D" will never be exceeded, but may vary from values shown. When exact dimensions are required, shims up to .03" may be necessary.

² All rough casting dimensions may vary by .25" due to casting variations.

³ Driven shaft entry can be from either side of the gear reducer housing by reversing positioning of the snap rings and washer illustrated.

⁴ Output finished bore tolerance: +.0020", -.0000 for all diameters.

⁵ Output key supplied only on frame 34 in "S2" version.

⁶ Input shaft extension tolerances: +.0000"; -.0005" up to 1.5" diameter. Larger diameter "U1", +.000"; -.001".

3-Stage Finished Bore Hollow Shaft Flange Mount OtN26 - 28

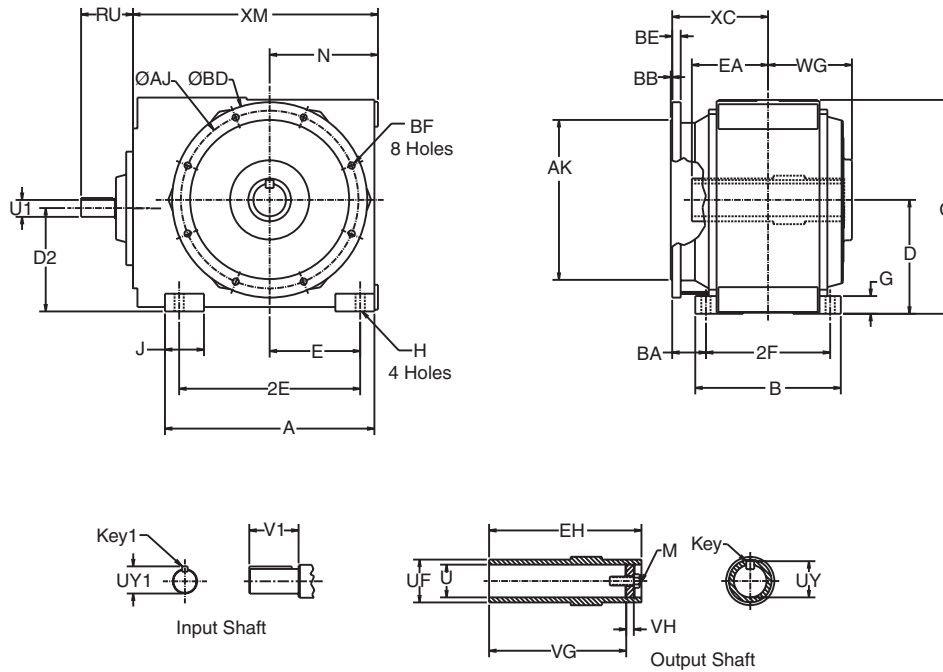

OtN Series

Gear Frame	Version	A	B	D ¹	D2	E	2E	2F	G	H	J	O	N	BA	WG	XC	XM
26	S1	16.73	11.42	8.86	8.43	6.99	13.98	9.45	1.57	.87	3.54	16.65	8.74	3.54	6.97	9.00	20.15
27	S1	19.29	12.60	9.84	8.66	8.27	16.54	10.63	1.77	.94	3.94	18.50	10.04	3.54	7.72	8.55	22.24
28	S1	23.23	16.14	12.40	11.42	10.04	20.08	13.78	1.97	1.02	4.33	23.70	12.01	3.74	9.49	11.51	27.16

Output Shaft

Gear Frame	Version	EA	EH	U ⁵	UF	UY	VG	VH	Key ⁴	M
26	S1	6.10	12.20	2.750	3.35	3.027	10.25	.91	5/8 Sq.	3/4-10
27	S1	6.70	13.40	3.125	3.75	3.454	11.40	.91	3/4 Sq.	3/4-10
28	S1	8.45	16.90	3.625	4.35	4.009	14.95	1.02	7/8 Sq.	1-8

Output Flange

Gear Frame	Flange Code	AJ	AK	BB	BD	BE	BF
26	5	15.75	13.75	.20	17.72	.79	.71
27	5	15.75	13.78	.20	17.72	.79	.71
28	5	19.69	17.72	.24	21.65	.94	.71

Input Shaft

Gear Frame	Version	RU	U1 ⁶	UY1	V1	Key1
26	S1	6.49	1.375	1.513	2.75	5/16 Sq.
27	S1	5.76	1.875	2.091	3.75	1/2 Sq.
28	S1	7.11	2.375	2.646	4.75	5/8 Sq.

¹ Dimension "D" will never be exceeded, but may vary from values shown. When exact dimensions are required, shims up to .03" may be necessary.
² All rough casting dimensions may vary by .25" due to casting variations.
³ Driven shaft entry can be from either side of the gear reducer housing by reversing positioning of the snap rings and washer illustrated.

⁴ Output key supplied only on frame 34 in "S2" version.
⁵ Output finished bore tolerance: +.0020", -.0000 for all diameters.
⁶ Input shaft extension tolerances: +.0000"; -.0005" up to 1.5" diameter. Larger diameter "U1", +.000"; -.001".

Combined Finished Bore Hollow Shaft Flange Mount OtN32 - 35

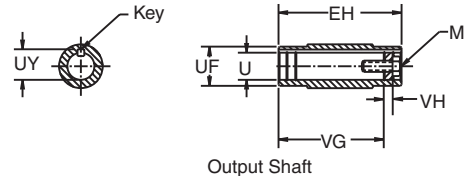
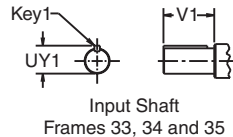
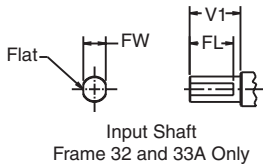
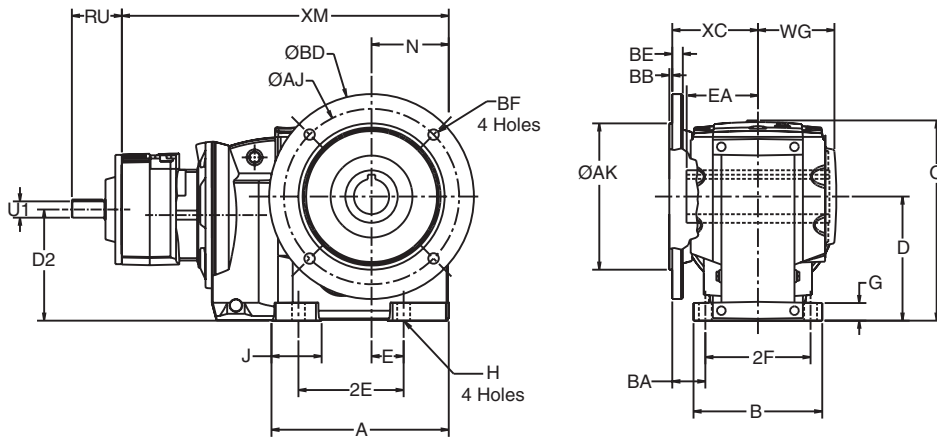

Gear Frame	Version	A	B	D ¹	D ₂	E	2E	2F	G	H	J	O	N	BA	WG	XC	XM
32	S2	7.81	5.71	4.41	4.06	1.38	5.12	4.71	.73	.43	2.34	8.09	3.03	1.81	3.22	4.04	14.49
33,33A	S2	8.50	6.61	5.51	4.91	1.18	4.72	5.51	.85	.55	2.86	9.69	3.54	2.08	3.73	4.84	19.90 ⁷
34	S2	10.13	7.87	7.09	5.57	1.57	5.91	6.50	1.07	.71	2.67	12.05	4.49	1.93	4.66	5.18	21.55
35	S2	11.92	8.66	8.35	6.56	2.17	7.09	7.09	1.18	.87	3.45	13.58	5.20	2.22	5.15	5.77	23.87

Output Shaft

Gear Frame	Version	EA	EH	U ⁵	UF	UY	VG	VH	Key ⁴	M
32	S2	2.98	5.95	1.375	1.96	1.523	5.20	.55	5/16 X 5/16 X 1 13/16	1/2-13 X 1.00
33,33A	S2	3.47	6.94	1.500	2.16	1.674	5.96	.55	3/8 X 3/8 X 2 1/4	5/8-11 X 1.75
34	S2	4.49	8.97	2.000	2.56	2.210	7.44	.79	1/2 X 7/16 X 2 5/8	5/8-11 X 1.75
35	S2	4.83	9.66	2.375	3.54	2.656	8.15	.94	5/8 X 5/8 X 3 5/8	3/4-10 X 2.00

Output Flange

Gear Frame	Flange Code	AK	AJ	BB	BD	BE	BF
32	5	5.118	6.50	.14	7.87	.39	.47
	6	7.087	8.46	.16	9.84	.47	.55
33,33A	5	7.087	8.46	.16	9.84	.47	.55
	6	9.055	10.43	.16	11.81	.47	.55
34	5	9.055	10.43	.16	11.81	.59	.55
	6	9.842	11.80	.16	13.77	.59	.71
35	5	9.842	11.80	.20	13.77	.71	.71
	6	11.810	13.77	.20	15.75	.71	.71

Input Shaft

Gear Frame	Version	RU	U ⁶	FL	FW	UY1	V1	Key1
32,33A	S2	3.60	.500	.86	.46	-	1.00	-
33	S2	3.17	.625	-	-	.705	1.25	3/16 Sq.
34	S2	3.17	.625	-	-	.705	1.25	3/16 Sq.
35	S2	3.17	.625	-	-	.705	1.25	3/16 Sq.

¹ Dimension "D" will never be exceeded, but may vary from values shown. When exact dimensions are required, shims up to .03" may be necessary.
² All rough casting dimensions may vary by .25" due to casting variations.
³ Driven shaft entry can be from either side of the gear reducer housing by reversing positioning of the snap rings and washer illustrated.

⁴ Output key supplied only on frame 34 in "S2" version.
⁵ Output finished bore tolerance: +.0020", -.0000 for all diameters.
⁶ Input shaft extension tolerances: +.0000"; -.0005" up to 1.5" diameter. Larger diameter "U1", +.000"; -.001".
⁷ XM dimension when gear frame 33A is used will be 16.42.

Combined Finished Bore Hollow Shaft Flange Mount OtN26 - 28

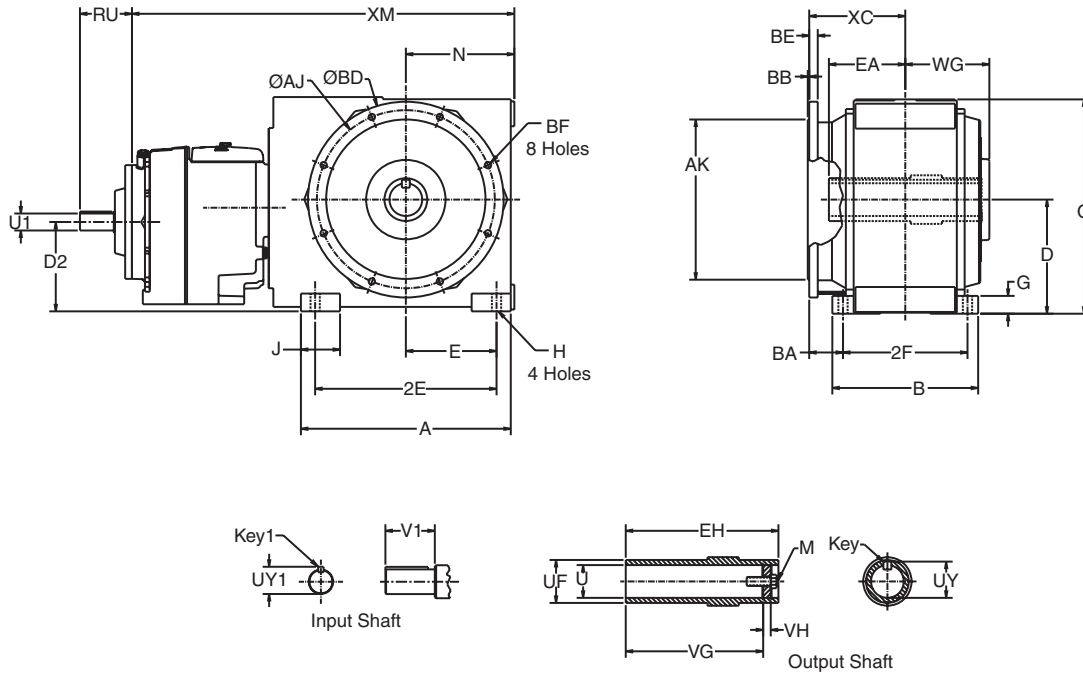

OtN Series

Gear Frame	Version	A	B	D ¹	D2	E	2E	2F	G	H	J	O	N	BA	WG	XC	XM
26A	S1	16.73	11.42	8.86	7.66	6.99	13.98	9.45	1.57	.87	3.54	16.65	8.74	3.54	6.97	9.00	30.80
27A	S1	19.29	12.60	9.84	7.89	8.27	16.54	10.63	1.77	.94	3.94	18.50	10.04	3.54	7.72	8.55	31.47
28A	S1	23.23	16.14	12.40	10.40	10.04	20.08	13.78	1.97	1.02	4.33	23.70	12.01	3.74	9.49	11.51	37.49

Output Shaft

Gear Frame	Version	EA	EH	U ⁵	UF	UY	VG	VH	Key ⁴	M
26A	S1	6.10	12.20	2.750	3.35	3.027	10.25	.91	5/8 Sq.	3/4-10
27A	S1	6.70	13.40	3.125	3.75	3.454	11.40	.91	3/4 Sq.	3/4-10
28A	S1	8.45	16.90	3.625	4.35	4.009	14.95	1.02	7/8 Sq.	1-8

Output Flange

Gear Frame	Flange Code	AJ	AK	BB	BD	BE	BF
26A	5	15.75	13.75	.20	17.72	.79	.71
27A	5	15.75	13.78	.20	17.72	.79	.71
28A	5	19.69	17.72	.24	21.65	.94	.71

Input Shaft

Gear Frame	Version	RU	U1 ⁶	UY1	V1	Key1
26A	S1	4.75	1.125	1.236	2.25	1/4 Sq.
27A	S1	4.75	1.125	1.236	2.25	1/4 Sq.
28A	S1	5.03	1.125	1.236	2.25	1/4 Sq.

¹ Dimension "D" will never be exceeded, but may vary from values shown. When exact dimensions are required, shims up to .03" may be necessary.
² All rough casting dimensions may vary by .25" due to casting variations.
³ Driven shaft entry can be from either side of the gear reducer housing by reversing positioning of the snap rings and washer illustrated.
⁴ Output key supplied only on frame 34 in "S2" version.
⁵ Output finished bore tolerance: +.0020", -.0000 for all diameters.
⁶ Input shaft extension tolerances: +.0000"; -.0005" up to 1.5" diameter. Larger diameter "U1", +.000"; -.001".

3-Stage Taper Bushed Shaft Mount OtN32 - 35

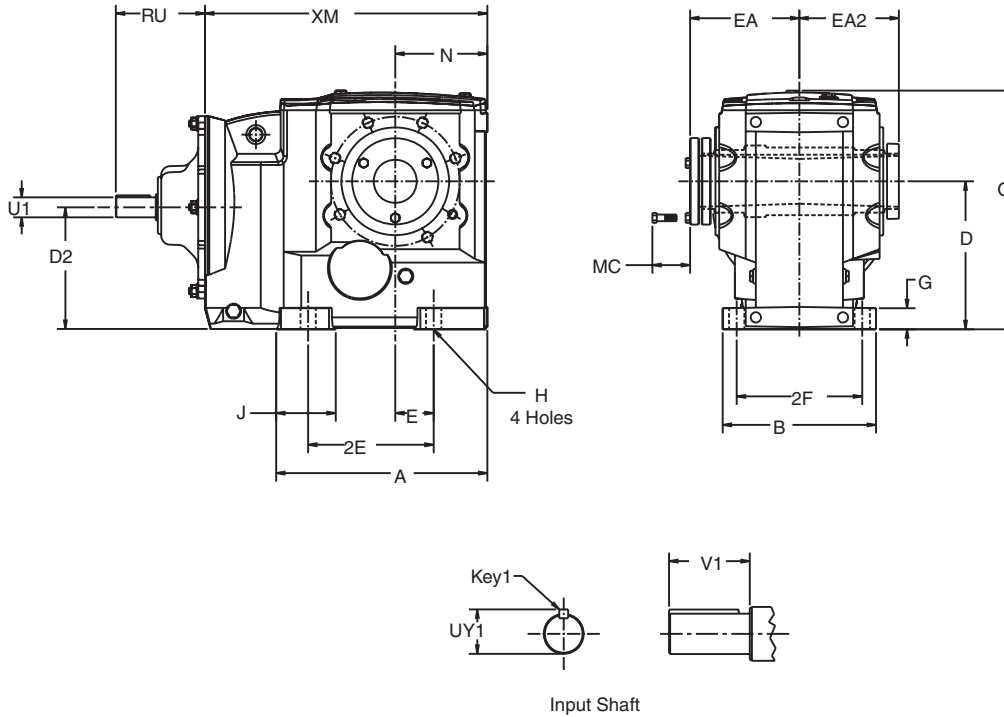

Gear Frame	Version	A	B	D ¹	D2	E	2E	2F	G	H	J	O	N	XM
32	S2	7.81	5.71	4.41	3.78	1.38	5.12	4.71	.73	.43	2.34	8.09	3.03	10.04
33	S2	8.50	6.61	5.51	5.24	1.18	4.72	5.51	.85	.55	2.86	9.69	3.54	11.97
34	S2	10.13	7.87	7.09	5.90	1.57	5.91	6.50	1.07	.71	2.67	12.05	4.49	13.78
35	S2	11.92	8.66	8.35	6.89	2.17	7.09	7.09	1.18	.87	3.45	13.58	5.20	15.95

Output Shaft

Gear Frame	Version	EA	EA2	MC ⁵	Bushing Bores ⁴	
					Min.	Max.
32	S2	4.85	4.27	1.75	3/4	1 7/16
33	S2	4.82	4.23	1.75	3/4	1 7/16
34	S2	5.84	5.27	1.88	15/16	1 15/16
35	S2	6.17	5.620	1.88	1 3/8	2 7/16

Input Shaft

Gear Frame	Version	RU	U1 ³	UY1	V1	Key1
32	S2	3.17	.625	.705	1.25	3/16 Sq.
33	S2	3.17	.625	.705	1.25	3/16 Sq.
34	S2	4.75	1.125	1.236	2.25	1/4 Sq.
35	S2	5.03	1.125	1.236	2.25	1/4 Sq.

¹ Dimension "D" will never be exceeded, but may vary from values shown. When exact dimensions are required, shims up to .03" may be necessary.
² All rough casting dimensions may vary by .25" due to casting variations.
³ Input shaft extension tolerances: +.0000"; -.0005" up to 1.5" diameter. Larger diameter "U1", +.000"; -.001".
⁴ Refer to page B-116 by gear frame for listing of all inch and metric bushing bore sizes available.

⁵ The MC dimension shows spacing required to install or remove the bushing from the reducer.
⁶ Bushing and dust cap can be installed opposite of how they are shown above.
⁷ Driven shaft entry can be from either side of the gear reducer housing. Refer to installation manual for requirements.
⁸ For details of the torque arm kit, refer to page B-22.

Combined Taper Bushed Shaft Mount OtN32 - 35

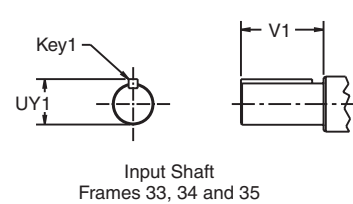
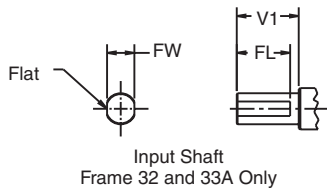
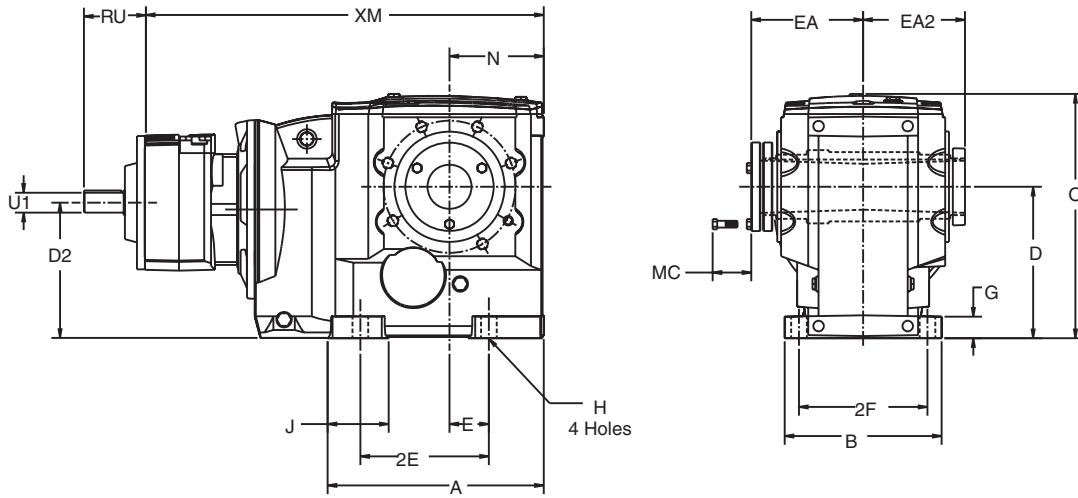

Gear Frame	Version	A	B	D ¹	D2	E	2E	2F	G	H	J	O	N	XM
32	S2	7.81	5.71	4.41	4.06	1.38	5.12	4.71	.73	.43	2.34	8.09	3.03	14.49
33,33A	S2	8.50	6.61	5.51	4.91	1.18	4.72	5.51	.85	.55	2.86	9.69	3.54	19.90 ⁹
34	S2	10.13	7.87	7.09	5.57	1.57	5.91	6.50	1.07	.71	2.67	12.05	4.49	21.55
35	S2	11.92	8.66	8.35	6.56	2.17	7.09	7.09	1.18	.87	3.45	13.58	5.20	23.87

Output Shaft

Gear Frame	Version	EA	EA2	MC ⁵	Bushing Bores ⁴	
					Min.	Max.
32	S2	4.85	4.27	1.75	3/4	1 7/16
33,33A	S2	4.82	4.23	1.75	3/4	1 7/16
34	S2	5.84	5.27	1.88	15/16	1 15/16
35	S2	6.17	5.620	1.88	1 3/8	2 7/16

Input Shaft

Gear Frame	Version	RU	U1 ³	FL	FW	UY1	V1	Key1
32,33A	S2	3.60	.500	.86	.46	-	1.00	-
33	S2	3.17	.625	-	-	.705	1.25	3/16 Sq.
34	S2	3.17	.625	-	-	.705	1.25	3/16 Sq.
35	S2	3.17	.625	-	-	.705	1.25	3/16 Sq.

¹ Dimension "D" will never be exceeded, but may vary from values shown. When exact dimensions are required, shims up to .03" may be necessary.
² All rough casting dimensions may vary by .25" due to casting variations.
³ Input shaft extension tolerances: +.0000"; -.0005" up to 1.5" diameter. Larger diameter "U1", +.000"; -.001".
⁴ Refer to page B-116 by gear frame for listing of all inch and metric bushing bore sizes available.

⁵ The MC dimension shows spacing required to install or remove the bushing from the reducer.
⁶ Bushing and dust cap can be installed opposite of how they are shown above.
⁷ Driven shaft entry can be from either side of the gear reducer housing. Refer to installation manual for requirements.
⁸ For details of the torque arm kit, refer to page B-22.
⁹ XM dimension when gear frame 33A is used will be 16.42.

3-Stage Output Shafted Foot Mount OtN33 - 35

OtN Series

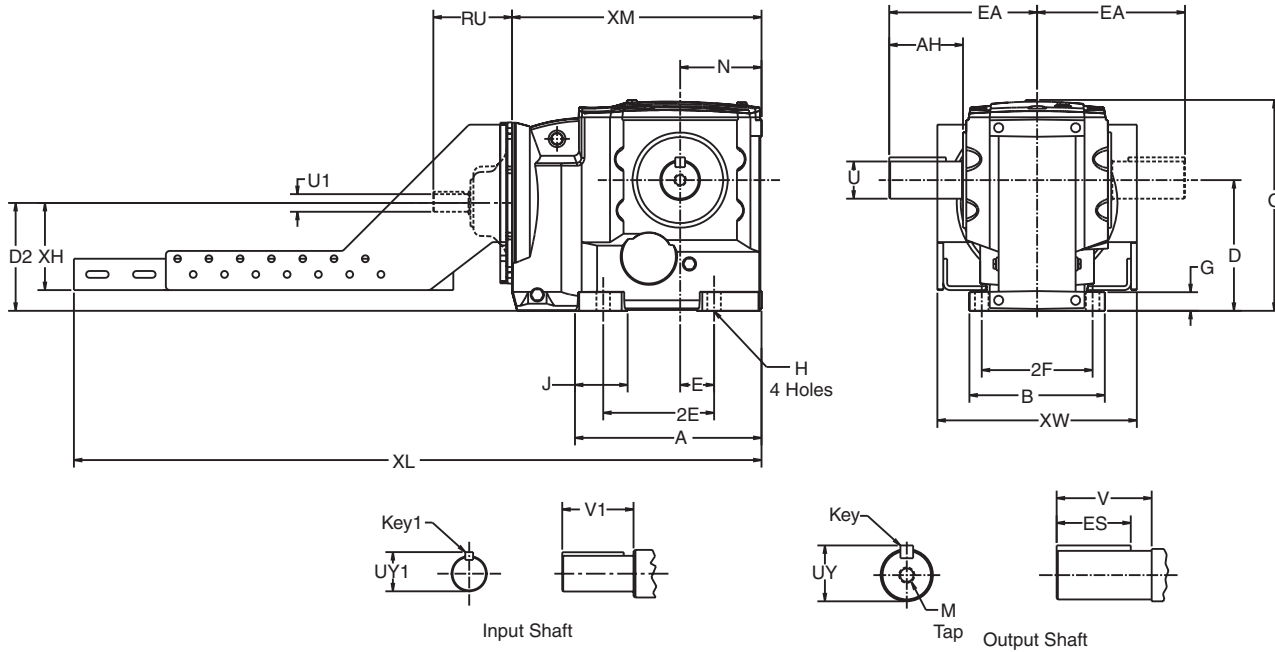

Gear Frame	Version	A	B	D ¹	D2	E	2E	2F	G	H	J	O	N	XM
33	S2	8.50	6.61	5.51	5.24	1.18	4.72	5.51	.85	.55	2.86	9.69	3.54	11.97
	S1	8.08	8.58	4.92	5.20	3.35	6.69	6.10	.79	.55	2.27	10.43	3.54	11.97
34	S2	10.13	7.87	7.09	5.90	1.57	5.91	6.50	1.07	.71	2.67	12.05	4.49	13.78
	S1	10.69	9.60	6.30	7.49	4.53	9.06	7.68	1.18	.71	3.19	13.39	4.49	13.78
35	S2	11.92	8.66	8.35	6.89	2.17	7.09	7.09	1.18	.87	3.37	13.58	5.20	15.95
	S1	13.07	10.98	7.87	9.33	5.51	11.02	9.06	1.40	.87	4.05	16.22	5.20	15.95

Output Shaft

Gear Frame	Version	U ³	UY	V	AH	EA	Key	ES	M
33	S2	1.625	1.783	3.25	3.39	6.73	3/8 Sq.	2.78	5/8-11 X 1.38
	S1	1.500	1.657	3.18	3.19	7.12	3/8 Sq.	2.78	5/8-11 X 1.38
34	S2	2.000	2.210	3.63	3.76	8.11	1/2 Sq.	3.06	3/4-10 X 1.61
	S1	1.750	1.909	3.56	3.66	8.46	3/8 Sq.	3.56	3/4-10 X 1.61
35	S2	2.375	2.638	4.61	4.74	9.45	5/8 Sq.	3.81	3/4-10 X 1.61
	S1	2.375	2.638	5.73	5.27	10.57	5/8 Sq.	4.81	3/4-10 X 1.61

Input Shaft

Gear Frame	Version	RU	U1 ⁴	UY1	V1	Key1
33	S1,S2	3.17	.625	.71	1.25	3/16 Sq.
34	S1,S2	4.75	1.125	1.236	2.25	1/4 Sq.
35	S1,S2	5.03	1.125	1.236	2.25	1/4 Sq.

Motor Frame

Gear Frame	143T-145T			182T-184T			213T-215T		
	XH	XL	XW	XH	XL	XW	XH	XL	XW
33	3.75	30.25	11.38	-	-	-	-	-	-
34	4.74	39.25	12.38	4.74	39.25	12.38	-	-	-
35	5.50	42.61	12.75	5.50	41.61	12.75	5.50	42.01	12.75

¹ Dimension "D" will never be exceeded, but may vary from values shown. When exact dimensions are required, shims up to .03" may be necessary.
² All rough casting dimensions may vary by .25" due to casting variations.

³ Output shaft extension tolerances: +.0000"; -.0005" for shafts up to 1.5" diameter "U". Larger diameter "U", +.000"; -.001".
⁴ Input shaft extension tolerances: +.0000"; -.0005" up to 1.5" diameter. Larger diameter "U1", +.000"; -.001".

Combined Output Shafted Foot Mount OtN26 - 28

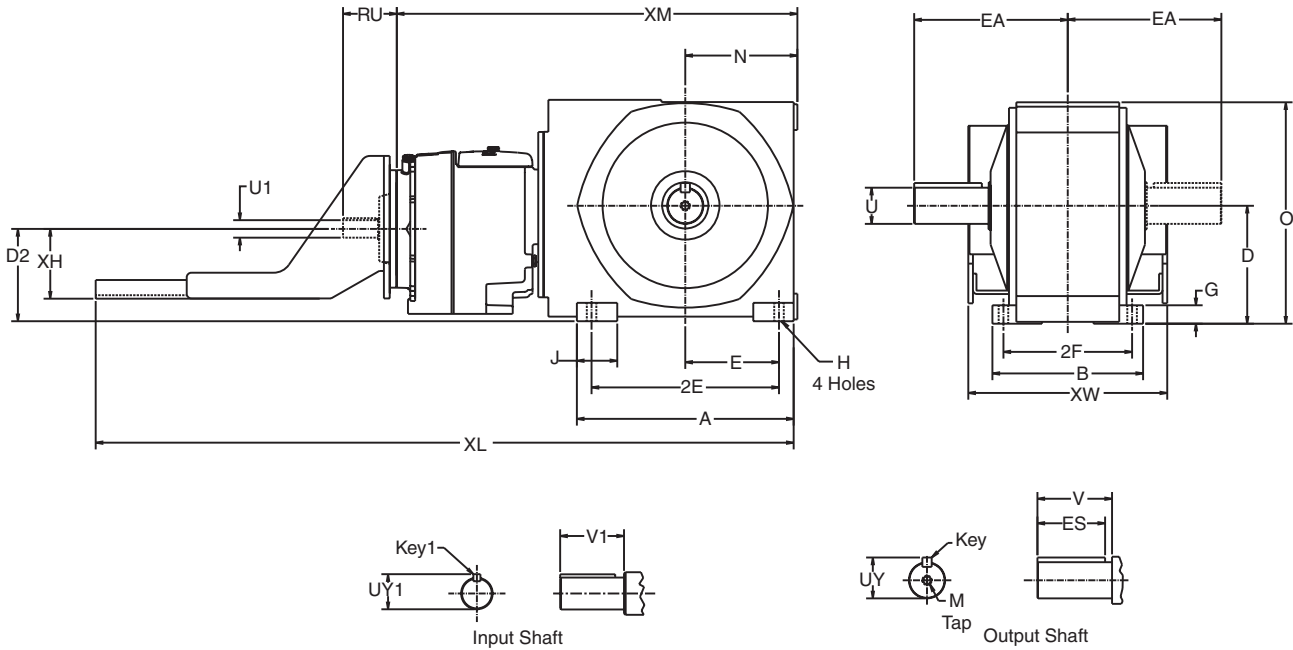

Gear Frame	Version	A	B	D ¹	D2	E	2E	2F	G	H	J	O	N	XM
26A	S1	16.73	11.42	8.86	7.66	6.99	13.98	9.45	1.57	.87	3.54	16.65	8.74	30.80
27A	S1	19.29	12.60	9.84	7.89	8.27	16.54	10.63	1.77	.94	3.94	18.50	10.04	31.47
28A	S1	23.23	16.14	12.40	10.40	10.04	20.08	13.78	1.97	1.02	4.33	23.70	12.01	37.49

Output Shaft

Gear Frame	Version	U ³	UY	V	AH	EA	Key	ES	M
26A	S1	2.875	3.200	5.75	5.91	12.82	3/4 Sq.	5.13	3/4-10 X 1.97
27A	S1	3.500	3.882	7.01	7.33	13.70	7/8 Sq.	6.25	1-8 X 1.97
28A	S1	3.875	4.426	7.99	8.19	17.06	1.00 Sq.	7.25	1-8 X 1.97

Input Shaft

Gear Frame	Version	RU	U1 ⁴	UY1	V1	Key1
26A	S1	4.75	1.125	1.236	2.25	1/4 Sq.
27A	S1	4.75	1.125	1.236	2.25	1/4 Sq.
28A	S1	5.03	1.125	1.236	2.25	1/4 Sq.

Motor Frame

Gear Frame	143T-145T			182T-184T			213T-215T		
	XH	XL	XW	XH	XL	XW	XH	XL	XW
26A	4.74	45.62	12.38	4.74	45.62	12.38	-	-	-
27A	4.74	48.62	12.38	4.74	47.71	12.38	-	-	-
28A	5.50	53.22	12.75	5.50	52.82	12.75	5.50	53.22	12.75

¹ Dimension "D" will never be exceeded, but may vary from values shown. When exact dimensions are required, shims up to .03" may be necessary.

² All rough casting dimensions may vary by .25" due to casting variations.

³ Output shaft extension tolerances: +.0000"; -.0005" for shafts up to 1.5" diameter "U". Larger diameter "U", +.000"; -.001".

⁴ Input shaft extension tolerances: +.0000"; -.0005" up to 1.5" diameter. Larger diameter "U1", +.000"; -.001".

3-Stage Output Shafted Flange Mount OtN33 - 35

OtN Series

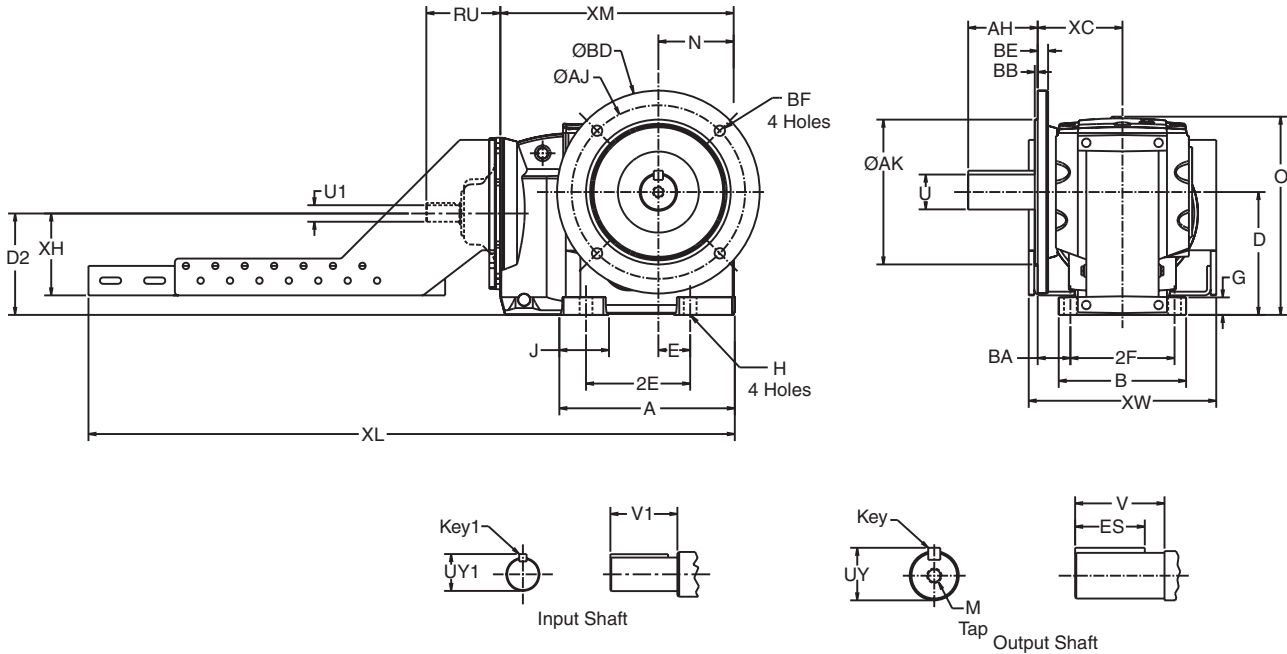

Gear Frame	Version	A	B	D ¹	D2	E	2E	2F	G	H	J	O	N	BA	XC	XM
33	S1,S2	8.50	6.61	5.51	5.24	1.18	4.72	5.51	.85	.55	2.86	9.69	3.54	2.24	4.84	11.97
34	S1,S2	10.13	7.87	7.09	5.90	1.57	5.91	6.50	1.07	.71	2.67	12.05	4.49	1.93	5.18	13.78
35	S2	11.92	8.66	8.35	6.89	2.17	7.09	7.09	1.18	.87	3.45	13.58	5.20	2.22	5.76	15.95

Output Shaft

Gear Frame	Version	U ³	UY	V	AH	Key	ES	M
33	S2	1.625	1.783	3.25	3.38	3/8 Sq.	2.78	5/8-11 X 1.38
	S1	1.500	1.657	3.18	2.28	3/8 Sq.	2.19	5/8-11 X 1.38
34	S2	2.000	2.210	3.94	3.94	1/2 Sq.	3.06	3/4-10 X 1.61
	S1	1.750	1.909	3.56	3.28	3/8 Sq.	3.56	3/4-10 X 1.61
35	S2	2.375	2.638	4.72	4.72	5/8 Sq.	3.81	3/4-10 X 1.61

Output Flange

Gear Frame	Flange Code	AK	AJ	BB	BD	BE	BF
33	5	7.087	8.46	.16	9.84	.47	.55
	6	9.055	10.43	.16	11.81	.47	.55
34	5	9.055	10.43	.16	11.81	.59	.55
	6	9.842	11.80	.16	13.77	.59	.71
35	5	9.842	11.80	.20	13.77	.71	.71
	6	11.810	13.77	.20	15.75	.71	.71

Input Shaft

Gear Frame	Version	RU	U1 ⁴	UY1	V1	Key1
33	S1,S2	3.17	.625	.705	1.25	3/16 Sq.
34	S1,S2	4.75	1.125	1.236	2.25	1/4 Sq.
35	S2	5.03	1.125	1.236	2.25	1/4 Sq.

Motor Frame

Gear Frame	143T-145T			182T-184T			213T-215T		
	XH	XL	XW	XH	XL	XW	XH	XL	XW
33	3.75	30.25	11.38	-	-	-	-	-	-
34	4.74	39.25	12.38	4.74	39.25	12.38	-	-	-
35	5.50	42.61	12.75	5.50	41.61	12.75	5.50	42.01	12.75

¹ Dimension "D" will never be exceeded, but may vary from values shown. When exact dimensions are required, shims up to .03" may be necessary.
² All rough casting dimensions may vary by .25" due to casting variations.

³ Output shaft extension tolerances: +.0000"; -.0005" for shafts up to 1.5" diameter "U". Larger diameter "U", +.000"; -.001".
⁴ Input shaft extension tolerances: +.0000"; -.0005" up to 1.5" diameter. Larger diameter "U1", +.000"; -.001".

3-Stage Output Shafted Flange Mount OtN26 - 28

OtN Series

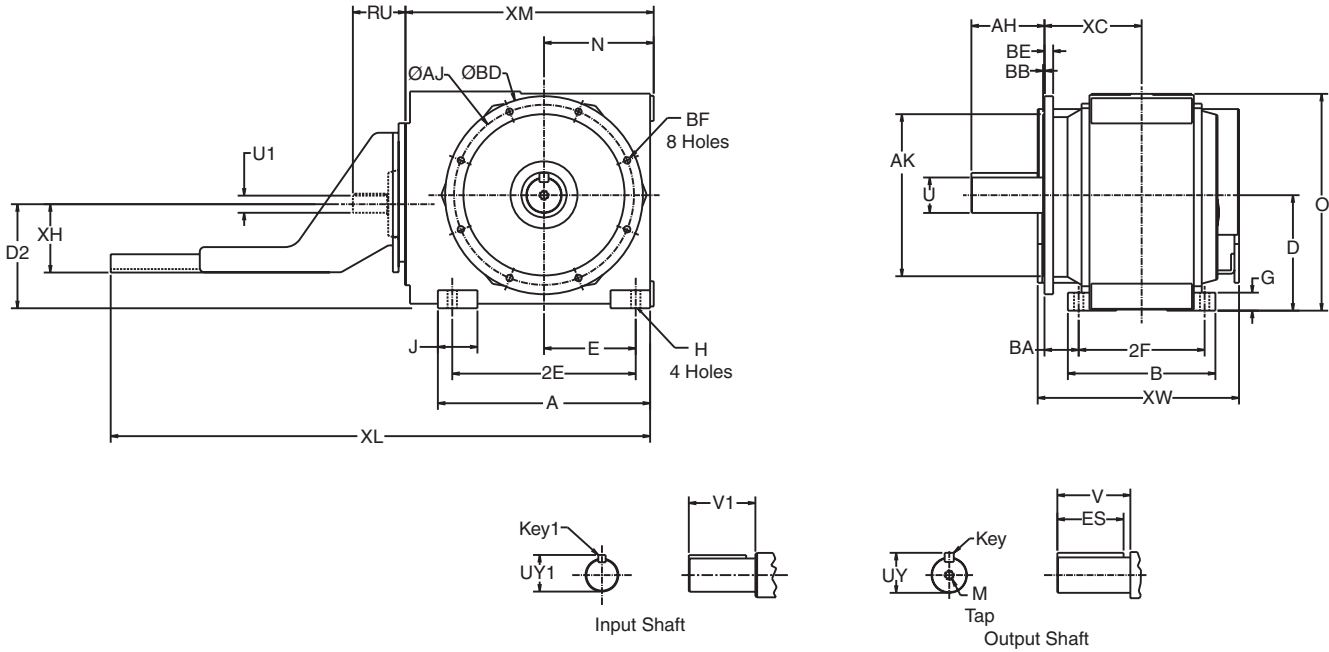

Gear Frame	Version	A	B	D ¹	D2	E	2E	2F	G	H	J	O	N	BA	XC	XM
26	S1	16.73	11.42	8.86	8.43	6.99	13.98	9.45	1.57	.87	3.54	16.65	8.74	3.54	9.00	20.15
27	S1	19.29	12.60	9.84	8.66	8.27	16.54	10.63	1.77	.94	3.94	18.50	10.04	3.54	8.55	22.24
28	S1	23.23	16.14	12.40	11.42	10.04	20.08	13.78	1.97	1.02	4.33	23.70	12.01	3.74	11.51	27.16

Output Shaft

Gear Frame	Version	U ³	UY	V	AH	Key	ES	M
26	S1	2.875	3.200	5.75	5.75	3/4 Sq.	5.13	3/4-10 X 1.97
27	S1	3.500	3.882	7.00	7.00	7/8 Sq.	6.25	1-8 X 1.97
28	S1	4.000	4.436	8.00	8.00	1.00 Sq.	7.25	1-8 X 1.97

Output Flange

Gear Frame	Flange Code	AJ	AK	BB	BD	BE	BF
26	5	15.75	13.75	.20	17.72	.79	.71
27	5	15.75	13.78	.20	17.72	.79	.71
28	5	19.69	17.72	.24	21.65	.94	.71

Input Shaft

Gear Frame	Version	RU	U1 ⁴	UY1	V1	Key1
26	S1	6.49	1.375	1.513	2.75	5/16 Sq.
27	S1	5.76	1.875	2.091	3.75	1/2 Sq.
28	S1	7.11	2.375	2.646	4.75	5/8 Sq.

Motor Frame

Gear Frame	182T-184T			213T-215T			254T-256T			284T-286T			324T-326T		
	XH	XL	XW	XH	XL	XW	XH	XL	XW	XH	XL	XW	XH	XL	XW
26	5.56	47.53	12.75	5.56	47.9	12.75	7.63	51.40	17.00	7.63	52.40	17.00	-	-	-
27	6.63	47.93	15.00	6.63	51.43	15.00	7.63	51.81	17.00	7.63	54.31	17.00	9.50	54.31	21.31
28	-	-	-	-	-	-	8.50	58.91	19.06	8.50	59.04	19.06	9.50	60.41	21.31

¹ Dimension "D" will never be exceeded, but may vary from values shown. When exact dimensions are required, shims up to .03" may be necessary.
² All rough casting dimensions may vary by .25" due to casting variations.

³ Output shaft extension tolerances: +.0000"; -.0005" for shafts up to 1.5" diameter "U". Larger diameter "U", +.000"; -.001".
⁴ Input shaft extension tolerances: +.0000"; -.0005" up to 1.5" diameter. Larger diameter "U1", +.000"; -.001".

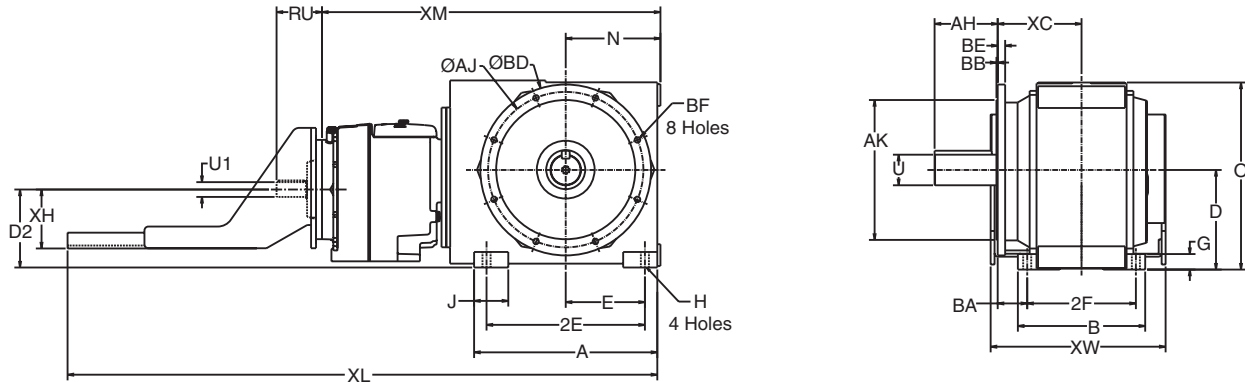

Gear Frame	Version	A	B	D ¹	D2	E	2E	2F	G	H	J	O	N	BA	XC	XM
26A	S1	16.73	11.42	8.86	7.66	6.99	13.98	9.45	1.57	.87	3.54	16.65	8.74	3.54	9.00	30.80
27A	S1	19.29	12.60	9.84	7.89	8.27	16.54	10.63	1.77	.94	3.94	18.50	10.04	3.54	8.55	31.47
28A	S1	23.23	16.14	12.40	10.40	10.04	20.08	13.78	1.97	1.02	4.33	23.70	12.01	3.74	11.51	37.49

Output Shaft

Gear Frame	Version	U ³	UY	V	AH	Key	ES	M
26A	S1	2.875	3.200	5.75	5.75	3/4 Sq.	5.13	3/4-10 X 1.97
27A	S1	3.500	3.882	7.00	7.00	7/8 Sq.	6.25	1-8 X 1.97
28A	S1	4.000	4.436	8.00	8.00	1.00 Sq.	7.25	1-8 X 1.97

Output Flange

Gear Frame	Flange Code	AJ	AK	BB	BD	BE	BF
26A	5	15.75	13.75	.20	17.72	.79	.71
27A	5	15.75	13.78	.20	17.72	.79	.71
28A	5	19.69	17.72	.24	21.65	.94	.71

Input Shaft

Gear Frame	Version	RU	U1 ⁴	UY1	V1	Key1
26A	S1	4.75	1.125	1.236	2.25	1/4 Sq.
27A	S1	4.75	1.125	1.236	2.25	1/4 Sq.
28A	S1	5.03	1.125	1.236	2.25	1/4 Sq.

Motor Frame

Gear Frame	143T-145T			182T-184T			213T-215T		
	XH	XL	XW	XH	XL	XW	XH	XL	XW
26A	4.74	45.62	12.38	4.74	45.62	12.38	-	-	-
27A	4.74	48.62	12.38	4.74	47.71	12.38	-	-	-
28A	5.50	53.22	12.75	5.50	52.82	12.75	5.50	53.22	12.75

¹ Dimension "D" will never be exceeded, but may vary from values shown. When exact dimensions are required, shims up to .03" may be necessary.
² All rough casting dimensions may vary by .25" due to casting variations.

³ Output shaft extension tolerances: +.0000"; -.0005" for shafts up to 1.5" diameter "U". Larger diameter "U", +.000"; -.001".
⁴ Input shaft extension tolerances: +.0000"; -.0005" up to 1.5" diameter. Larger diameter "U1", +.000"; -.001".

3-Stage Finished Bore Hollow Shaft OtN33 - 35

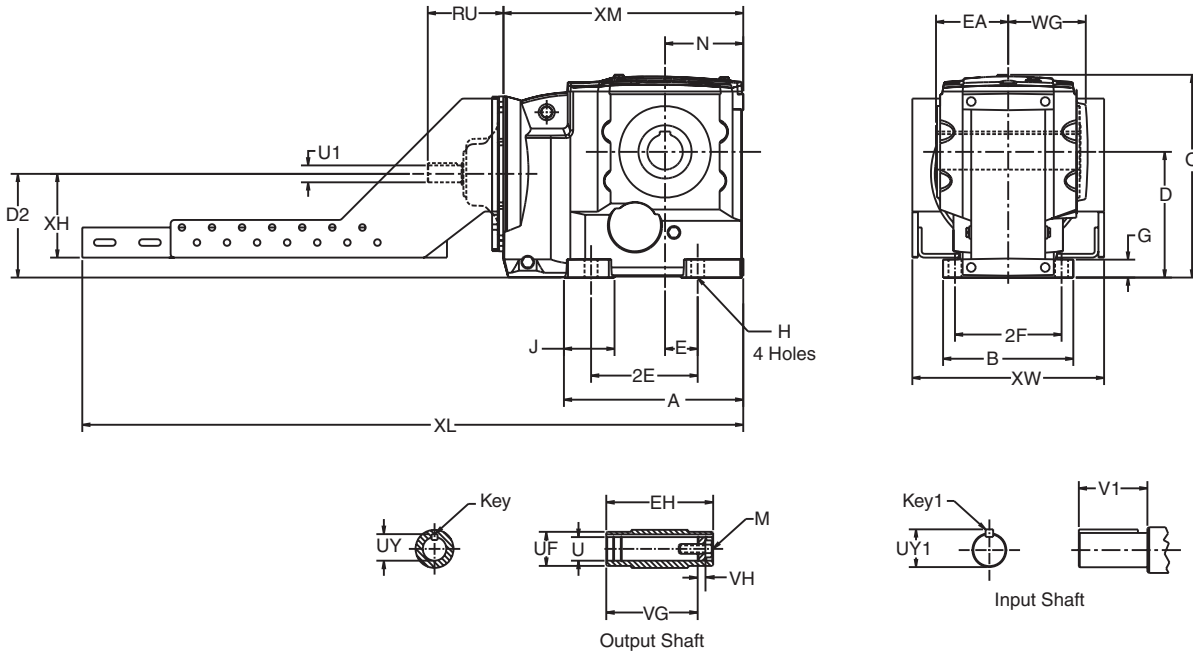

Gear Frame	Version	A	B	D ¹	D2	E	2E	2F	G	H	J	O	N	WG	XM
33	S2	8.50	6.61	5.51	5.24	1.18	4.72	5.51	.85	.55	2.86	9.69	3.54	3.73	11.97
34	S2	10.13	7.87	7.09	5.90	1.57	5.91	6.50	1.07	.71	2.67	12.05	4.49	4.66	13.78
35	S2	11.92	8.66	8.35	6.89	2.17	7.09	7.09	1.18	.87	3.45	13.58	5.20	5.15	15.95

Output Shaft

Gear Frame	Version	EH	U ^{4,7}	UY	EA	UF	VG	VH	Key ⁵	M
33	S2	6.94	1.500	1.674	3.47	2.16	5.96	.55	3/8 X 3/8 X 2 1/4	5/8-11 X 1.75
34	S2	8.97	2.000	2.210	4.49	2.56	7.44	.79	1/2 X 7/16 X 2 5/8	5/8-11 X 1.75
35	S2	9.66	2.375	2.656	4.83	3.54	8.15	.94	5/8 X 5/8 X 3 5/8	3/4-10 X 2.00

Input Shaft

Gear Frame	Version	RU	U ⁶	UY1	V1	Key1
33	S2	3.17	.625	.705	1.25	3/16 Sq.
34	S2	4.75	1.125	1.236	2.25	1/4 Sq.
35	S2	5.03	1.125	1.236	2.25	1/4 Sq.

Motor Frame

Gear Frame	143T-145T			182T-184T			213T-215T		
	XH	XL	XW	XH	XL	XW	XH	XL	XW
33	3.75	30.25	11.38	-	-	-	-	-	-
34	4.74	39.25	12.38	4.74	39.25	12.38	-	-	-
35	5.50	42.61	12.75	5.50	41.61	12.75	5.50	42.01	12.75

¹ Dimension "D" will never be exceeded, but may vary from values shown. When exact dimensions are required, shims up to .03" may be necessary.
² All rough casting dimensions may vary by .25" due to casting variations.
³ Driven shaft entry can be from either side of the gear reducer housing by reversing positioning of the snap rings and washer illustrated.
⁴ Output finished bore tolerance: +.0020", -.0000 for all diameters.

⁵ Output key supplied only on frame 34 "S2" version.
⁶ Input shaft extension tolerances: +.0000"; -.0005" up to 1.5" diameter. Larger diameter "U1", +.000"; -.001".
⁷ Refer to Tapered Bushed designs if driven shaft varies from "U" dimensions offered above.
⁸ For details of the torque arm kit, refer to page B-114.

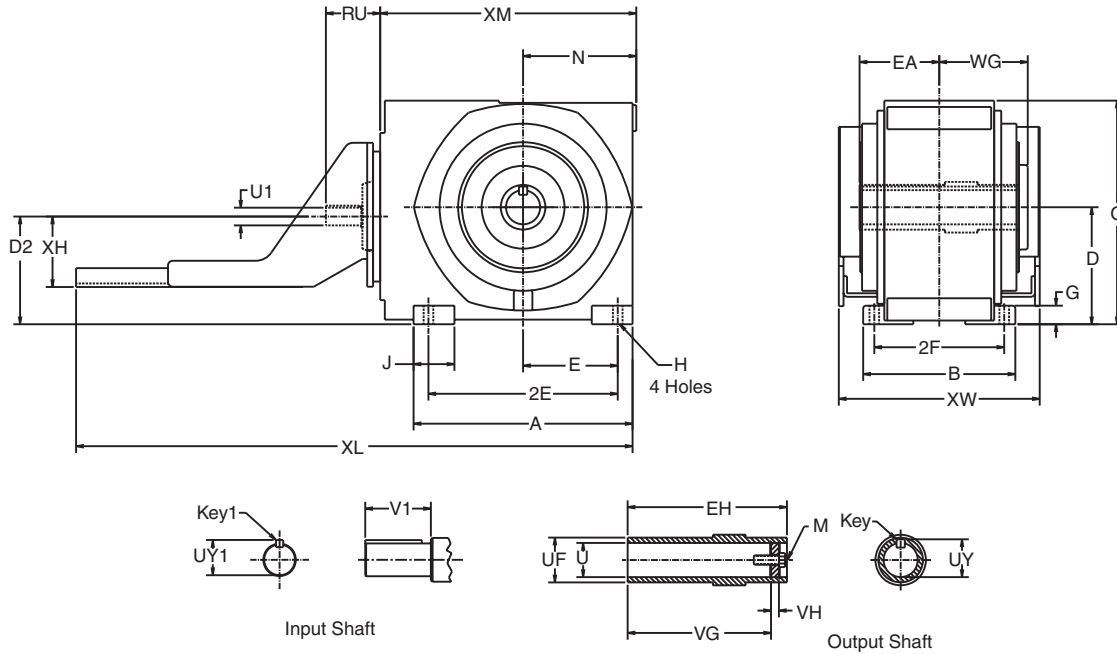

Gear Frame	Version	A	B	D ¹	D2	E	2E	2F	G	H	J	O	N	WG	XM
26	S1	16.73	11.42	8.86	8.43	6.99	13.98	9.45	1.57	.87	3.54	16.65	8.74	6.97	20.15
27	S1	19.29	12.60	9.84	8.66	8.27	16.54	10.63	1.77	.94	3.94	18.50	10.04	7.72	22.24
28	S1	23.23	16.14	12.40	11.42	10.04	20.08	13.78	1.97	1.02	4.33	23.70	12.01	9.49	27.16

Output Shaft

Gear Frame	Version	EA	EH	U ⁴	UF	UY	VG	VH	Key	M
26A	S1	6.10	12.20	2.750	3.35	3.027	10.25	.91	5/8 Sq.	3/4-10
27A	S1	6.70	13.40	3.125	3.75	3.454	11.40	.91	3/4 Sq.	3/4-10
28A	S1	8.45	16.90	3.625	4.35	4.009	14.95	1.02	7/8 Sq.	1-8

Input Shaft

Gear Frame	Version	RU	U1 ⁵	UY1	V1	Key1
26	S1	6.49	1.375	1.513	2.75	5/16 Sq.
27	S1	5.76	1.875	2.091	3.75	1/2 Sq.
28	S1	7.11	2.375	2.646	4.75	5/8 Sq.

Motor Frame

Gear Frame	182T-184T			213T-215T			254T-256T			284T-286T			324T-326T		
	XH	XL	XW	XH	XL	XW	XH	XL	XW	XH	XL	XW	XH	XL	XW
26	5.56	47.53	12.75	5.56	47.9	12.75	7.63	51.40	17.00	7.63	52.40	17.00	-	-	-
27	6.63	47.93	15.00	6.63	51.43	15.00	7.63	51.81	17.00	7.63	54.31	17.00	9.50	54.31	21.31
28	-	-	-	-	-	-	8.50	58.91	19.06	8.50	59.04	19.06	9.50	60.41	21.31

¹ Dimension "D" will never be exceeded, but may vary from values shown. When exact dimensions are required, shims up to .03" may be necessary.
² All rough casting dimensions may vary by .25" due to casting variations.
³ Driven shaft entry can be from either side of the gear reducer housing by reversing positioning of the snap rings and washer illustrated.

⁴ Output finished bore tolerance: +.0020", -.0000 for all diameters.
⁵ Input shaft extension tolerances: +.0000"; -.0005" up to 1.5" diameter. Larger diameter "U1", +.000"; -.001".
⁶ For details of the torque arm kit, refer to page B-115.

Combined Finished Bore Hollow Shaft OtN26 - 28

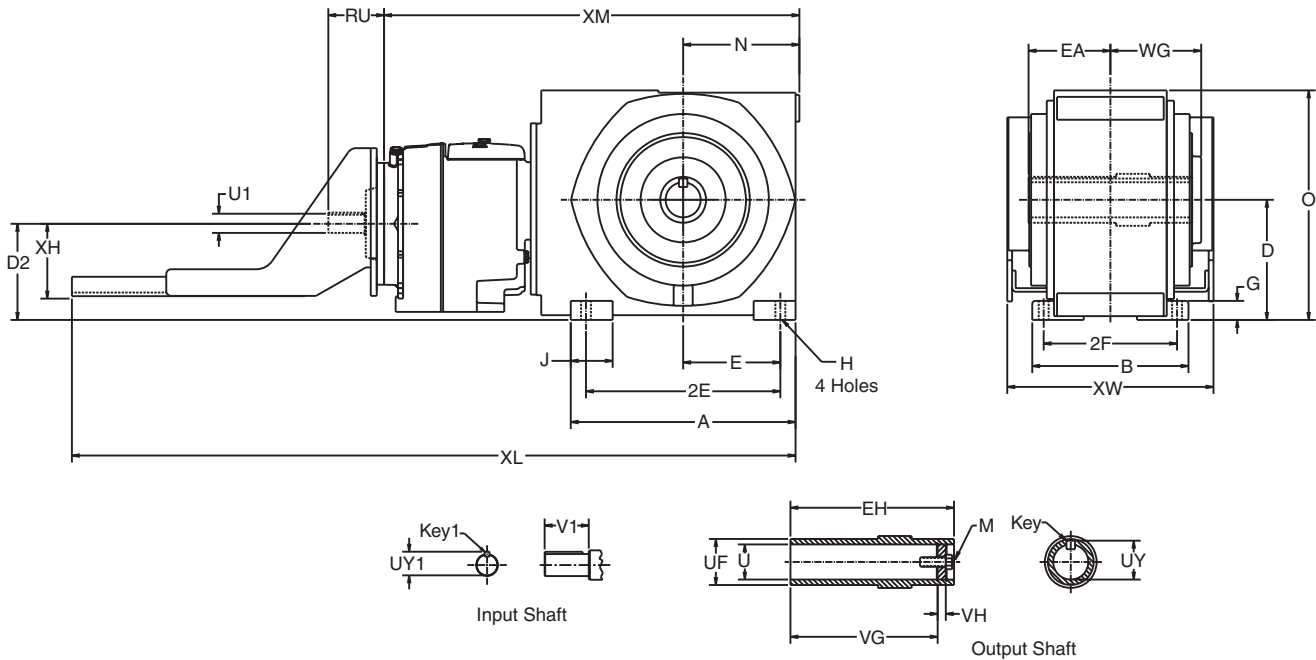

Gear Frame	Version	A	B	D ¹	D2	E	2E	2F	G	H	J	O	N	WG	XM
26A	S1	16.73	11.42	8.86	7.66	6.99	13.98	9.45	1.57	.87	3.54	16.65	8.74	6.97	30.80
27A	S1	19.29	12.60	9.84	7.89	8.27	16.54	10.63	1.77	.94	3.94	18.50	10.04	7.72	31.47
28A	S1	23.23	16.14	12.40	10.40	10.04	20.08	13.78	1.97	1.02	4.33	23.70	12.01	9.49	37.49

Output Shaft

Gear Frame	Version	EA	EH	U ⁴	UF	UY	VG	VH	Key	M
26A	S1	6.10	12.20	2.750	3.35	3.027	10.25	.91	5/8 Sq.	3/4-10
27A	S1	6.70	13.40	3.125	3.75	3.454	11.40	.91	3/4 Sq.	3/4-10
28A	S1	8.45	16.90	3.625	4.35	4.009	14.95	1.02	7/8 Sq.	1-8

Input Shaft

Gear Frame	Version	RU	U1 ⁵	UY1	V1	Key1
26A	S1	4.75	1.125	1.236	2.25	1/4 Sq.
27A	S1	4.75	1.125	1.236	2.25	1/4 Sq.
28A	S1	5.03	1.125	1.236	2.25	1/4 Sq.

Motor Frame

Gear Frame	143T-145T			182T-184T			213T-215T		
	XH	XL	XW	XH	XL	XW	XH	XL	XW
26A	4.74	45.62	12.38	4.74	45.62	12.38	-	-	-
27A	4.74	48.62	12.38	4.74	47.71	12.38	-	-	-
28A	5.50	53.22	12.75	5.50	52.82	12.75	5.50	53.22	12.75

¹ Dimension "D" will never be exceeded, but may vary from values shown. When exact dimensions are required, shims up to .03" may be necessary.

² All rough casting dimensions may vary by .25" due to casting variations.

³ Driven shaft entry can be from either side of the gear reducer housing by reversing positioning of the snap rings and washer illustrated.

⁴ Output finished bore tolerance: +.0020", -.0000 for all diameters.

⁵ Input shaft extension tolerances: +.0000"; -.0005" up to 1.5" diameter. Larger diameter "U1", +.000"; -.001".

⁶ For details of the torque arm kit, refer to page B-115.

3-Stage Finished Bore Hollow Shaft Face Mount OtN33 - 35

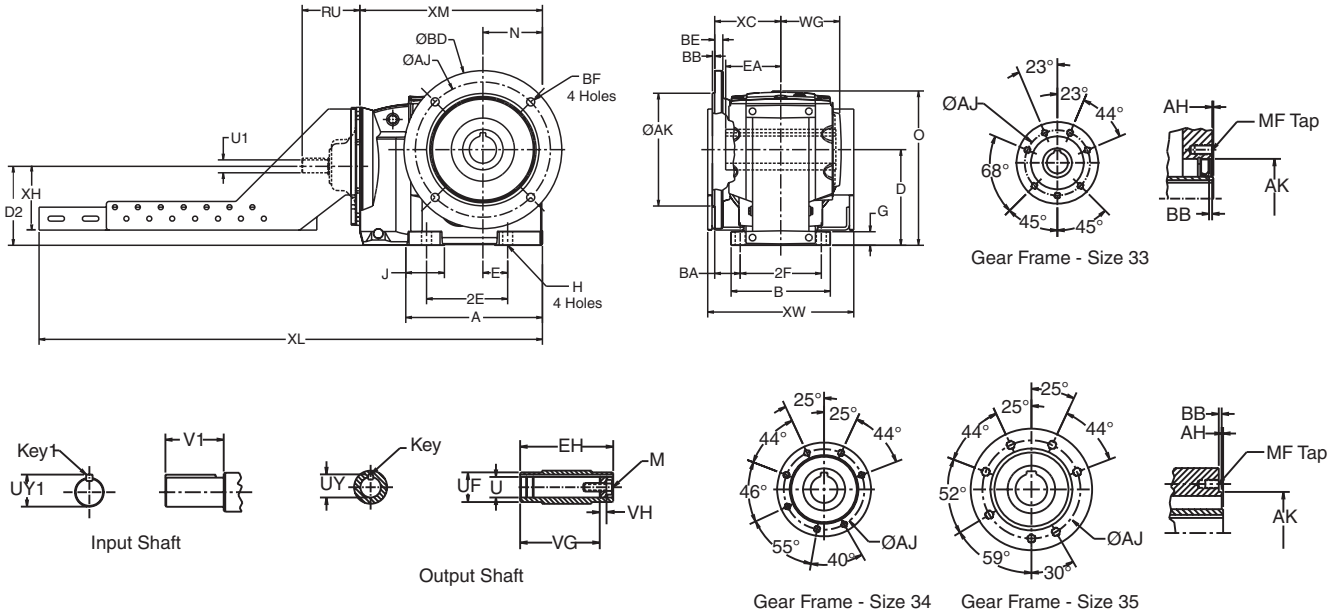

OtN Series

Gear Frame	Version	A	B	D ¹	D2	E	2E	2F	G	H	J	O	N	WG	XM
33	S2	8.50	6.61	5.51	5.24	1.18	4.72	5.51	.85	.55	2.86	9.69	3.54	3.63	11.97
34	S2	10.13	7.87	7.09	5.90	1.57	5.91	6.50	1.07	.71	2.67	12.05	4.49	4.66	13.78
35	S2	11.92	8.66	8.35	6.89	2.17	7.09	7.09	1.18	.87	3.45	13.58	5.20	5.15	15.95

Output Shaft

Gear Frame	Version	EA	EH	U ⁵	UF	UY	VG	VH	Key ⁴	M
33	S2	3.47	6.94	1.500	2.16	1.674	5.96	.55	3/8 X 3/8 X 2 1/4	5/8-11 X 1.75
34	S2	4.49	8.97	2.000	2.56	2.210	7.44	.79	1/2 X 7/16 X 2 5/8	5/8-11 X 1.75
35	S2	4.83	9.66	2.375	3.54	2.656	8.15	.94	5/8 X 5/8 X 3 5/8	3/4-10 X 2.00

Output Face

Gear Frame	Version	AH	AJ	AK	BB	MF
33	S2	.12	4.84	3.94	.16	M12 X .87
34	S2	.14	5.98	5.12	.28	M10 X .87
35	S2	.13	7.48	6.10	.28	M12 X .87

Input Shaft

Gear Frame	Version	RU	U1 ⁶	UY1	V1	KEY ¹
33	S2	3.17	.625	.705	1.25	3/16 Sq.
34	S2	4.75	1.125	1.236	2.25	1/4 Sq.
35	S2	5.03	1.125	1.236	2.25	1/4 Sq.

Motor Frame

Gear Frame	143T-145T			182T-184T			213T-215T		
	XH	XL	XW	XH	XL	XW	XH	XL	XW
33	3.75	30.25	11.38	-	-	-	-	-	-
34	4.74	39.25	12.38	4.74	39.25	12.38	-	-	-
35	5.50	42.61	12.75	5.50	41.61	12.75	5.50	42.01	12.75

¹ Dimension "D" will never be exceeded, but may vary from values shown. When exact dimensions are required, shims up to .03" may be necessary.
² All rough casting dimensions may vary by .25" due to casting variations.
³ Driven shaft entry can be from either side of the gear reducer housing by reversing positioning of the snap rings and washer illustrated.

⁴ Output key supplied only on frame 34 "S2" version.
⁵ Output finished bore tolerance: +.0020", -.0000 for all diameters.
⁶ Input shaft extension tolerances: +.0000", -.0005" up to 1.5" diameter. Larger diameter "U1", +.000"; -.001".

3-Stage Finished Bore Hollow Shaft Face Mount OtN26 - 28

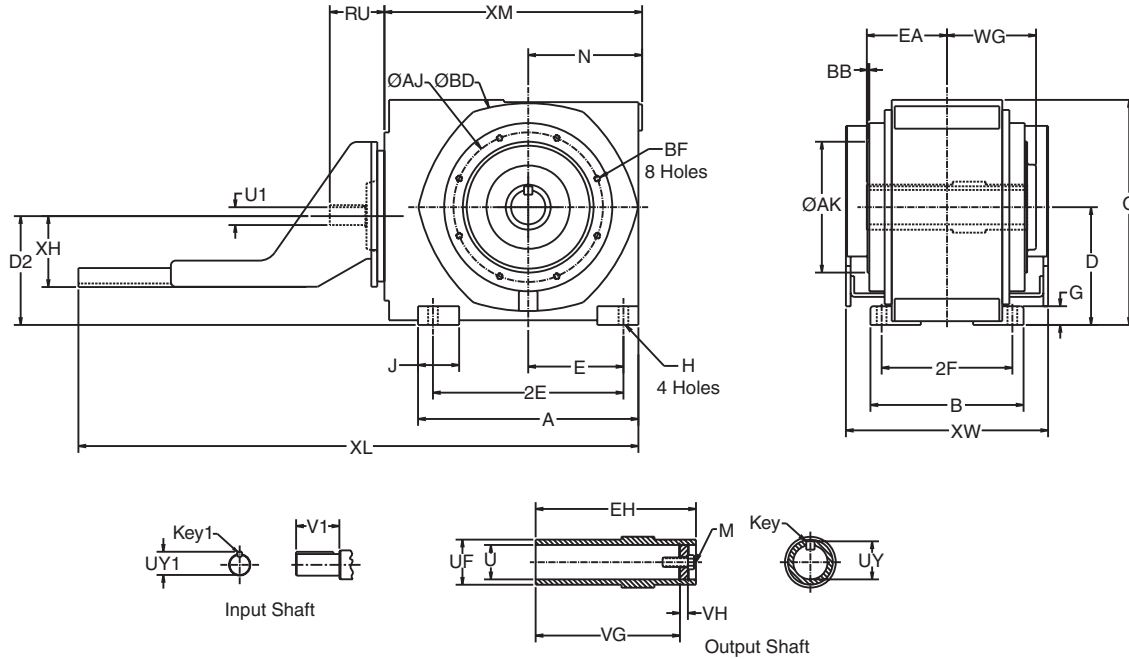

Gear Frame	Version	A	B	D ¹	D2	E	2E	2F	G	H	J	O	N	WG	XM
26	S1	16.73	11.42	8.86	8.43	6.99	13.98	9.45	1.57	.87	3.54	16.65	8.74	6.97	20.15
27	S1	19.29	12.60	9.84	8.66	8.27	16.54	10.63	1.77	.94	3.94	18.50	10.04	7.72	22.24
28	S1	23.23	16.14	12.40	11.42	10.04	20.08	13.78	1.97	1.02	4.33	23.70	12.01	9.49	27.16

Output Shaft

Gear Frame	Version	EA	EH	U ⁴	UF	UY	VG	VH	Key	M
26	S1	6.10	12.20	2.750	3.35	3.027	10.25	.91	5/8 Sq.	3/4-10 X 1.25
27	S1	6.70	13.40	3.125	3.75	3.454	11.40	.91	3/4 Sq.	3/4-10 X 1.25
28	S1	8.45	16.90	3.625	4.35	4.009	14.95	1.02	7/8 Sq.	1-8 X 1.25

Output Face

Gear Frame	Version	AJ	AK	BB	BD	BF
26	S1	11.81	9.84	.20	13.78	M16 X 22
27	S1	13.78	11.81	.20	15.75	M16 X 22
28	S1	15.75	13.78	.20	17.72	M16 X 22

Input Shaft

Gear Frame	Version	RU	U1 ⁵	UY1	V1	Key1
26	S1	6.49	1.375	1.513	2.75	5/16 Sq.
27	S1	5.76	1.875	2.091	3.75	1/2 Sq.
28	S1	7.11	2.375	2.646	4.75	5/8 Sq.

Motor Frame

Gear Frame	182T-184T			213T-215T			254T-256T			284T-286T			324T-326T		
	XH	XL	XW	XH	XL	XW	XH	XL	XW	XH	XL	XW	XH	XL	XW
26	5.56	47.53	12.75	5.56	47.9	12.75	7.63	51.40	17.00	7.63	52.40	17.00	-	-	-
27	6.63	47.93	15.00	6.63	51.43	15.00	7.63	51.81	17.00	7.63	54.31	17.00	9.50	54.31	21.31
28	-	-	-	-	-	-	8.50	58.91	19.06	8.50	59.04	19.06	9.50	60.41	21.31

¹ Dimension "D" will never be exceeded, but may vary from values shown. When exact dimensions are required, shims up to .03" may be necessary.
² All rough casting dimensions may vary by .25" due to casting variations.
³ Driven shaft entry can be from either side of the gear reducer housing by reversing positioning of the snap rings and washer illustrated.

⁴ Output finished bore tolerance: +.0020", -.0000 for all diameters.
⁵ Input shaft extension tolerances: +.0000"; -.0005" up to 1.5" diameter. Larger diameter "U1", +.000"; -.001".

Combined Finished Bore Hollow Shaft Face Mount OtN26 - 28

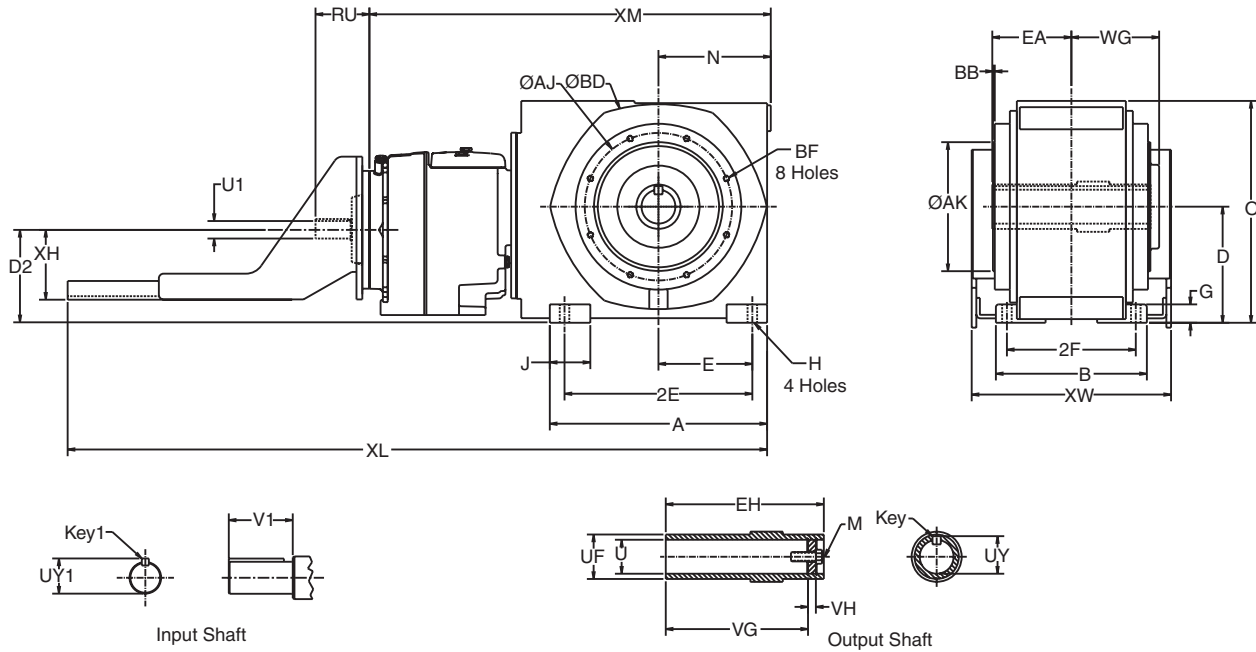

OtN Series

Gear Frame	Version	A	B	D ¹	D2	E	2E	2F	G	H	J	O	N	WG	XM
26A	S1	16.73	11.42	8.86	7.66	6.99	13.98	9.45	1.57	.87	3.54	16.65	8.74	6.97	30.80
27A	S1	19.29	12.60	9.84	7.89	8.27	16.54	10.63	1.77	.94	3.94	18.50	10.04	7.72	31.47
28A	S1	23.23	16.14	12.40	10.40	10.04	20.08	13.78	1.97	1.02	4.33	23.70	12.01	9.49	37.49

Output Shaft

Gear Frame	Version	EA	EH	U ⁴	UF	UY	VG	VH	Key	M
26A	S1	6.10	12.20	2.750	3.35	3.027	10.25	.91	5/8 Sq.	3/4-10
27A	S1	6.70	13.40	3.125	3.75	3.454	11.40	.91	3/4 Sq.	3/4-10
28A	S1	8.45	16.90	3.625	4.35	4.009	14.95	1.02	7/8 Sq.	1-8

Output Face

Gear Frame	Version	AJ	AK	BB	BD	BF
26A	S1	11.81	9.84	.20	13.78	M16 X 22
27A	S1	13.78	11.81	.20	15.75	M16 X 22
28A	S1	15.75	13.78	.20	17.72	M16 X 22

Input Shaft

Gear Frame	Version	RU	U1 ⁵	UY1	V1	Key1
26A	S1	4.75	1.125	1.236	2.25	1/4 Sq.
27A	S1	4.75	1.125	1.236	2.25	1/4 Sq.
28A	S1	5.03	1.125	1.236	2.25	1/4 Sq.

Motor Frame

Gear Frame	143T-145T			182T-184T			213T-215T		
	XH	XL	XW	XH	XL	XW	XH	XL	XW
26A	4.74	45.62	12.38	4.74	45.62	12.38	-	-	-
27A	4.74	48.62	12.38	4.74	47.71	12.38	-	-	-
28A	5.50	53.22	12.75	5.50	52.82	12.75	5.50	53.22	12.75

¹ Dimension "D" will never be exceeded, but may vary from values shown. When exact dimensions are required, shims up to .03" may be necessary.
² All rough casting dimensions may vary by .25" due to casting variations.
³ Driven shaft entry can be from either side of the gear reducer housing by reversing positioning of the snap rings and washer illustrated.

⁴ Output finished bore tolerance: +.0020", -.0000 for all diameters.
⁵ Input shaft extension tolerances: +.0000"; -.0005" up to 1.5" diameter. Larger diameter "U1", +.000"; -.001".

3-Stage Finished Bore Hollow Shaft Flange Mount OtN33 - 35

OtN Series

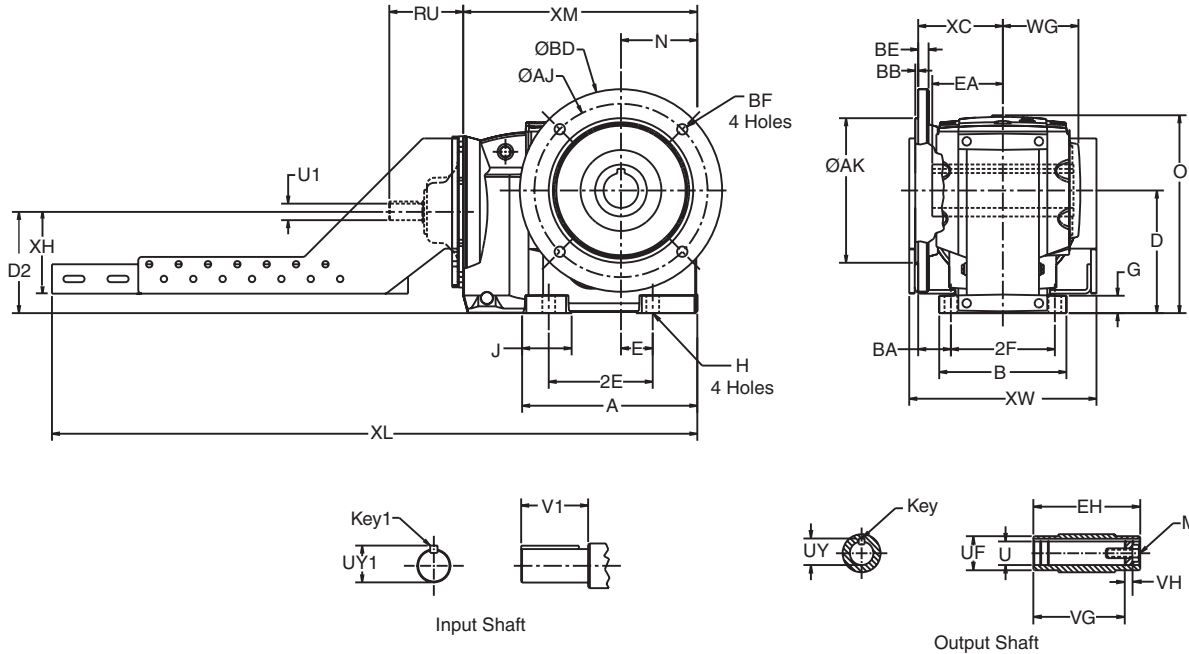

Gear Frame	Version	A	B	D ¹	D2	E	2E	2F	G	H	J	O	N	BA	WG	XC	XM
33	S2	8.50	6.61	5.51	5.24	1.18	4.72	5.51	.85	.55	2.86	9.69	3.54	2.08	3.73	4.84	11.97
34	S2	10.13	7.87	7.09	5.90	1.57	5.91	6.50	1.07	.71	2.67	12.05	4.49	1.93	4.66	5.18	13.78
35	S2	11.92	8.66	8.35	6.89	2.17	7.09	7.09	1.18	.87	3.45	13.58	5.20	2.22	5.15	5.77	15.95

Output Shaft

Gear Frame	Version	EA	EH	U ⁵	UF	UY	VG	VH	Key ⁴	M
33	S2	3.47	6.94	1.500	2.16	1.674	5.96	.55	3/8 X 3/8 X 2 1/4	5/8-11 X 1.75
34	S2	4.49	8.97	2.000	2.56	2.210	7.44	.79	1/2 X 7/16 X 2 5/8	5/8-11 X 1.75
35	S2	4.83	9.66	2.375	3.54	2.656	8.15	.94	5/8 X 5/8 X 3 5/8	3/4-10 X 2.00

Output Flange

Gear Frame	Flange Code	AK	AJ	BB	BD	BE	BF
33	5	7.087	8.46	.16	9.84	.47	.55
	6	9.055	10.43	.16	11.81	.47	.55
34	5	9.055	10.43	.16	11.81	.59	.55
	6	9.842	11.80	.16	13.77	.59	.71
35	5	9.842	11.80	.20	13.77	.71	.71
	6	11.810	13.77	.20	15.75	.71	.71

Input Shaft

Gear Frame	Version	RU	U1 ⁶	UY1	V1	Key1
33	S2	3.17	.625	.705	1.25	3/16 Sq.
34	S2	4.75	1.125	1.236	2.25	1/4 Sq.
35	S2	5.03	1.125	1.236	2.25	1/4 Sq.

Motor Frame

Gear Frame	143T-145T			182T-184T			213T-215T		
	XH	XL	XW	XH	XL	XW	XH	XL	XW
33	3.75	30.25	11.38	-	-	-	-	-	-
34	4.74	39.25	12.38	4.74	39.25	12.38	-	-	-
35	5.50	42.61	12.75	5.50	41.61	12.75	5.50	42.01	12.75

¹ Dimension "D" will never be exceeded, but may vary from values shown. When exact dimensions are required, shims up to .03" may be necessary.
² All rough casting dimensions may vary by .25" due to casting variations.
³ Driven shaft entry can be from either side of the gear reducer housing by reversing positioning of the snap rings and washer illustrated.

⁴ Output key supplied only on frame 34 "S2" version.
⁵ Output finished bore tolerance: +.0020", -.0000" for all diameters.
⁶ Input shaft extension tolerances: +.0000"; -.0005" up to 1.5" diameter. Larger diameter "U1", +.000"; -.001".

3-Stage Finished Bore Hollow Shaft Flange Mount OtN26 - 28

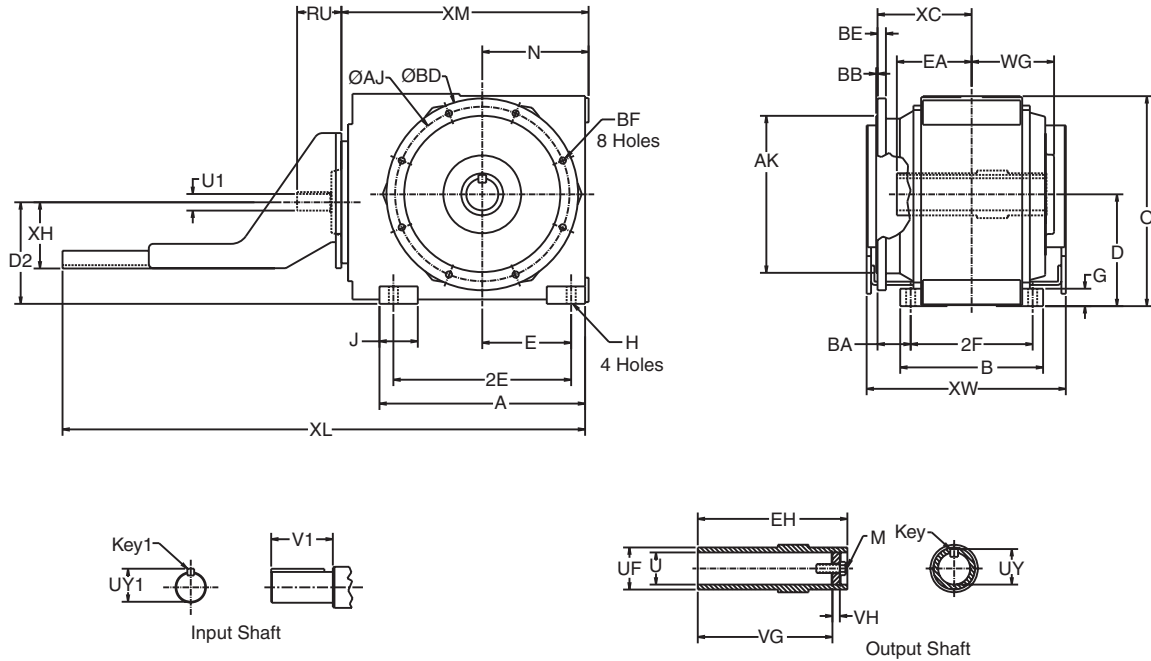

OtN Series

Gear Frame	Version	A	B	D ¹	D2	E	2E	2F	G	H	J	O	N	BA	WG	XC	XM
26	S1	16.73	11.42	8.86	8.43	6.99	13.98	9.45	1.57	.87	3.54	16.65	8.74	3.54	6.97	9.00	20.15
27	S1	19.29	12.60	9.84	8.66	8.27	16.54	10.63	1.77	.94	3.94	18.50	10.04	3.54	7.72	8.55	22.24
28	S1	23.23	16.14	12.40	11.42	10.04	20.08	13.78	1.97	1.02	4.33	23.70	12.01	3.74	9.49	11.51	27.16

Output Shaft

Gear Frame	Version	EA	EH	U ⁴	UF	UY	VG	VH	Key	M
26	S1	6.10	12.20	2.750	3.35	3.027	10.25	.91	5/8 Sq.	3/4-10
27	S1	6.70	13.40	3.125	3.75	3.454	11.40	.91	3/4 Sq.	3/4-10
28	S1	8.45	16.90	3.625	4.35	4.009	14.95	1.02	7/8 Sq.	1-8

Output Flange

Gear Frame	Flange Code	AJ	AK	BB	BD	BE	BF
26	5	15.75	13.75	.20	17.72	.79	.71
27	5	15.75	13.78	.20	17.72	.79	.71
28	5	19.69	17.72	.24	21.65	.94	.71

Input Shaft

Gear Frame	Version	RU	U1 ⁵	UY1	V1	Key1
26	S1	6.49	1.375	1.513	2.75	5/16 Sq.
27	S1	5.76	1.875	2.091	3.75	1/2 Sq.
28	S1	7.11	2.375	2.646	4.75	5/8 Sq.

Motor Frame

Gear Frame	182T-184T			213T-215T			254T-256T			284T-286T			324T-326T		
	XH	XL	XW	XH	XL	XW	XH	XL	XW	XH	XL	XW	XH	XL	XW
26	5.56	47.53	12.75	5.56	47.9	12.75	7.63	51.40	17.00	7.63	52.40	17.00	-	-	-
27	6.63	47.93	15.00	6.63	51.43	15.00	7.63	51.81	17.00	7.63	54.31	17.00	9.50	54.31	21.31
28	-	-	-	-	-	-	8.50	58.91	19.06	8.50	59.04	19.06	9.50	60.41	21.31

¹ Dimension "D" will never be exceeded, but may vary from values shown. When exact dimensions are required, shims up to .03" may be necessary.
² All rough casting dimensions may vary by .25" due to casting variations.
³ Driven shaft entry can be from either side of the gear reducer housing by reversing positioning of the snap rings and washer illustrated.

⁴ Output finished bore tolerance: +.0020", -.0000 for all diameters.
⁵ Input shaft extension tolerances: +.0000"; -.0005" up to 1.5" diameter. Larger diameter "U1", +.000"; -.001".

Combined Finished Bore Hollow Shaft Flange Mount OtN26 - 28

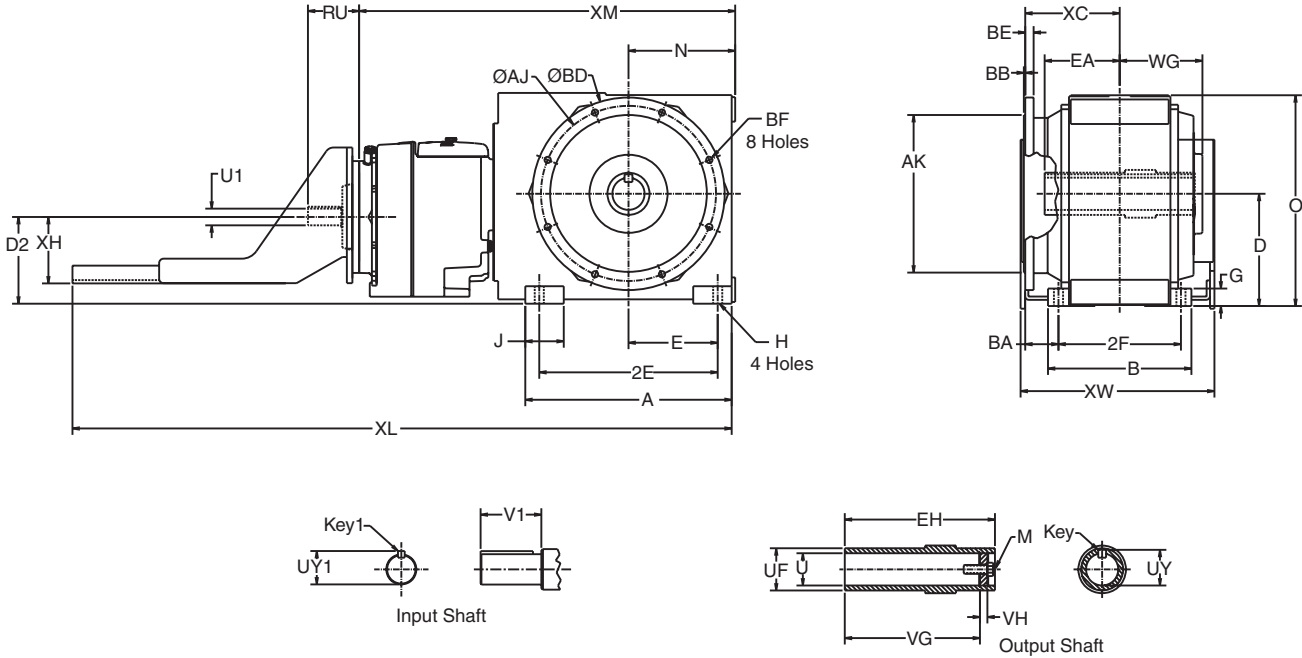

Gear Frame	Version	A	B	D'	D2	E	2E	2F	G	H	J	O	N	BA	WG	XC	XM
26A	S1	16.73	11.42	8.86	7.66	6.99	13.98	9.45	1.57	.87	3.54	16.65	8.74	3.54	6.97	9.00	30.80
27A	S1	19.29	12.60	9.84	7.89	8.27	16.54	10.63	1.77	.94	3.94	18.50	10.04	3.54	7.72	8.55	31.47
28A	S1	23.23	16.14	12.40	10.40	10.04	20.08	13.78	1.97	1.02	4.33	23.70	12.01	3.74	9.49	11.51	37.49

Output Shaft

Gear Frame	Version	EA	EH	U ⁵	UF	UY	VG	VH	Key ⁴	M
26A	S1	6.10	12.20	2.750	3.35	3.027	10.25	.91	5/8 Sq.	3/4-10
27A	S1	6.70	13.40	3.125	3.75	3.454	11.40	.91	3/4 Sq.	3/4-10
28A	S1	8.45	16.90	3.625	4.35	4.009	14.95	1.02	7/8 Sq.	1-8

Output Flange

Gear Frame	Flange Code	AJ	AK	BB	BD	BE	BF
26A	5	15.75	13.75	.20	17.72	.79	.71
27A	5	15.75	13.78	.20	17.72	.79	.71
28A	5	19.69	17.72	.24	21.65	.94	.71

Input Shaft

Gear Frame	Version	RU	U1 ⁵	UY1	V1	Key1
26A	S1	4.75	1.125	1.236	2.25	1/4 Sq.
27A	S1	4.75	1.125	1.236	2.25	1/4 Sq.
28A	S1	5.03	1.125	1.236	2.25	1/4 Sq.

Motor Frame

Gear Frame	143T-145T			182T-184T			213T-215T		
	XH	XL	XW	XH	XL	XW	XH	XL	XW
26A	4.74	45.62	12.38	4.74	45.62	12.38	-	-	-
27A	4.74	48.62	12.38	4.74	47.71	12.38	-	-	-
28A	5.50	53.22	12.75	5.50	52.82	12.75	5.50	53.22	12.75

¹ Dimension "D" will never be exceeded, but may vary from values shown. When exact dimensions are required, shims up to .03" may be necessary.
² All rough casting dimensions may vary by .25" due to casting variations.
³ Driven shaft entry can be from either side of the gear reducer housing by reversing positioning of the snap rings and washer illustrated.

⁴ Output finished bore tolerance: +.0020", -.0000 for all diameters.
⁵ Input shaft extension tolerances: +.0000"; -.0005" up to 1.5" diameter. Larger diameter "U1", +.000"; -.001".

3-Stage Taper Bushed Shaft Mount OtN33 - 35

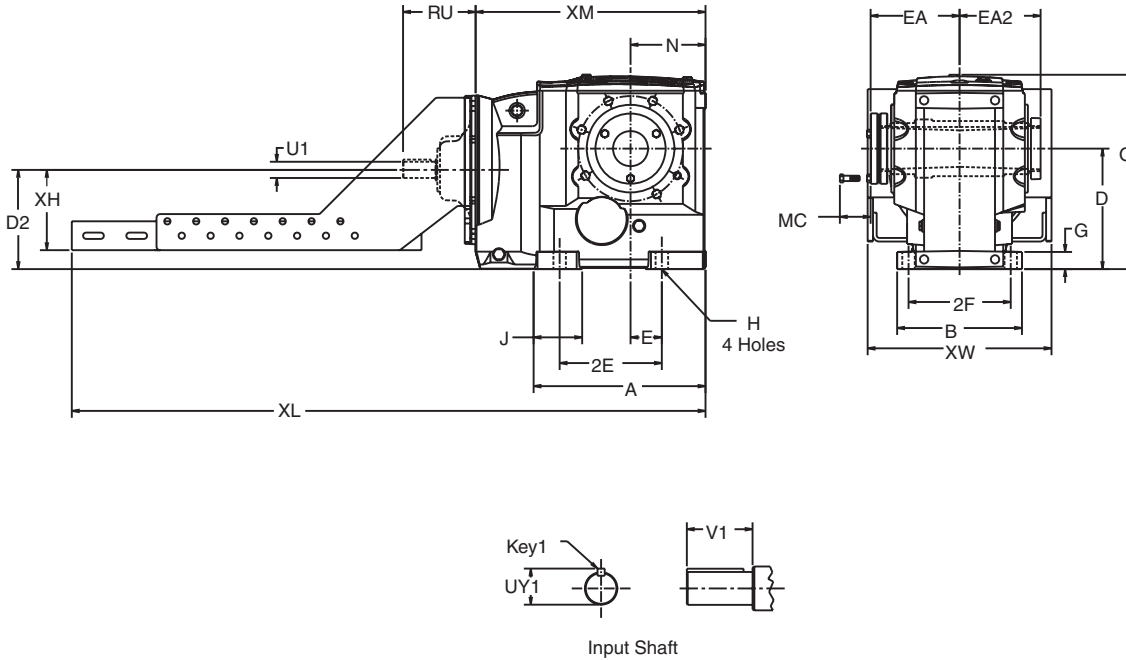

OtN Series

Gear Frame	Version	A	B	D ¹	D2	E	2E	2F	G	H	J	O	N	XM
33	S2	8.50	6.61	5.51	5.24	1.18	4.72	5.51	.85	.55	2.86	9.69	3.54	11.97
34	S2	10.13	7.87	7.09	5.90	1.57	5.91	6.50	1.07	.71	2.67	12.05	4.49	13.78
35	S2	11.92	8.66	8.35	6.89	2.17	7.09	7.09	1.18	.87	3.45	13.58	5.20	15.95

Output Shaft

Gear Frame	Version	EA	EA2	MC ⁵	Bushing Bores ⁴	
					Min.	Max.
33	S2	4.82	4.23	1.75	3/4	1 7/16
34	S2	5.84	5.27	1.88	15/16	1 15/16
35	S2	6.17	5.620	1.88	1 3/8	2 7/16

Input Shaft

Gear Frame	Version	RU	U1 ³	UY1	V1	Key1
33	S2	3.17	.625	.705	1.25	3/16 Sq.
34	S2	4.75	1.125	1.236	2.25	1/4 Sq.
35	S2	5.03	1.125	1.236	2.25	1/4 Sq.

Motor Frame

Gear Frame	143T-145T			182T-184T			213T-215T		
	XH	XL	XW	XH	XL	XW	XH	XL	XW
33	3.75	30.25	11.38	-	-	-	-	-	-
34	4.74	39.25	12.38	4.74	39.25	12.38	-	-	-
35	5.50	42.61	12.75	5.50	41.61	12.75	5.50	42.01	12.75

¹ Dimension "D" will never be exceeded, but may vary from values shown. When exact dimensions are required, shims up to .03" may be necessary.
² All rough casting dimensions may vary by .25" due to casting variations.
³ Input shaft extension tolerances: +.0000"; -.0005" for shafts up to 1.5" diameter. Larger diameter "U1", +.000"; -.001".
⁴ Refer to page B-116 by gear frame for listing of all inch and metric bushing bore sizes available.

⁵ The MC dimension shows spacing required to install or remove the bushing from the reducer.
⁶ Bushing and dust cap can be installed opposite of how they are shown above.
⁷ Driven shaft entry can be from either side of the gear reducer housing. Refer to installation manual for requirements.
⁸ For details of the torque arm kit, refer to pages B-22 - B-23.

3-Stage Output Shafted Foot Mount OtN33 - 35

OtN Series

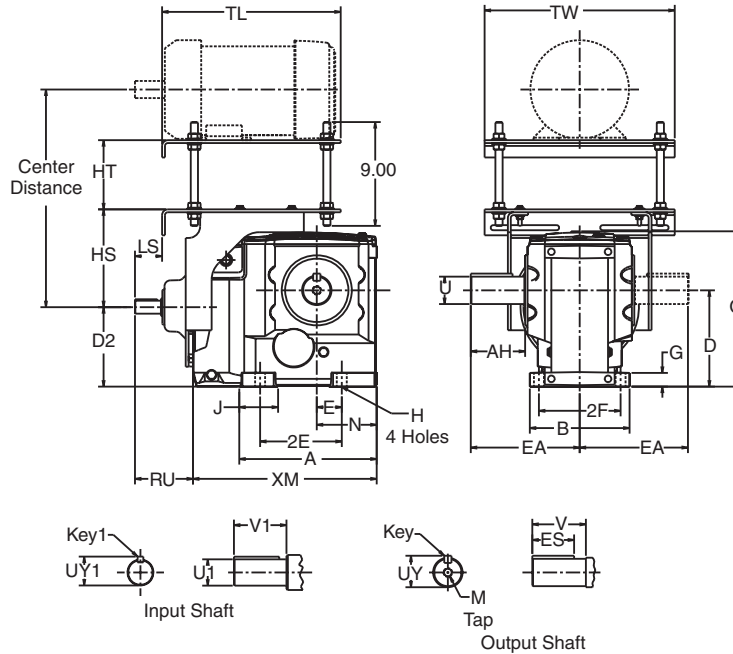

Gear Frame	Version	A	B	D ¹	D ₂	E	2E	2F	G	H	J	O	N	XM	LS	HS	HT	TL	TW
33	S2	8.50	6.61	5.51	5.24	1.18	4.72	5.51	.85	.55	2.86	9.69	3.54	11.97	1.29	7.14	6.00	15.50	16.50
	S1	8.08	8.58	4.92	5.20	3.35	6.69	6.10	.79	.55	2.27	10.43	3.54	11.97					
34	S2	10.13	7.87	7.09	5.90	1.57	5.91	6.50	1.07	.71	2.67	12.05	4.49	13.78	2.31	7.17	6.00	15.50	16.50
	S1	10.69	9.60	6.30	7.49	4.53	9.06	7.68	1.18	.71	3.19	13.39	4.49	13.78					
35	S2	11.92	8.66	8.35	6.89	2.17	7.09	7.09	1.18	.87	3.37	13.58	5.20	15.95	2.35	8.48	6.00	15.50	16.50
	S1	13.07	10.98	7.87	9.33	5.51	11.02	9.06	1.40	.87	4.05	16.22	5.20	15.95					

Output Shaft

Gear Frame	Version	U ³	UY	V	AH	EA	Key	ES	M
33	S2	1.625	1.783	3.25	3.39	6.73	3/8 Sq.	2.78	5/8-11 X 1.38
	S1	1.500	1.657	3.18	3.19	7.12	3/8 Sq.	2.78	5/8-11 X 1.38
34	S2	2.000	2.210	3.63	3.76	8.11	1/2 Sq.	3.06	3/4-10 X 1.61
	S1	1.750	1.909	3.56	3.66	8.46	3/8 Sq.	3.56	3/4-10 X 1.61
35	S2	2.375	2.638	4.61	4.74	9.45	5/8 Sq.	3.81	3/4-10 X 1.61
	S1	2.375	2.638	5.73	5.27	10.57	5/8 Sq.	4.81	3/4-10 X 1.61

Input Shaft

Gear Frame	Version	RU	U ¹ ⁴	UY ¹	V ¹	Key ¹
33	S1,S2	3.17	.625	.70	1.25	3/16 Sq.
34	S1,S2	4.75	1.125	1.24	2.25	1/4 Sq.
35	S1,S2	5.03	1.125	1.24	2.25	1/4 Sq.

Motor Frame	33		34		35	
	Center Distance		Center Distance		Center Distance	
	Min.	Max.	Min.	Max.	Min.	Max.
56	12.28	18.25	12.31	18.28	-	-
143T/145T	12.28	18.25	12.31	18.28	13.87	19.34
182T/184T	13.28	19.25	13.31	19.28	14.87	20.34
213T/215T	-	-	14.06	20.03	15.62	21.09
254T/256T	-	-	-	-	16.62	22.09

¹ Dimension "D" will never be exceeded, but may vary from values shown. When exact dimensions are required, shims up to .03" may be necessary.
² All rough casting dimensions may vary by .25" due to casting variations.

³ Output shaft extension tolerances: +.0000"; -.0005" for shafts up to 1.5" diameter "U". Larger diameter "U", +.000"; -.001".
⁴ Input shaft extension tolerances: +.0000"; -.0005" up to 1.5" diameter. Larger diameter "U¹", +.000"; -.001".

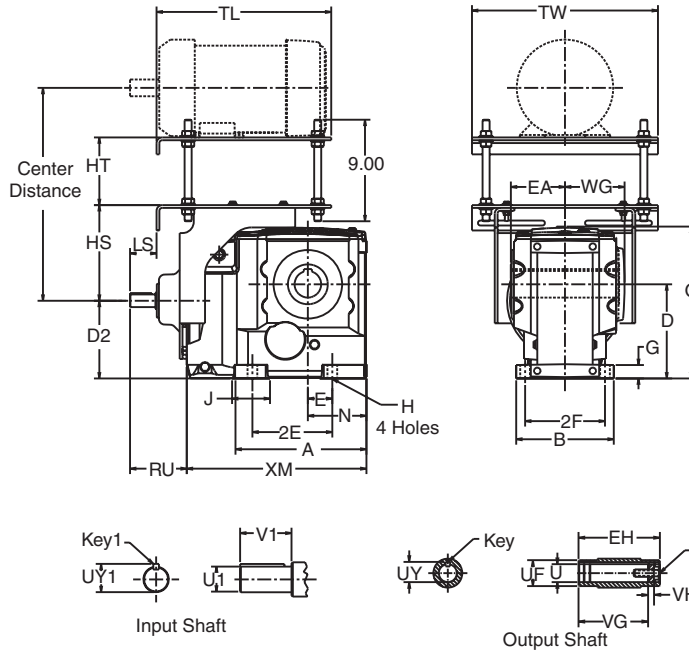

Gear Frame	Version	A	B	D ¹	D2	E	2E	2F	G	H	J	O	N	WG	XM	LS	HS	HT	TL	TW
33	S2	8.50	6.61	5.51	5.24	1.18	4.72	5.51	.85	.55	2.86	9.69	3.54	3.73	11.97	1.29	7.14	6.00	15.50	16.50
34	S2	10.13	7.87	7.09	5.90	1.57	5.91	6.50	1.07	.71	2.67	12.05	4.49	4.66	13.78	2.31	7.17	6.00	15.50	16.50
35	S2	11.92	8.66	8.35	6.89	2.17	7.09	7.09	1.18	.87	3.45	13.58	5.20	5.15	15.95	2.35	8.48	6.00	15.50	16.50

Output Shaft

Gear Frame	Version	EA	EH	U ^{4,7}	UF	UY	VG	VH	Key ⁵	M
33	S2	3.47	6.94	1.500	2.16	1.674	5.96	.55	3/8 X 3/8 X 2 1/4	5/8-11 X 1.75
34	S2	4.49	8.97	2.000	2.56	2.210	7.44	.79	1/2 X 7/16 X 2 5/8	5/8-11 X 1.75
35	S2	4.83	9.66	2.375	3.54	2.656	8.15	.94	5/8 X 5/8 X 3 5/8	3/4-10 X 2.00

Input Shaft

Gear Frame	Version	RU	U1 ⁶	UY1	V1	Key1
33	S2	3.17	.625	.70	1.25	3/16 Sq.
34	S2	4.75	1.125	1.24	2.25	1/4 Sq.
35	S2	5.03	1.125	1.24	2.25	1/4 Sq.

Motor Frame	33		34		35	
	Center Distance		Center Distance		Center Distance	
	Min.	Max.	Min.	Max.	Min.	Max.
56	12.28	18.25	12.31	18.28	-	-
143T/145T	12.28	18.25	12.31	18.28	13.87	19.34
182T/184T	13.28	19.25	13.31	19.28	14.87	20.34
213T/215T	-	-	14.06	20.03	15.62	21.09
254T/256T	-	-	-	-	16.62	22.09

¹ Dimension "D" will never be exceeded, but may vary from values shown. When exact dimensions are required, shims up to .03" may be necessary.
² All rough casting dimensions may vary by .25" due to casting variations.
³ Driven shaft entry can be from either side of the gear reducer housing by reversing positioning of the snap rings and washer illustrated.
⁴ Output finished bore tolerance: +.0020", -.0000 for all diameters.

⁵ Output key supplied only on frame 34 "S2" version.
⁶ Input shaft extension tolerances: +.0000"; -.0005" up to 1.5" diameter. Larger diameter "U1", +.000"; -.001".
⁷ Refer to Tapered Bushed designs if driven shaft varies from "U" dimensions offered above.
⁸ For details of the torque arm kit, refer to page B-114.

3-Stage Finished Bore Hollow Shaft Face Mount OtN33 - 35

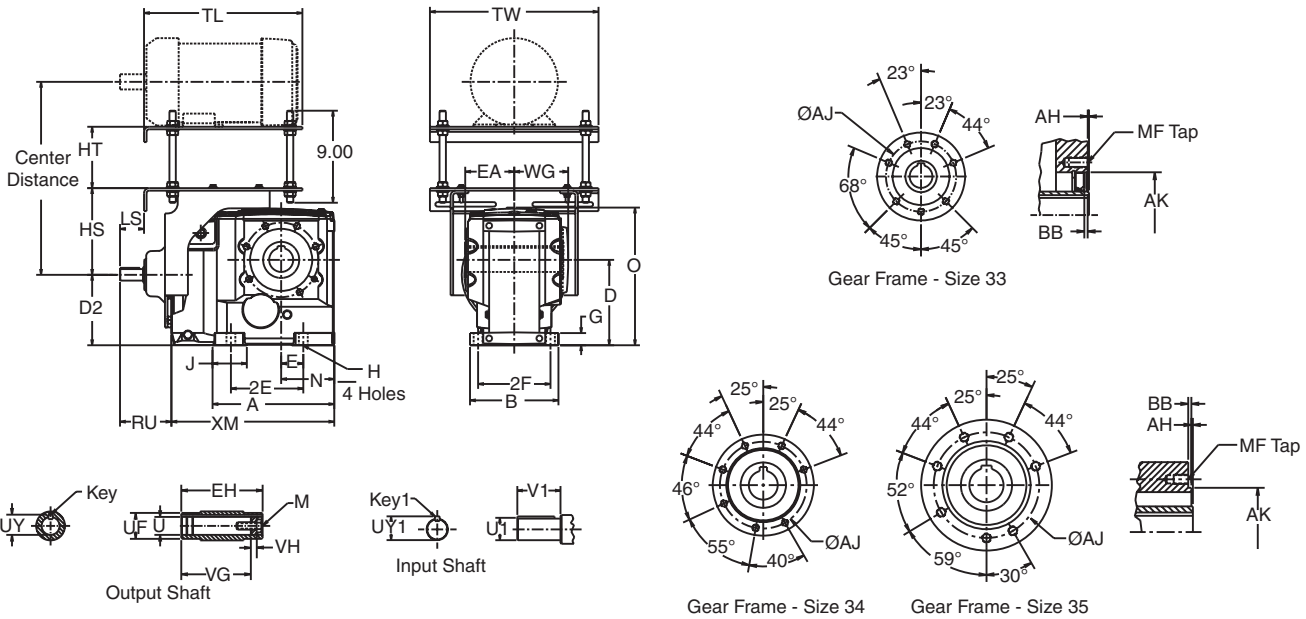

Gear Frame	Version	A	B	D ¹	D2	E	2E	2F	G	H	J	O	N	WG	XM	LS	HS	HT	TL	TW
33	S2	8.50	6.61	5.51	5.24	1.18	4.72	5.51	.85	.55	2.86	9.69	3.54	3.63	11.97	1.29	7.14	6.00	15.50	16.50
34	S2	10.13	7.87	7.09	5.90	1.57	5.91	6.50	1.07	.71	2.67	12.05	4.49	4.66	13.78	2.31	7.17	6.00	15.50	16.50
35	S2	11.92	8.66	8.35	6.89	2.17	7.09	7.09	1.18	.87	3.45	13.58	5.20	5.15	15.95	2.35	8.48	6.00	15.50	16.50

Output Shaft

Gear Frame	Version	EA	EH	U ⁵	UF	UY	VG	VH	Key ⁴	M
33	S2	3.47	6.94	1.500	2.16	1.674	5.96	.55	3/8 X 3/8 X 2 1/4	5/8-11 X 1.75
34	S2	4.49	8.97	2.000	2.56	2.210	7.44	.79	1/2 X 7/16 X 2 5/8	5/8-11 X 1.75
35	S2	4.83	9.66	2.375	3.54	2.638	8.15	.94	5/8 X 5/8 X 3 5/8	3/4-10 X 2.00

Output Face

Gear Frame	Version	AH	AJ	AK	BB	MF
33	S2	.12	4.84	3.94	.16	M12 X .87
34	S2	.14	5.98	5.12	.28	M10 X .87
35	S2	.13	7.48	6.10	.28	M12 X .87

Input Shaft

Gear Frame	Version	RU	U1 ⁶	UY1	V1	Key1
33	S2	3.17	.625	.705	1.25	3/16 Sq.
34	S2	4.75	1.125	1.236	2.25	1/4 Sq.
35	S2	5.03	1.125	1.236	2.25	1/4 Sq.

Motor Frame	33		34		35	
	Center Distance		Center Distance		Center Distance	
	Min.	Max.	Min.	Max.	Min.	Max.
56	12.28	18.25	12.31	18.28	-	-
143T/145T	12.28	18.25	12.31	18.28	13.87	19.34
182T/184T	13.28	19.25	13.31	19.28	14.87	20.34
213T/215T	-	-	14.06	20.03	15.62	21.09
254T/256T	-	-	-	-	16.62	22.09

¹ Dimension "D" will never be exceeded, but may vary from values shown. When exact dimensions are required, shims up to .03" may be necessary.
² All rough casting dimensions may vary by .25" due to casting variations.
³ Driven shaft entry can be from either side of the gear reducer housing by reversing positioning of the snap rings and washer illustrated.

⁴ Output key supplied only on frame 34 "S2" version.
⁵ Output finished bore tolerance: +.0020", -.0000 for all diameters.
⁶ Input shaft extension tolerances: +.0000"; -.0005" up to 1.5" diameter. Larger diameter "U1", +.000"; -.001".

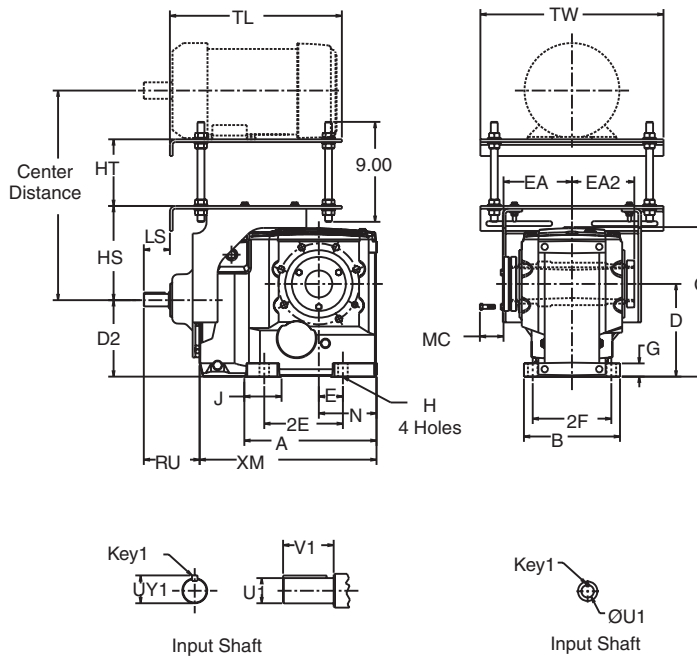

Gear Frame	Version	A	B	D ¹	D2	E	2E	2F	G	H	J	O	N	XM	LS	HS	HT	TL	TW
33	S2	8.50	6.61	5.51	5.24	1.18	4.72	5.51	.85	.55	2.86	9.69	3.54	11.97	1.29	7.14	6.00	15.50	16.50
34	S2	10.13	7.87	7.09	5.90	1.57	5.91	6.50	1.07	.71	2.67	12.05	4.49	13.78	2.31	7.17	6.00	15.50	16.50
35	S2	11.92	8.66	8.35	6.89	2.17	7.09	7.09	1.18	.87	3.45	13.58	5.20	15.95	2.35	8.48	6.00	15.50	16.50

Output Shaft

Gear Frame	Version	EA	EA2	MC ⁵	Bushing Bores ⁴	
					Min.	Max.
33	S2	4.82	4.23	1.75	3/4	1 7/16
34	S2	5.84	5.27	1.88	15/16	1 15/16
35	S2	6.17	5.620	1.88	1 3/8	2 7/16

Input Shaft

Gear Frame	Version	RU	U1 ³	UY1	V1	Key1
33	S2	3.17	.625	.70	1.25	3/16 Sq.
34	S2	4.75	1.125	1.24	2.25	1/4 Sq.
35	S2	5.03	1.125	1.24	2.25	1/4 Sq.

Motor Frame	33		34		35	
	Center Distance		Center Distance		Center Distance	
	Min.	Max.	Min.	Max.	Min.	Max.
56	12.28	18.25	12.31	18.28	-	-
143T/145T	12.28	18.25	12.31	18.28	13.87	19.34
182T/184T	13.28	19.26	13.31	19.28	14.87	20.34
213T/215T	-	-	14.06	20.03	15.62	21.09
254T/256T	-	-	-	-	16.62	22.09

¹ Dimension "D" will never be exceeded, but may vary from values shown. When exact dimensions are required, shims up to .03" may be necessary.
² All rough casting dimensions may vary by .25" due to casting variations.
³ Input shaft extension tolerances: +.0000"; -.0005" for shafts up to 1.5" diameter. Larger diameter "U1", +.000"; -.001".
⁴ Refer to page B-116 by gear frame for listing of all inch and metric bushing bore sizes available.

⁵ The MC dimension shows spacing required to install or remove the bushing from the reducer.
⁶ Bushing and dust cap can be installed opposite of how they are shown above.
⁷ Driven shaft entry can be from either side of the gear reducer housing. Refer to installation manual for requirements.
⁸ For details of the torque arm kit, refer to page B-22.

C-Face Reducers

Gear Frame	Reduction Stages	Input Size						
		56C	140TC	180TC	210TC	250TC	280TC	320TC
32	3	56	56	62	-	-	-	-
	5	64	64	-	-	-	-	-
33	3	68	68	77	77	-	-	-
	5,6	98	98	-	-	-	-	-
34	3	118	118	127	127	-	-	-
	5,6	147	147	-	-	-	-	-
35	3	190	190	199	199	204	206	-
	5,6	210	210	219	-	-	-	-
26	3	-	351	360	360	365	367	-
	5,6	401	401	419	419	-	-	-
27	3	-	-	540	540	545	547	575
	5,6	576	576	585	585	-	-	-
28	3	-	-	-	850	855	857	885
	5,6	860	860	869	869	-	-	-

Input Shaft Reducers

Gear Frame	Reduction Stages	Style		
		AP/AD	Scoop	Top Mt.
32	3	52	-	-
	5	60	-	-
33	3	74	99	121
	5,6	104	-	-
34	3	123	156	170
	5,6	151	-	-
35	3	195	247	266
	5,6	215	-	-
26	3	363	405	RO
	5,6	415	448	462
27	3	558	578	RO
	5,6	602	635	649
28	3	770	863	RO
	5,6	789	841	859

Gear Options Additional Weight

Gear Frame	Flange Mount	Footed S1
32	4	-
33	5	2
34	7	3
35	8	5
26	10	-
27	12	-
28	15	-

RO Refer to Application Engineering



Lubrication

Series 3000 OtN gearing is shipped with one of the following synthetic lubricants per the table below and fitted with a magnetic drain. Each reducer is filled according to the mounting position specified when ordered. Refer to unit nameplate and the chart on page B-16 or B-110 for mounting position arrangement for your unit.

In the case of synthetic oil, the lubricant does not require changing but it is recommended that proper oil level be checked periodically.

Standard Synthetic Gear Oil

No Backstop	
Manufacturer	-25° F to 125° F (-30° C to 50° C)
Fuchs®	Sintogear® 125
Mobil®	Mobilgear® SHC 150
Shell®	Omala® Fluids HD 150

With Backstop (1)	
Manufacturer	-25° F to 125° F (-30° C to 50° C)
Shell	Omala RL 100

- CAUTION** :
- Never mix synthetic oil and mineral oil.
 - (1) Never use extreme pressure (EP) oil in a reducer with a backstop.

Acceptable Mineral Oil Lubricants

Ambient Range of Installation				
-4°F to 14°F (-20°C to 10°C)	14°F to 122°F (-10°C to 50°C)			122°F and Above (50°C +)
	No Backstop		With Backstop (1)	
ISO VG 68	ISO VG 100	ISO VG 150	ISO VG 220	ISO VG 320

Foot Mounted Triple Reduction Designs - US Quarts (Litre = Quart x .946)

Gear Frame Size	Mounting Config.	Mounting Position					
		B	P	H	T	V	W
3243	S2, S1	0.55	1.82	1.50	1.50	2.00	1.40
3363	S2	1.16	3.70	3.49	2.96	3.96	2.75
	S1	3.70	1.16	2.96	3.49	3.96	2.75
3473	S2	1.37	6.34	4.76	4.65	5.39	3.91
	S1	6.34	1.37	4.65	4.76	5.39	3.91
3583	S2	2.85	10.25	5.39	7.72	11.42	6.61
	S1	10.25	2.85	7.72	5.39	11.42	6.61
2603	S1	4.50	28.50	28.50	28.50	30.00	16.00
2703	S1	6.00	39.00	37.00	40.00	42.00	21.00
2803	S1	11.50	78.00	76.00	82.50	83.00	72.50

Face, Flange or Shaft Mounted Triple Reduction Designs - US Quarts (Litre = Quart x .946)

Gear Frame Size	Mounting Config.	Mounting Position					
		B	P	H	T	V	W
3243	S2, S1	0.55	1.82	1.50	1.50	2.00	1.40
3363	S2, S1	1.16	3.70	3.49	2.96	3.96	2.75
3473	S2, S1	1.37	6.34	4.76	4.65	5.39	3.91
3583	S2, S1	2.85	10.25	5.39	7.72	11.42	6.61
2603	S1	4.50	28.50	28.50	28.50	30.00	16.00
2703	S1	6.00	39.00	37.00	40.00	42.00	21.00
2803	S1	11.50	78.00	76.00	82.50	83.00	72.50

Combined OtN Gear Designs - US Quarts (Litre = Quart x .946)

Gear Frame Size	Secondary Gearhead	Mounting Position											
		B		P		H		T		V		W	
		Prim.	Sec.	Prim.	Sec.	Prim.	Sec.	Prim.	Sec.	Prim.	Sec.	Prim.	Sec.
3245	CbN 30	**	0.46	**	0.46	**	0.46	**	0.46	**	0.46	**	0.46
3365	CbN 31	**	0.63	**	1.16	**	0.90	**	1.00	**	1.22	**	1.48
3365A	CbN 30	**	0.46	**	0.46	**	0.46	**	0.46	**	0.46	**	0.46
3475/3476	CbN 31	**	0.63	**	1.16	**	0.90	**	1.00	**	1.22	**	1.48
3585/3586	CbN 31	**	0.63	**	1.16	**	0.90	**	1.00	**	1.22	**	1.48
2605A	CbN 33	**	1.69	**	4.76	**	3.12	**	3.49	**	4.76	**	4.65
2606A	CbN 33	**	1.69	**	4.76	**	3.12	**	4.62	**	4.76	**	4.65
2705A	CbN 33	**	1.69	**	4.76	**	3.12	**	3.49	**	4.76	**	4.65
2706A	CbN 33	**	1.69	**	4.76	**	3.12	**	4.62	**	4.76	**	4.65
2803A	CbN 34	**	2.32	**	7.93	**	4.97	**	5.39	**	8.24	**	7.82
2806A	CbN 34	**	2.32	**	7.93	**	4.97	**	6.97	**	8.24	**	7.82

** Refer to tables above for three stage OtN oil volume based on frame size, mounting configuration, mounting position and type of mounting (i.e Foot, Flange,, etc.) of unit ordered.

The trade names, trademarks and/or registered trademarks that follow are used in this material by Emerson Power Transmission Corporation for comparison purposes, are NOT owned or controlled by Emerson Power Transmission Corporation and are believed to be owned by the parties identified: Fuchs and Sintogear: Fuchs Corporation; Shell and Omala: Shell Petroleum Incorporated; Mobil and Mobilgear: Exxonmobil Oil Corporation.

Emerson Power Transmission Corporation cannot and does not represent or warrant the accuracy of this information.

Experience the Power of EPT Edge Online

EPT Edge Online is our online
technical support center.

Also available "24-7-365," these electronic tools provide for efficient drive design and product selection:

- **eCatalog (an industry first)** - an interactive, robust electronic "database" with over 100,000 part numbers searchable by part number or general description providing features and benefits of each product line
- **Product Selection (an industry first)** - selection tools with extensive engineering efficiency benefits
- **Smart Interchange** - a dynamic tool that provides the user an intelligent interchange for competitive parts
- **Media Library** - digital (PDF) version of paper catalogs, documents, and downloadable installation and maintenance instructions
- **CAD** - an online service that allows users to view and upload a 2D or 3D CAD template drawing in a number of customer-compatible formats to be integrated into your drawings



www.emerson-ept.com

Connect Here To Be Part of Something Bigger





Gearmotor

SERIES 2000 3000

Typical Motor Performance Data

Motor Type MT 4 Pole TEFC - Standard Efficiency 230/460 VAC, 3/60

HP	Frame	Model	Full Load rpm	FL Amps @460V	Motor Efficiency (%)				Output Torque			KVA Code	NEMA Design
					Typical			Guar.	FL	% of Full Load			
					1/2 Load	3/4 Load	4/4 Load	4/4 Load		Ft. Lbs.	Locked		
0.33	56	E177	1745	0.6	65.1	71.1	72.0	68.0	1.0	239	349	K	B
	48	E522	1740	0.86	43.3	50.8	58.2	-	1.0	383	465	-	B
0.50	56	E180	1740	0.9	67.7	73.0	74.0	70.0	1.5	250	355	K	B
	48	E524		1.12	54.6	63.8	68.4	-	1.5	394	463	-	B
0.75	56	E183	1750	1.4	68.9	74.7	75.5	72.0	2.3	316	434	L	B
	48	E526	1730	1.36	63.9	70.8	73.4	-	2.3	350	405	-	B
1.0	143T	E186	1750	1.7	73.1	78.1	80.0	77.0	3.0	372	485	M	C
	48	F548	1733	1.8	68.0	74.3	77.4	-	3.0	458	495	-	C
1.5	145T	E188	1735	2.4	76.4	79.9	80.0	77.0	4.5	315	406	K	C
2.0	145T	E190	1725	3.1	79.3	81.9	80.0	77.0	6.1	310	390	L	C
2.5	145TY	E680	1730	4	78.2	81.5	80.0	77.0	7.6	370	450	L	B
3	182T	E192	1745	4.2	83.2	85.2	84.0	81.5	9.0	246	344	J	B
	145TY	F710	1730	4.5	81.3	83.7	82.5	80.0	9.0	382	466	L	B
5	182T	E194	1745	6.8	85.1	86.3	84.0	81.5	15.0	220	323	J	B
7.5	213T	E497	1750	10.1	85.6	87.0	86.5	84.0	22.5	230	290	H	B
10	215T	E498	1755	13.2	87.4	88.4	88.5	86.5	30	230	280	H	B
15	254T	E507	1770	18.9	88.2	89.4	88.5	86.5	45	210	260	G	B
20	256T	E508	1765	24.7	89.7	90.4	89.5	87.5	60	210	250	G	C
25	A284T	E608	1770	30	92.3	92.7	91.0	89.5	75	220	220	G	C
30	A286T	E609	1765	37	91.4	91.7	91.0	89.5	90	220	210	G	C

Motor Type MB 4 Pole TEFC - Standard Efficiency - 230/460 VAC, 3/60

HP	Frame	Model	Full Load rpm	FL Amps @460V	Motor Efficiency (%)				Output Torque			KVA Code	NEMA Design
					Typical			Guar.	FL	% of Full Load			
					1/2 Load	3/4 Load	4/4 Load	4/4 Load		Ft. Lbs.	Locked		
40	324T	G191	1775	46	94.5	94.5	93.6	92.4	120	170	228	F	B
50	326T	G193	1775	56	95.1	95.0	94.1	93.0	150	189	239	F	B

Motor Type MO 6 Pole TEFC - Standard Efficiency - 230/460 VAC, 3/60

HP	Frame	Model	Full Load rpm	FL Amps @460V	Motor Efficiency (%)				Output Torque			KVA Code	NEMA Design
					Typical			Guar.	FL	% of Full Load			
					1/2 Load	3/4 Load	4/4 Load	4/4 Load		Ft. Lbs.	Locked		
0.33	56	E178	1150	0.7	68.7	73.5	74.0	70.0	1.5	210	290	J	B
0.5	56	E181	1150	1.1	65.0	70.6	72.0	68.0	2.3	316	434	L	B
0.75	143T	E184	1155	1.6	66.6	72.0	72.0	68.0	3.4	250	330	K	B
1.0	145T	E501	1145	2	72.5	76.6	77.0	74.0	4.6	290	360	K	C
1.5	145T	E502	1160	2.9	73.4	77.7	78.5	75.5	6.8	310	390	K	C
2.0	182T	E503	1160	3.6	76.3	80.0	80.0	77.0	9	340	420	L	C
3	184T	E495	1165	4.9	81.4	83.6	82.5	80.0	13.5	210	260	H	B
5	213T	E396	1170	5	81.6	84.3	84.0	81.5	23	240	300	J	B
7.5	215T	S701	1170	9.9	86.9	88.3	87.5	85.5	34	190	264	G	B
10	254T	S702	1170	12.9	88.4	89.0	87.5	85.5	45	171	240	F	B

Meet or exceed NRCAN required efficiency. Design C ratings are exempt from this regulation.
 Note: For 575 VAC motors, use typical data above except current. For 575 V current multiply 460 V value by 0.80.



Gearmotor

**SERIES 2000
3000**

Typical Motor Performance Data

Motor Type MI
4 Pole TEFC - Varidyne Inverter Duty - 230/460 VAC, 3/60

HP	Frame	Model	Full Load rpm @ 60 Hz	FL Amps @460V	Motor Efficiency (%)				Output Torque			KVA Code
					Typical			Guar.	FL	% of Full Load		
					1/2 Load	3/4 Load	4/4 Load	4/4 Load	Ft. Lbs.	Locked	Breakdown	
0.33	56	G591	1765	0.8	61.2	69.2	74.0	70.0	1	528	694	R
0.5	56	G592	1770	1.2	64.5	72.2	75.5	72.0	1.5	555	721	R
0.75	56	G593	1760	1.3	73.6	79.0	81.5	78.5	2.2	488	622	P
1.0	143T	G595	1755	1.7	76.5	81.0	82.5	80.0	3	446	567	N
1.5	145T	G596	1740	2.3	79.0	82.3	82.5	80.0	4.5	365	458	L
2.0	145TY	G596	1735	2.8	84.2	86.2	85.5	82.5	6	360	440	L

Motor Type MY, MI
4 Pole TEFC - 230/460 VAC, 3/60

HP	Frame	Model	Full Load rpm	FL Amps @460V	Motor Efficiency (%)				Output Torque			KVA Code	NEMA Design
					Typical			Guar.	FL	% of Full Load			
					1/2 Load	3/4 Load	4/4 Load	4/4 Load	Ft. Lbs.	Locked	Breakdown		
3	182T	G597	1760	4	86.9	88.7	88.5	86.5	9	249	376	K	B
5	184T	G598	1750	6.4	89.9	90.4	88.5	86.5	15	234	340	J	B
7.5	213T	G84980	1765	7.1	90.9	91.4	90.2	88.5	22.3	220	290	J	B
10	215T	G84982	1760	12	91.9	91.9	90.2	88.5	30	211	270	G	B
15	254T	G83983	1775	19	93.1	93.4	92.4	91	45	228	244	G	B
20	256T	G84991	1770	24	94	94	93	91.7	60	229	233	G	B
25	284T	G417	1775	29.3	93.8	94.0	93.6	92.4	75	180	250	G	B
30	286T	G519	1775	35	94.4	94.6	94.1	93.0	90	190	250	G	B
40	324T	G191	1775	46	94.5	94.5	93.6	92.4	120	170	228	F	B
50	326T	G193	1775	56	95.1	95.0	94.1	93.0	150	189	239	F	B

Motor Type MZ
4 Pole TEFC - Premium Efficiency - 575 VAC, 3/60

HP	Frame	Model	Full Load rpm	FL Amps @575V	Motor Efficiency (%)				Output Torque			KVA Code	NEMA Design
					Typical			Guar.	FL	% of Full Load			
					1/2 Load	3/4 Load	4/4 Load	4/4 Load	Ft. Lbs.	Locked	Breakdown		
1.5	145T	AD93	1740	1.8	80.5	83.5	84.0	81.5	4.5	375	467	L	B
2.0	145T	AD94	1725	2.3	83.4	85.0	84.0	81.5	6	333	409	K	B
3	182T	J793	1760	3.2	87.2	88.8	88.5	86.5	9	253	380	K	B
5	184T	J794	1750	5.2	90.1	90.5	88.5	86.5	15	244	348	H	B
7.5	213T	J795	1765	7.3	91.5	92.0	91.0	89.5	22.3	230	300	H	B
10	215T	J796	1760	9.5	92.5	92.6	91.0	89.5	30	220	280	H	B
15	254T	J797	1775	14.6	93.1	93.4	91.7	90.2	45	220	240	G	B
20	256T	J798	1770	19	94.1	94.1	92.4	91.0	60	220	230	G	B
25	284T	G518	1775	23.4	93.8	94.0	93.0	91.7	75	180	250	G	B
30	286T	G520	1775	27.6	94.4	94.5	93.6	92.4	90	190	250	G	B
40	324T	G192	1775	37	94.5	94.5	93.6	92.4	120	180	237	F	B
50	326T	G194	1775	45	95.2	95.0	94.1	93.0	150	180	28	F	B

Meet or exceed NRCan required efficiency. Design C ratings are exempt from this regulation.

Typical Motor Performance Data

Motor Type CI
4 Pole TEFC - Corro-Duty - 230/460 VAC, 3/60

HP	Frame	Model	Full Load rpm	FL Amps @460V	Motor Efficiency (%)				Output Torque			KVA Code
					Typical			Guar.	FL	% of Full Load		
					1/2 Load	3/4 Load	4/4 Load	4/4 Load	Ft. Lbs.	Locked	Breakdown	
0.33	56	BV25	1765	0.8	61.2	69.2	74	70	1	528	694	R
0.5	56	BV26	1770	1.2	64.5	72.2	75.5	72	1.5	555	721	R
0.75	56	BV27	1760	1.3	73.6	79	81.5	78.5	2.2	488	622	P
1.0	143T	BV28	1755	1.7	76.5	81	82.5	80	3	446	567	N
1.5	145T	BV29	1740	2.3	79	82.3	82.5	80	4.5	365	458	L
2.0	145T	BV30	1735	2.8	84.2	86.2	85.5	82.5	6	360	440	L
3	182T	G106	1760	4	88	89.5	89.5	87.5	9	240	370	K
5	184T	G107	1740	6.4	89.9	90.4	88.5	86.5	15	234	340	J
7.5	213T	G110	1765	9.2	91.4	92	91.7	90.2	22.3	240	310	H
10	215T	G112	1760	11.9	92.5	92.6	91	89.5	30	220	280	H
15	254T	G114	1775	18.4	93	93.4	92.4	91	45	230	240	G
20	256T	G115	1770	23.7	94.2	94.3	93	91.7	60	229	232	G

Motor Type MC
4 Pole TEFC - Corro-Duty - 230/460 VAC, 3/60

HP	Frame	Model	Full Load rpm	FL Amps @460V	Motor Efficiency (%)				Output Torque			KVA Code	NEMA Design
					Typical			Guar.	FL	% of Full Load			
					1/2 Load	3/4 Load	4/4 Load	4/4 Load	Ft. Lbs.	Locked	Breakdown		
0.33	56	G116	1750	0.6	66.0	71.8	72.0	68.0	1	230	340	L	B
0.5	56	G133	1745	0.9	68.3	73.6	74.0	70.0	1.5	240	340	K	B
0.75	56	G121	1750	1.4	69.3	75.1	77.0	74.0	2.2	300	420	M	B
1.0	143T	G125	1750	1.6	73.9	78.7	80.0	77.0	3	360	460	M	C
1.5	145T	G127	1735	1.9	76.5	80.0	80.0	77.0	4.5	300	390	K	C
2.0	145T	G128	1725	2.4	80.1	82.7	82.5	80.0	6	330	410	K	C
3	182T	G106	1760	4	88.0	89.5	89.5	87.5	9	240	370	K	B
5	184T	G107	1740	6.4	89.9	90.4	88.5	*86.5	15	234	340	J	B
7.5	213T	G110	1765	9.2	91.4	92.0	91.7	90.2	22.3	240	310	H	B
10	215T	G112	1760	11.9	92.5	92.6	91.0	89.5	30	220	280	H	B
15	254T	G114	1775	18.4	93.0	93.4	92.4	91.0	45	230	240	G	B
20	256T	G115	1770	23.7	94.2	94.3	93.0	91.7	60	229	232	G	B
25	284T	G520	1775	25	93.8	94.0	93.0	91.7	75	180	250	G	B
30	286T	G520	1775	27.6	94.4	94.5	93.6	92.4	90	190	250	G	B

Motor Type MG
4 Pole - Corro-Duty - 575 VAC, 3/60

HP	Frame	Model	Full Load rpm	FL Amps @575V	Motor Efficiency (%)				Output Torque			KVA Code	NEMA Design
					Typical			Guar.	FL	% of Full Load			
					1/2 Load	3/4 Load	4/4 Load	4/4 Load	Ft. Lbs.	Locked	Breakdown		
0.33	56	G118	1750	0.5	66.5	72.5	74.0	70.0	1	250	370	L	B
0.5	56	G120	1750	0.7	67.7	73.6	75.5	72.0	1.5	270	390	K	B
0.75	56	G123	1750	1.1	69.2	75.0	77.0	74.0	2.2	300	420	M	B
1.0	143T	AD95	1755	1.3	77.0	81.4	82.5	80.0	3	428	541	N	C
1.5	145T	AD96	1740	1.8	80.4	83.5	84.0	81.5	4.5	375	466	L	C
2.0	145T	AD97	1725	2.3	83.4	85.1	84.0	81.5	6	330	410	K	C
3	182T	G182	1760	3.2	87.2	88.8	88.5	86.5	9	253	380	K	B
5	184T	G183	1740	5	90.7	90.2	87.5	85.5	15	170	260	H	B
7.5	213T	G186	1760	7.3	91.6	92.1	91.0	89.5	22.3	220	280	H	B
10	215T	G187	1760	9.6	92.5	92.6	91.0	89.5	30	210	270	H	B
15	254T	G146	1775	14.6	93.1	93.4	92.4	91.0	45	220	240	G	B
20	256T	G147	1770	19	94.1	94.2	93.0	91.7	60	220	230	G	B

Meet or exceed NRCAN required efficiency. Design C ratings are exempt from this regulation.

Typical Motor Performance Data

Motor Type MS
4 Pole TEFC - Single Phase - 115/230 VAC, 1/60

HP	Frame	Model	Full Load rpm	* FL Amps @230V	Motor Efficiency (%)			Output Torque		
					Typical			FL	% of Full Load	
					1/2 Load	3/4 Load	4/4 Load	Ft. Lbs.	Locked	Breakdown
0.17	48	E519	1725		34.1	42.2	47.7	8.1 oz-ft	404	321
0.25	48	E521	1725	2.1	45.3	53.7	58.9	12.2 oz-ft	371	291
0.33	56	E511	1730	3.2	47.2	55.2	58.7	1	366	262
	48	E523	1744	2.5	51.1	57.8	61.4	1	279	229
0.5	56	E512	1751	3.9	56.2	63.9	67.5	1.5	300	240
	48	E525	1740	3.6	59.7	66.2	69.0	1.5	279	229
0.75	56	E513	1744	4.9	65.4	70.4	71.7	2.28	325	255
	48	E527	1750	3.7	67.8	75.6	79.8	2.28	338	298
1.0	143T	E514	1739	6.7	66.2	71.4	73.0	3	279	250
1.5	145TY	E515	1725	6.5	72.4	79.1	81.7	4.5	288	290
2.0	145TY	E516	1725	8.1	77.9	85.2	89.7	6	247	320

Motor Type MR
4 Pole TEFC - Single Phase - 230 VAC, 1/60

HP	Frame	Model	Full Load rpm	FL Amps @230V	Motor Efficiency (%)			Output Torque		
					Typical			FL	% of Full Load	
					1/2 Load	3/4 Load	4/4 Load	Ft. Lbs.	Locked	Breakdown
3	184T	H03794	1760	17	66.5	79.8	78.1	9	450	330
5	184T	H03792	1740	24	67.8	81.3	79.4	15	400	275

* For dual voltage motors, 115V amps is twice 230V value shown.

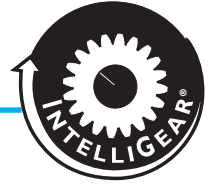

General Information

1 - General Information

1.1 - General operating principle

The IntelliGear is a combination of a 3-phase induction motor and an integrated variable speed drive. The motor can be combined with many gear types from Emerson Power Transmission’s range.

In the standard product version, the integrated drive does not require any connection other than the power supply. The options may be used to broaden the application range of the IntelliGear. Based on the advanced technology of the IGBT power module, very high efficiency and reduced noise levels are achieved.

1.2 - Product name

IntelliGear Range							
115V Single Phase Power Supply		230V Single Phase Power Supply		230V Three Phase Power Supply		460V Three Phase Power Supply	
Catalog Number	Motor HP	Catalog Number	Motor HP	Catalog Number	Motor HP	Catalog Number	Motor HP
I 21 M 033	0.33	I 21 M 033	0.33	I 21 033	0.33	I 21 033	0.33
I 22 M 050	0.50	I 21 M 050	0.50	I 21 050	0.50	I 21 050	0.50
I 22 M 075	0.75	I 21 M 075	0.75	I 21 075	0.75	I 21 075	0.75
		I 21 M 100	1.0	I 21 100	1.0	I 21 100	1.0
		I 22 M 150	1.5	I 22 150	1.5	I 21 150	1.5
		I 22 M 200	2.0	I 22 200	2.0	I 21 200	2.0
						I 22 300	3.0
						I 22 500	5.0

IntelliGear Speed Controlling Options	
Designation	Description
P1	Run/stop/control knob mounted on IntelliGear enclosure
P2	For./rev./stop/control knob mounted on IntelliGear enclosure
P3	Control knob (only) mounted on IntelliGear enclosure
P4	Speed potentiometer (only) mounted inside IntelliGear enclosure
R	Remote signal following (either 0-10VDC or 4-20mA)
RP	Controlled by fieldbus: Profibus DP
RI	Controlled by fieldbus: Interbus S
RD	Controlled by fieldbus: Devicenet

IntelliGear Options	
Part ID	Description
CDC ITG	IntelliGear parameter setting console w/3 meter cable
AEM904KA006	DC braking resistors 100W
AEM904KA005	DC braking resistors 200W
XS9900	Pegasus CD kit w/3 meter cable

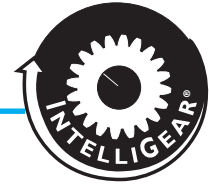

Variable Speed Gearmotors

1.3 - Characteristics

1.3.1 - Electrical Data

Single Phase Design

Power supply	115 V ± 10%, 50 - 60 Hz	230 V ± 10%, 50 - 60 Hz
Output voltage	From input voltage down to (input voltage/speed range)	
Power range	0.33, 0.50, 0.75 HP	0.33, 0.50, 0.75, 1.0, 1.5, 2.0 HP
Maximum numbers of power-ups per hour	10	

Three Phase Design

Power supply	230 V ± 10%, 50 - 60 Hz	460 V ± 10%, 50 - 60 Hz
Output voltage	From input voltage down to (input voltage/speed range)	
Power range	0.33, 0.50, 0.75, 1.0, 1.5, 2.0 HP	0.33, 0.50, 0.75, 1.0, 1.5, 2.0, 3.0, 5.0 HP
Maximum numbers of power-ups per hour	Unlimited	

1.3.2 - Characteristics and Functions

Characteristic	IntelliGear	
Overload	150 % of full load setting for 40 seconds, 10 times per hour	
Motor Frequency Variation Range	Standard	11 to 60 Hz and 6:1 constant torque up to 3 HP 12 to 74 Hz and 6:1 constant torque 5 HP
	Special	6 to 120 Hz range adjustable using console or software option
Efficiency	97.5 % x motor efficiency x gear efficiency	

Drive Control	IntelliGear	
Speed Reference	<ul style="list-style-type: none"> Analog reference (0V or 4mA = minimum speed) (10V or 20mA = maximum speed) <ul style="list-style-type: none"> - 0 to 10 VDC with control knob on IntelliGear enclosure (options P1,P2,P3) - 0 to 10 VDC with potentiometer in IntelliGear enclosure (option P4) - 0 to 10 VDC with customer signal * (option R) - 4 to 20 mA with customer signal * (option R) Digital reference <ul style="list-style-type: none"> - one to four preset speeds (accessible via console or software option) With fieldbus 	
	Process Control	
	Control of a process with the integrated PI loop (accessible with the console or software option) PI feedback sensor characteristics : 0 - 10V or 4 - 20 mA *	

* User adjust using mini-dip switches.

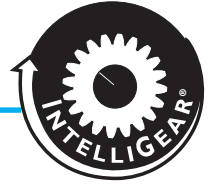

1.3.2 - Characteristics and Functions (cont'd.)

Drive Control	IntelliGear
Run/Stop	<ul style="list-style-type: none"> • With the three phase power supply • With remote dry contact • With integrated Run/Stop (option P1) • With fieldbus options
Forward/Reverse	<ul style="list-style-type: none"> • With internal lead connections to motor • With remote dry contact • With integrated For/Rev/Speed Knob control (option P2) • With fieldbus options
Stop Mode	<ul style="list-style-type: none"> • On ramp (with dry contact or integrated Run/Stop option P1) • Freewheel stop (by cutting controller input power) • Freewheel stop (with dry contact or integrated Run/Stop option P1, accessible with console or software. • With electro-mechanical brake
Ramps	<ul style="list-style-type: none"> • Selection of acceleration and deceleration ramps with dry contact: 1 or 3 seconds. (The factory setting is 3 seconds to 50 Hz.) • Ramps adjustable from 0 to 100 seconds to 50 Hz (accessible with console or software).
Fieldbus	PROFIBUS DP, DEVICENET

Indication	IntelliGear									
Indicator Lamps for Options P1, P2, P3, P4	<ul style="list-style-type: none"> • Steady green light = main power source connected • Flashing green light = overload • Flashing green and red lights = current limit • Flashing red light = over or undervoltage • Steady red light = other fault 									
Relay	• Drive fault (other specifics possible with console or software option**) dry contact - 1A - 250V - contact open, drive faulty or powered down									
Analog Output	<ul style="list-style-type: none"> • 0 to 10V, 3mA output <table style="width: 100%; border: none;"> <tr> <td style="text-align: center;"><u>Speed Indication</u></td> <td style="text-align: center;"><u>Current Indication**</u></td> <td style="text-align: center;"><u>Power Indication**</u></td> </tr> <tr> <td style="text-align: center;">0V = zero speed</td> <td style="text-align: center;">0V = 0 amps</td> <td style="text-align: center;">0V = 0 HP</td> </tr> <tr> <td style="text-align: center;">10V = max. speed</td> <td style="text-align: center;">10V = FL amps</td> <td style="text-align: center;">10V = Max. HP</td> </tr> </table>	<u>Speed Indication</u>	<u>Current Indication**</u>	<u>Power Indication**</u>	0V = zero speed	0V = 0 amps	0V = 0 HP	10V = max. speed	10V = FL amps	10V = Max. HP
<u>Speed Indication</u>	<u>Current Indication**</u>	<u>Power Indication**</u>								
0V = zero speed	0V = 0 amps	0V = 0 HP								
10V = max. speed	10V = FL amps	10V = Max. HP								

Protection	IntelliGear
Power	<ul style="list-style-type: none"> • Undervoltage • Overvoltage • Overloads: <ul style="list-style-type: none"> - overheating of drive and/or motor - protection against locked rotor • Short-circuit <ul style="list-style-type: none"> - motor windings
Control	• Short circuit on 0 - 10V - 24V inputs or outputs
Trip Clearance	• Via switching off the IntelliGear

* User adjust using the "mini-DIP" switch prior to start-up.
** Requires CDC-ITG console or Pegasus software option.

Characteristics	Level
Storage temperature	From -40C to +70C
Transport temperature	From -40C to +70C
Operating ambient temperature	From -20C to +40C (up to +50C with derating)
Altitude	Up to 3000 feet without derating
Ambient humidity	Without condensation
Vibration	Maximum acceleration 0.01 g ² /Hz
Shocks	Peak acceleration 20g
Immunity	Conforms to EN 50082-2
Radiated conducted emissions	Conforms to EN 50081
UL and cUL standard	Refer to UL File E211799
Enclosure options (motor and controller)	TEFC Version (TEFC and NEMA 4/12)
	Washdown Version* (Washdown and NEMA 4/12)

* C-Face motors

Variable Speed Gearmotors

2 - Faults - Diagnostics

Information relating to the status of the IntelliGear is provided by two indicator lamps located on the control options.

Color and state of indicator lamps	Reason for fault	Checks to be performed
Steady green	No fault Power present	If the motor does not rotate, check that: - terminals 1 and 3 are connected - a run command has actually been enabled: terminals 7 and 10 or 8 and 10 are connected
Flashing green and red	Current limiting	• Check that the motor is not overloaded or stalled
Flashing green	Overload	• The motor is overloaded: check the motor current using a clamp ammeter (section 6.2.2)
Steady red	<ul style="list-style-type: none"> • Short-circuit of a motor winding • Locked motor rotor • Faulty insulation of a winding • (I²T) overheating • Internal fault 	<ul style="list-style-type: none"> • Check that no incident has occurred • Switch off and then on again to clear the fault • Check that the deceleration ramp is long enough (5s) for applications with high inertia • If the fault remains, consult Emerson Power Transmission Technical Services
Flashing red	<ul style="list-style-type: none"> • Undervoltage • Overvoltage 	<ul style="list-style-type: none"> • Check the main voltage • Check that the deceleration ramp is long enough (5s) for applications with high inertia • Switch off and then on again

Trips can be cleared by switching off the IntelliGear.

3 - Operating Extensions

3.1 - Control knob with integrated run/stop control option (P1)

In addition to speed control, a run button and a stop button make it possible to control the IntelliGear locally, once it has been switched on, as required. For a run command to be taken into account, the button must be held down for one second.

- It is connected on the P2 connector.
- Has two indicator lights.



3.3 - Speed control knob option (P3)

The speed is set using a knob with graduations from 15 to 100 percent. Has two indicator lamps. It is connected on the P2 connector.



3.2 - Control knob with forward/reverse/stop control option (P2)

In addition to speed control, a forward button, a reverse button and a stop button make it possible to control the IntelliGear locally, once it has been switched on, as required. For a run command to be taken into account, the button must be held down for one second.

- Connected on the P2 connector
- Has two indicator lights



3.4 - Internal speed control option (P4)

The speeds are set on potentiometers, which are accessible once the cover has been removed.

- a max. spd potentiometer: calibration of the maximum speed
- a min. spd potentiometer: calibration of the minimum speed
- an int. spd potentiometer: speed control, which replaces control via the control knob.

There are also two indicator lights.



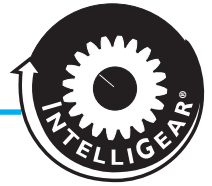

3.5 - Braking resistor option (RF100 - RF200)

For operation in four quadrants and energy dissipation, resistors are mounted directly onto the IntelliGear.



	RF100	RF200 (2x100)		Minimum ohmic value
	P peak kW	P peak kW	Resistor connection	
I21	5.6	2.8	series	100Ω
I21M	1.3	2.6	parallel	50Ω
I22	5.6	11.2	parallel	50Ω

RF100 = thermal power 100W

RF200 = thermal power 200W

External resistors with greater thermal power can be used, provided that the minimum ohmic value is maintained.

3.6 - Fieldbus options

The interface card is fixed inside the casing cover. Protocols: Profibus DP, Devicenet.

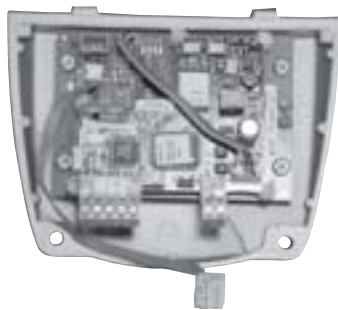

3.7 - Parameter-setting console option (CDC-ITG)

The console option provides access to the drive Internet settings (terminal block configuration, ramp, speed and P1 settings, etc.). See IntelliGear parameter-setting manual included.

Description of the option:

- 1 CDC-VMA console
- 1 cable (3m long)



3.8 - Pegasus Programming CD (XS9900)

This CD with manual provides access to the drive internal settings (terminal block configuration, range, speed and PI settings, etc.).

Descriptions of the option:

- 1 CD in case
- 1 cable (3m long)

3.9 - EMC filter option (FLT VMA21M)

The filter is mounted inside IntelliGear drive enclosure. The IntelliGear then conforms to standard EN 50081-1 (domestic level).

A Guide to NEMA Motor Frames and Shaft Dimensions

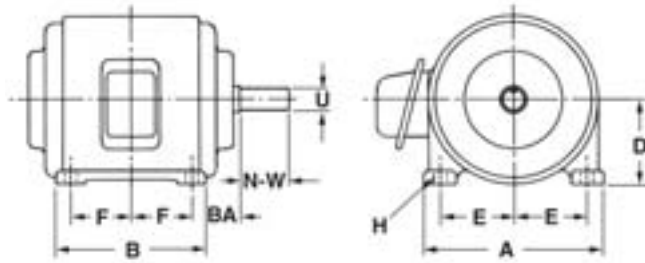

Motor ratings and dimensions shown in Table No. 1, below, are for general purpose motors as indicated. Frames for the 1952 - 1953 and the 1964 rerates are shown. All dimensions are subject to change without notice. Those shown are intended as a guide only. Certified dimension drawings from the motor manufacturer should be used.

Table No. 1 Specifications

Frame No.	Dimensions									Keyseat		Key Length	HP for Various Motor RPM			
	A Max.	B Max.	D	E	F	H	BA	N-W	U	Width	Depth		3600	1800	1200	900
Fractional Horsepower Motors																
48	5 3/8"	3 1/2"	3"	2 1/8"	1 3/8"	11/32" s ▲	2 1/2"	1 1/2"	1/2"	Flat	3/64"	-	1/8-1/2	1/8-1/3	1/6	-
56	6 1/2"	4 1/2"	3 1/2"	2 7/16"	1 1/2"	11/32" ▲	2 3/4"	1 7/8"	5/8"	3/16"	3/32"	1 3/8"	3/4-1	1/3-1	1/8-1/2"	-
1952-53 Rerate -- Designs A, B and C -- Open Type -- Squirrel Cage -- Integral H.P. Motors																
182	9	6 1/2"	4 1/2"	3 3/4"	2 1/4"	13/32"	2 3/4"	2 1/4"	7/8"	3/16"	3/32"	1 3/8"	1 1/2"	1	3/4	1/2
184	9	7 1/2"	4 1/2"	3 3/4"	2 3/4"	13/32"	2 3/4"	2 1/4"	7/8"	3/16"	3/32"	1 3/8"	3,2	2,1 1/2"	1 1/2,1	3/4
213	10 1/2"	7 1/2"	5 1/4"	4 1/4"	2 3/4"	13/32"	3 1/2"	3	1 1/8"	1/4"	1/8"	2	5	3	2	1 1/2,1
215	10 1/2"	9	5 1/4"	4 1/4"	3 1/2"	13/32"	3 1/2"	3	1 1/8"	1/4"	1/8"	2	7 1/2"	5	3	2
254U	12 1/2"	10 3/4"	6 1/4"	5	4 1/8"	17/32"	4 1/4"	3 3/4"	1 3/8"	5/16"	5/32"	2 3/4"	10	7 1/2"	5	3
256U	12 1/2"	12 1/2"	6 1/4"	5	5	17/32"	4 1/4"	3 3/4"	1 3/8"	5/16"	5/32"	2 3/4"	15	10	7 1/2"	5
284U	14	12 1/2"	7	5 1/2"	4 3/4"	17/32"	4 3/4"	4 7/8"	1 5/8"	3/8"	3/16"	3 3/4"	20	15	10	7 1/2"
286U	14	14	7	5 1/2"	5 1/2"	17/32"	4 3/4"	4 7/8"	1 5/8"	3/8"	3/16"	3 3/4"	25	20	10	10
324U	16	14	8	6 1/4"	5 1/4"	21/32"	5 1/4"	5 5/8"	1 7/8"	1/2"	1/4"	4 1/4"	-	25	15	-
324S*	16	14	8	6 1/4"	5 1/4"	21/32"	5 1/4"	3 1/4"	1 5/8"	3/8"	3/16"	1 7/8"	30	-	-	-
326U	16	15 1/2"	8	6 1/4"	6	21/32"	5 1/4"	5 5/8"	1 7/8"	1/2"	1/4"	4 1/4"	-	30	20	15
326S*	16	15 1/2"	8	6 1/4"	6	21/32"	5 1/4"	3 1/4"	1 5/8"	3/8"	3/16"	1 7/8"	40	-	-	-
364U	18	15 1/4"	9	7	5 5/8"	21/32"	5 7/8"	6 3/8"	2 1/8"	1/2"	1/4"	5	-	40	25	20
364US*	18	15 1/4"	9	7	5 5/8"	21/32"	5 7/8"	3 3/4"	1 7/8"	1/2"	1/4"	2	50	-	-	-
365U	18	16 1/4"	9	7	6 1/8"	21/32"	5 7/8"	6 3/8"	2 1/8"	1/2"	1/4"	5	-	-	30	25
365US*	18	16 1/4"	9	7	6 1/8"	21/32"	5 7/8"	3 3/4"	1 7/8"	1/2"	1/4"	2	60	50	-	-
404U	20	16 1/4"	10	8	6 1/8"	13/16"	6 5/8"	7 1/8"	2 3/8"	5/8"	5/16"	5 1/2"	-	40	30	30
404US*	20	16 1/4"	10	8	6 1/8"	13/16"	6 5/8"	4 1/4"	2 1/8"	1/2"	1/4"	2 3/4"	75	60	-	-
405U	20	17 3/4"	10	8	6 7/8"	13/16"	6 5/8"	7 1/8"	2 3/8"	5/8"	5/16"	5 1/2"	-	-	50	40
405US*	20	17 3/4"	10	8	6 7/8"	13/16"	6 5/8"	4 1/4"	2 1/8"	1/2"	1/4"	2 3/4"	100	75	-	-
444U	22	1	11	9	7 1/4"	13/16"	7 1/2"	8 5/8"	2 3/8"	3/4"	3/8"	7	-	60	50	50
444US*	22	18 1/2"	11	9	7 1/4"	13/16"	7 1/2"	4 1/4"	2 1/8"	1/2"	1/4"	2 3/4"	125	100	-	-
445U	22	20 1/2"	11	9	8 1/4"	13/16"	7 1/2"	8 5/8"	2 3/8"	3/4"	3/8"	7	-	75	60	60
445US*	22	20 1/2"	11	9	8 1/4"	13/16"	7 1/2"	4 1/4"	2 1/8"	1/2"	1/4"	2 3/4"	150	125	-	-
1964 Rerate -- Designs A, B and C -- Open Type -- Squirrel Cage -- Integral H.P. Motors																
H143T	7	6	3 1/2"	2 3/4"	2	11/32"	2 1/4"	2 1/4"	7/8"	3/16"	3/32"	1 3/8"	1 1/2"	1	3/4	1/2
H145T	7	6	3 1/2"	2 3/4"	2 1/4"	11/32"	2 1/4"	2 1/4"	7/8"	3/16"	3/32"	1 3/8"	-	1 1/2"	1	3/4
K145T	7	6	3 1/2"	2 3/4"	2 1/2"	11/32"	2 1/4"	2 1/4"	7/8"	3/16"	3/32"	1 3/8"	3,2	2	2	3/4
182T	9	6 1/2"	4 1/2"	3 3/4"	2 1/4"	13/32"	2 3/4"	2 3/4"	1 1/8"	1/4"	1/8"	1 3/4"	5	3	1 1/2"	1
184T	9	7 1/2"	4 1/2"	3 3/4"	2 3/4"	13/32"	2 3/4"	2 3/4"	1 1/8"	1/4"	1/8"	1 3/4"	7 1/2"	5	2	1 1/2"
213T	10 1/2"	7 1/2"	5 1/4"	4 1/4"	2 3/4"	13/32"	3 1/2"	33/8"	1 3/8"	5/16"	5/32"	2 3/8"	10	7 1/2"	3	2
215T	10 1/2"	9	5 1/4"	4 1/4"	3 1/2"	13/32"	3 1/2"	33/8"	1 3/8"	5/16"	5/32"	2 3/8"	15	10	5	3
254T	12 1/2"	10 3/4"	6 1/4"	5	4 1/8"	17/32"	4 1/4"	4	1 5/8"	3/8"	3/16"	2 7/8"	20	15	7 1/2"	5
256T	12 1/2"	12 1/2"	6 1/4"	5	5	17/32"	4 1/4"	4	1 5/8"	3/8"	3/16"	2 7/8"	25	20	10	7 1/2"
284T	14	12 1/2"	7	5 1/2"	4 3/4"	17/32"	4 3/4"	4 5/8"	1 7/8"	1/2"	1/4"	3 1/4"	-	25	15	10
284TS*	14	12 1/2"	7	5 1/2"	4 3/4"	17/32"	4 3/4"	3 1/4"	1 5/8"	3/8"	3/16"	1 7/8"	30	-	-	-
286T	14	14	7	5 1/2"	5 1/2"	17/32"	4 3/4"	4 5/8"	1 7/8"	1/2"	1/4"	3 1/4"	-	30	20	15
286TS*	14	14	7	5 1/2"	5 1/2"	17/32"	4 3/4"	3 1/4"	1 5/8"	3/8"	3/16"	1 7/8"	40	-	-	-
324T	16	14	8	6 1/4"	5 1/4"	21/32"	5 1/4"	5 1/4"	2 1/8"	1/2"	1/4"	3 7/8"	-	40	25	20
324TS*	16	14	8	6 1/4"	5 1/4"	21/32"	5 1/4"	3 3/4"	1 7/8"	1/2"	1/4"	2	50	-	-	-
326T	16	15 1/2"	8	6 1/4"	6	21/32"	5 1/4"	5 1/4"	2 1/8"	1/2"	1/4"	3 7/8"	-	50	30	25
326TS*	16	15 1/2"	8	6 1/4"	6	21/32"	5 1/4"	3 3/4"	1 7/8"	1/2"	1/4"	2	60	-	-	-
364T	18	15 1/4"	9	7	5 5/8"	21/32"	5 7/8"	5 7/8"	2 3/8"	5/8"	5/16"	4 1/4"	-	60	40	30
364TS*	18	15 1/4"	9	7	5 5/8"	21/32"	5 7/8"	3 3/4"	1 7/8"	1/2"	1/4"	2	75	-	-	-
365T	18	16 1/4"	9	7	6 1/8"	21/32"	5 7/8"	5 7/8"	2 3/8"	5/8"	5/16"	4 1/4"	-	75	50	40
365TS*	18	16 1/4"	9	7	6 1/8"	21/32"	5 7/8"	3 3/4"	1 7/8"	1/2"	1/4"	2	100	-	-	-
404T	20	16 1/4"	10	8	6 1/8"	13/16"	6 5/8"	7 1/4"	2 7/8"	3/4"	3/8"	5 5/8"	-	100	60	50
404TS*	20	16 1/4"	10	8	6 1/8"	13/16"	6 5/8"	4 1/4"	2 1/8"	1/2"	1/4"	2 3/4"	125	-	-	-
405T	20	17 3/4"	10	8	6 7/8"	13/16"	6 5/8"	7 1/4"	2 7/8"	3/4"	3/8"	5 5/8"	-	125	75	60
405TS*	20	17 3/4"	10	8	6 7/8"	13/16"	6 5/8"	4 1/4"	2 1/8"	1/2"	1/4"	2 3/4"	150	-	-	-
444T	22	18 1/2"	11	9	7 1/4"	13/16"	7 1/2"	8 1/2"	3 3/8"	7/8"	7/16"	6 7/8"	-	-	100	75
444TS*	22	18 1/2"	11	9	7 1/4"	13/16"	7 1/2"	4 3/4"	2 3/8"	5/8"	5/16"	3	200	150	-	-
445T	22	20 1/2"	11	9	8 1/4"	13/16"	7 1/2"	8 1/2"	3 3/8"	7/8"	7/16"	6 7/8"	-	-	125	100
445TS*	22	20 1/2"	11	9	8 1/4"	13/16"	7 1/2"	4 3/4"	2 3/8"	5/8"	5/16"	3	250	200	-	-

* These motors are for direct coupled service only.
▲ Slots.



Decimal - Millimeter Equivalents

Fractional	Decimal	M.M.	Fractional	Decimal	M. M.
1/64	.015625	.397	33/64	.515625	13.097
1/32	.03125	.794	17/32	.53125	13.494
	.046875	1.191	35/64	.546875	13.891
1/16	.0625	1.588	9/16	.5625	14.288
	.078125	1.985	37/64	.578125	14.684
3/32	.09375	2.381	19/32	.59375	15.081
	.109375	2.778	39/64	.609375	15.478
1/8	.125	3.175	5/8	.625	15.875
	.140625	3.572	41/64	.640625	16.272
5/32	.15625	3.969	21/32	.65625	16.669
	.171875	4.366	43/64	.671875	17.066
3/16	.1875	4.763	11/16	.6875	17.463
	.203125	5.159	45/64	.703125	17.859
7/32	.21875	5.556	23/32	.71875	18.256
	.234375	5.953	47/64	.734375	18.653
1/4	.250	6.350	3/4	.750	19.050
	.265625	6.747	49/64	.765625	19.447
9/32	.28125	7.144	25/32	.78125	19.844
	.296875	7.541	51/64	.796875	20.241
5/16	.3125	7.938	13/16	.8125	20.638
	.328125	8.334	53/64	.828125	21.034
11/32	.34375	8.731	27/32	.84375	21.431
	.359375	9.128	55/64	.859375	21.828
3/8	.375	9.525	7/8	.875	22.225
	.390625	9.922	57/64	.890625	22.622
13/32	.40625	10.319	29/32	.90625	23.019
	.421875	10.716	59/64	.921875	23.416
7/16	.4375	11.113	15/16	.9375	23.813
	.453125	11.509	61/64	.953125	24.209
15/32	.46875	11.906	31/32	.96875	24.606
	.484375	12.303	63/64	.984375	25.003
1/2	.500	12.700	1	1.000	25.400

HP and Torque

HP is the common unit of mechanical power.

$$HP = \frac{\text{Force} \times \text{Feet per Minute}}{33000}$$

$$HP = \frac{\text{Torque in In.-Lbs.} \times \text{rpm}}{63025}$$

One HP = .746 kilowatt

One kilowatt = 1.34 HP

Torque is a twisting moment or turning effort.

Torque in inch-pounds = Force x Lever Arm (Inches)

$$\text{Torque in inch-pounds} = \frac{63025 \times HP}{rpm}$$

The following table gives the torque in Inch-Pounds for one HP at various speeds.

Torque at One HP

R.P.M.	In.-Lbs.	R.P.M.	In.-Lbs.	R.P.M.	In.-Lbs.	R.P.M.	In.-Lbs.
3500	18	580	109	90	700	14	4502
3000	21	500	126	80	788	12	5252
2400	26	400	158	70	900	10	6300
2000	32	300	210	60	1050	8	7878
1750	36	200	315	50	1260	6	10504
1600	39	180	350	40	1576	5	12605
1200	53	160	394	30	2101	4	15756
1160	54	140	450	20	3151	3	21008
1000	63	120	525	18	3501	2	31513
870	72	100	630	16	3939	1	63025

Poly-V is believed to be a trademark and/or a trade name of Goodyear Tire and Rubber Co. and is not owned or controlled by Emerson Power Transmission Corporation. This trademark and/or registered trademark of others is used herein for product comparison purposes only, is the property of their respective owners and is not owned or controlled by Emerson Power Transmission Corporation. While reasonable efforts have been made to confirm ownership of the marks and names listed above, Emerson Power Transmission Corporation cannot and does not represent or warrant the accuracy of this information.

Minimum Sheave Sizes NEMA Standards

The National Electrical Manufacturers Association recommends certain limitations on sheave diameter and width for satisfactory motor operation. The selected sheave diameter should not be smaller nor the width greater than the dimensions below. These dimensions are from NEMA Standard MG1-14.42.

Frame	Horsepower at				V-Belt Sheave (Inches)			
					Conventional		358	
	Sync. Speed, RPM				A, B, C, D, and E Sections		3V, 5V and 8V Sections	
					Min. Pitch Dia.	Max. Width	Min. Outside Dia.	Max. Width
143T	1 1/2	1	3/4	1/2	2.2	4 1/4	2.2	2 1/4
145T	2-3	1 1/2-2	1	3/4	2.4	4 1/4	2.4	2 1/4
182T	3	3	1 1/2	1	2.4	5 1/4	2.4	2 3/4
182T	5	-	-	-	2.6	5 1/4	2.4	2 3/4
184T	-	-	2	1 1/2	2.4	5 1/4	2.4	2 3/4
184T	5	-	-	-	2.6	5 1/4	2.4	2 3/4
184T	7 1/2	5	-	-	3.0	5 1/4	3.0	2 3/4
213T	7 1/2-10	7 1/2	3	2	3.0	6 1/2	3.0	3 3/8
215T	10	-	5	3	3.0	6 1/2	3.0	3 3/8
215T	15	10	-	-	3.8	6 1/2	3.8	3 3/8
254T	15	-	7 1/2	5	3.8	6 1/2	3.8	4
254T	20	15	-	-	4.4	6 1/2	4.4	4
256T	20-25	-	10	7 1/2	4.4	6 1/2	4.4	4
256T	-	20	-	-	4.6	6 1/2	4.4	4
284T	-	-	15	10	4.6	9	4.4	4 5/8
284T	-	25	-	-	5.0	9	4.4	4 5/8
286T	-	30	20	15	5.4	9	5.2	4 5/8
324T	-	40	25	20	6.0	10 1/4	6.0	5 1/4
326T	-	50	30	25	6.8	10 1/4	6.8	5 1/4
364T	-	-	40	30	6.8	11 1/2	6.8	5 7/8
364T	-	60	-	-	7.4	11 1/2	7.4	5 7/8
365T	-	-	50	40	8.2	11 1/2	8.2	5 7/8
365T	-	75	-	-	9.0	11 1/2	8.6	5 7/8
404T	-	-	60	-	9.0	14 1/4	8.0	7 1/4
404T	-	-	-	50	9.0	14 1/4	8.4	7 1/4
404T	-	100	-	-	10.0	14 1/4	8.6	7 1/4
405T	-	-	75	60	10.0	14 1/4	10.0	7 1/4
405T	-	100	-	-	10.0	14 1/4	8.6	7 1/4
405T	-	125	-	-	11.5	14 1/4	10.5	7 1/4
444T	-	-	100	-	11.0	16 3/4	10.0	8 1/2
444T	-	-	-	75	10.5	16 3/4	9.5	8 1/2
444T	-	125	-	-	11.0	16 3/4	9.5	8 1/2
444T	-	150	-	-	-	-	10.5	8 1/2
445T	-	-	125	-	12.5	16 3/4	12.0	8 1/2
445T	-	-	-	100	10.5	16 3/4	12.0	8 1/2
445T	-	150	-	-	-	-	10.5	8 1/2
445T	-	200	-	-	-	-	13.2	8 1/2

To obtain the minimum pitch diameters for flat belt, gearbelt, Poly-V®, chain or gear drives, multiply the 358 sheave pitch diameters in the table above by the following factors:

Drive	Factor
Chain	0.70
Flat Belt (Single Ply)	1.33
Gearbelt	0.90
Helical Gear	0.85
Poly-V	1.00
Spur Gear	0.75

All sales are made on our STANDARD TERMS AND CONDITIONS OF SALE in effect at the time a customer's order is accepted. The current Terms and Conditions are set forth below:

STANDARD TERMS AND CONDITIONS OF SALE (August 15, 2001)

These Terms and Conditions, the attendant quotation or acknowledgment and all documents incorporated by specific reference therein, will be the complete and exclusive statement of the terms of the agreement governing the sale of goods ("Goods") by **Emerson Power Transmission Corporation** and its divisions and subsidiaries ("Seller") to Customer ("Buyer"). Buyer's acceptance of the Goods will manifest Buyer's assent to these Terms and Conditions. If these Terms and Conditions differ in any way from the terms and conditions of Buyer's order, or other documentation, this document will be construed as a counteroffer and will not be deemed an acceptance of Buyer's terms and conditions which conflict herewith.

1. **PRICES:** Unless otherwise specified in writing by Seller, Seller's price for the goods shall remain in effect for thirty (30) days after the date of Seller's quotation or acknowledgment of Buyer's order for the Goods, whichever occurs first, provided an unconditional, complete authorization for the immediate shipment of the Goods is received and accepted by Seller within such time period. If such authorization is not received by Seller within such thirty (30) day period, Seller shall have the right to change the price for the Good to Seller's price for the Goods at the time of shipment.

2. **TAXES:** Any tax or governmental charge or increase in same hereafter becoming effective increasing the cost to Seller of producing, selling or delivering the Goods or of procuring material used therein, and any tax now in effect or increase in same payable by the Seller because of the manufacture, sale or delivery of the Goods, may at Seller's option, be added to the price.

3. **TERMS OF PAYMENT:** Subject to the approval of Seller's Credit Department, terms are net thirty (30) days from date of Seller's invoice in U.S. currency. If any payment owed to Seller is not paid when due, it shall bear interest, at a rate to be determined by Seller, which shall not exceed the maximum rate permitted by law, from the date on which it is due until it is paid. Seller shall have the right, among other remedies, either to terminate the Agreement or to suspend further performance under this and/or other agreements with Buyer in the event Buyer fails to make any payment when due. Buyer shall be liable for all expenses, including attorneys' fees, relating to the collection of past due amounts.

4. **SHIPMENT AND DELIVERY:** Shipments are made F.O.B. Seller's shipping point. Any claims for shortages or damages suffered in transit shall be submitted by the Buyer directly to the carrier. While Seller will use all reasonable commercial efforts to maintain the delivery date acknowledged or quoted by Seller, all shipping dates are approximate. Seller reserves the right to make partial shipments and to segregate "specials" and made-to-order Goods from normal stock Goods. Seller shall not be bound to tender delivery of any Goods for which Buyer has not provided shipping instructions.

5. **QUANTITY:** Buyer agrees to accept overruns of up to ten percent (10%) of the order on "made-to-order" Goods, including parts. Any such additional items shall be priced at the price per item charged for the specific quantity ordered.

6. **LIMITED WARRANTY:** Subject to the limitations of Section 7, Seller warrants that the Goods will be free from defects in material and workmanship under normal use, service and maintenance for a period of one year (unless otherwise specified by Seller in writing) from the date of shipment of the Goods by Seller. **THIS IS THE SOLE AND EXCLUSIVE WARRANTY GIVEN BY SELLER WITH RESPECT TO THE GOODS AND IS IN LIEU OF AND EXCLUDES ALL OTHER WARRANTIES, EXPRESS OR IMPLIED, ARISING BY OPERATION OF LAW OR OTHERWISE, INCLUDING WITHOUT LIMITATION, MERCHANTABILITY OR FITNESS FOR A PARTICULAR PURPOSE WHETHER OR NOT THE PURPOSE OR USE HAS BEEN DISCLOSED TO SELLER IN SPECIFICATIONS, DRAWINGS OR OTHERWISE, AND WHETHER OR NOT SELLER'S PRODUCTS ARE SPECIFICALLY DESIGNED AND/OR MANUFACTURED BY SELLER FOR BUYER'S USE OR PURPOSE.**

This warranty does not extend to any losses or damages due to misuse, accident, abuse, neglect, normal wear and tear, unauthorized modification or alteration, use beyond rated capacity, or improper installation, maintenance or application. To the extent that Buyer or its agents has supplied specifications, information, representation of operating conditions or other data to Seller in the selection or design of the Goods and the preparation of Seller's quotation, and in the event that actual operating conditions or other conditions differ from those represented by Buyer, any warranties or other provisions contained herein which are affected by such conditions shall be null and void. If within thirty (30) days after Buyer's discovery of any warranty defects within the warranty period, Buyer notifies Seller thereof in writing, Seller shall, at its option, repair or replace F.O.B. point of manufacture, or refund the purchase price for, that portion of the goods found by Seller to be defective. Failure by Buyer to give such written notice within the applicable time period shall be deemed an absolute and unconditional waiver of Buyer's claim for such defects. Goods repaired or replaced during the warranty period shall be covered by the foregoing warranty for the remainder of the original warranty period or ninety (90) days, whichever is longer. Buyer assumes all other responsibility for any loss, damage, or injury to persons or property arising out of, connected with, or resulting from the use of Goods, either alone or in combination with other products/components.

SECTIONS 6 AND 7 APPLY TO ANY ENTITY OR PERSON WHO MAY BUY, ACQUIRE OR USE SELLER'S GOODS, INCLUDING ANY ENTITY OR PERSON WHO BUYS THE GOODS FROM SELLER'S DISTRIBUTOR AND SUCH ENTITY OR PERSON SHALL BE BOUND BY THE LIMITATIONS THEREIN.

7. **LIMITATION OF REMEDY AND LIABILITY: THE SOLE AND EXCLUSIVE REMEDY FOR BREACH OF ANY WARRANTY HEREUNDER (OTHER THAN THE WARRANTY PROVIDED UNDER SECTION 13) SHALL BE LIMITED TO REPAIR, REPLACEMENT OR REFUND OF THE PURCHASE PRICE UNDER SECTION 6. SELLER SHALL NOT BE LIABLE FOR DAMAGES CAUSED BY DELAY IN PERFORMANCE AND IN NO EVENT, REGARDLESS OF THE FORM OF THE CLAIM OR CAUSE OF ACTION (WHETHER BASED IN CONTRACT, INFRINGEMENT, NEGLIGENCE, STRICT LIABILITY, OTHER TORT OR OTHERWISE), SHALL SELLER'S LIABILITY TO BUYER AND/OR ITS CUSTOMERS EXCEED THE PRICE TO BUYER OF THE SPECIFIC GOODS PROVIDED BY SELLER GIVING RISE TO THE CLAIM OR CAUSE OF ACTION. BUYER AGREES THAT IN NO EVENT SHALL SELLER'S LIABILITY TO BUYER AND/OR ITS CUSTOMERS EXTEND TO INCLUDE INCIDENTAL, CONSEQUENTIAL OR PUNITIVE DAMAGES. THE TERM "CONSEQUENTIAL DAMAGES" SHALL INCLUDE, BUT NOT BE LIMITED TO, LOSS OF ANTICIPATED PROFITS, LOSS OF USE, LOSS OF REVENUE, COST OF CAPITAL AND DAMAGE OR LOSS OF OTHER PROPERTY OR EQUIPMENT.**

It is expressly understood that any technical advice furnished by Seller with respect to the use of the Goods is given without charge, and Seller assumes no obligation or liability for the advice given, or results obtained, all such advice being given and accepted at Buyer's risk.

GOODS AND/OR SERVICES SOLD HEREUNDER ARE NOT FOR USE IN ANY NUCLEAR AND RELATED APPLICATIONS. Buyer accepts goods and/or services with the foregoing understanding, agrees to communicate the same in writing to any subsequent purchaser or users and to defend, indemnify and hold harmless Seller from any claims, losses, suits, judgments and damages, including incidental and consequential damages, arising from such use, whether the cause of action be based in tort, contract or otherwise, including allegations that the Seller's liability is based on negligence or strict liability.

8. **EXCUSE OF PERFORMANCE:** Seller shall not be liable for delays in performance or for non-performance due to acts of God, acts of Buyer, war, riot, fire, flood, other severe weather, sabotage, or epidemics; strikes or labor disturbances; governmental requests, restrictions, laws, regulations, orders or actions; unavailability of or delays in transportation; default of suppliers; or unforeseen circumstances or any events or causes beyond Seller's reasonable control. Deliveries may be suspended for an appropriate period of time as a result of the foregoing. If Seller determines that its ability to supply the total demand for the Goods, or to obtain material used directly or indirectly in the manufacture of the Goods, is hindered, limited or made impracticable due to causes addressed in this Section 8, Seller may allocate its available supply of the Goods or such material (without obligation to acquire other supplies of any such Goods or material) among itself and its purchasers on such basis as Seller determines to be equitable without liability for any failure of performance which may result therefrom. Deliveries suspended or not made by reason of this section may be canceled by Seller upon notice to Buyer without liability, but the balance of the agreement shall otherwise remain unaffected.

9. **CANCELLATION:** The Buyer may cancel orders only upon written notice and upon payment to Seller of cancellation charges which include, among other things, all costs and expenses incurred and commitments made by the Seller and a reasonable profit thereon.

10. **CHANGES:** Buyer may request changes or additions to the Goods consistent with Seller's specifications and criteria. In the event such changes or additions are accepted by Seller, Seller may revise the price and delivery schedule. Seller reserves the right to change designs and specifications for the Goods without prior notice to Buyer, except with respect to Goods being made-to-order for Buyer.

11. **TOOLING:** Tool, die, and pattern charges, if any, are in addition to the price of the Goods and are due and payable upon completion of the tooling. All such tools, dies and patterns shall be and remain the property of Seller. Charges for tools, dies, and patterns do not convey to Buyer, title, ownership interests in, or rights to possession or removal, nor prevent their use by Seller for other purchasers, except as otherwise expressly provided by Seller and Buyer in writing with reference to this provision.

12. **ASSIGNMENT:** Buyer shall not assign its rights or delegate its duties hereunder or any interest therein or any rights hereunder without the prior written consent of the Seller, and any such assignment, without such consent, shall be void.

13. **PATENTS AND COPYRIGHTS:** Subject to Section 7, Seller warrants that the Goods sold, except as are made specifically for Buyer according to Buyer's specifications, do not infringe any valid U.S. patent or copyright in existence as of the date of delivery. This warranty is given upon the condition that Buyer promptly notify Seller of any claim or suit involving Buyer in which such infringement is alleged, and that Buyer cooperate fully with Seller and permit Seller to control completely the defense or compromise of any such allegation of infringement. Seller's warranty as to use only applies to infringements arising solely out of the inherent operation (i) of such Goods, or (ii) of any combination of Goods in a system designed by Seller. In the event such Goods, singularly or in combination, are held to infringe a U.S. patent or copyright in such suit, and the use of such Goods is enjoined, or in the case of a compromise by Seller, Seller shall have the right, at its option and expense, to procure for Buyer the right to continue using such Goods, or replace them with non-infringing Goods; or modify same to become non-infringing; or grant Buyer a credit for the depreciated value of such Goods and accept return of them.

14. **MISCELLANEOUS:** These terms and conditions set forth the entire understanding and agreement between Seller and Buyer, and supersede all other communications, negotiations and prior oral or written statements regarding the subject matter of these terms and conditions. No change, modification, rescission, discharge, abandonment, or waiver of these terms and conditions of Sale shall be binding upon the Seller unless made in writing and signed on its behalf by an officer of the Seller. No conditions, usage or trade, course of dealing or performance, understanding or agreement purporting to modify, vary, explain, or supplement these Terms and Conditions shall be binding unless hereafter made in writing and signed by the party to be bound, and no modification shall be affected by the acceptance of purchase orders or shipping instruction forms containing terms at variance with or in addition to those set forth herein. Any such modifications or additional terms are specifically rejected by Seller. No waiver by Seller with respect to any breach or default or any right or remedy and no course of dealing, shall be deemed to constitute a continuing waiver of any other breach or default or of any other right or remedy, unless such waiver be expressed in writing and signed by the party to be bound. Seller is not responsible for typographical or clerical errors made in any quotation, orders or publications. All such errors are subject to correction. The validity, performance, and all other matters relating to the interpretation and effect of this contract shall be governed by the law of the state of New York. The United Nations Convention on the International Sale of Goods shall not apply to any transaction hereunder.

Experience the Power of EPT Edge Online

EPT Edge Online is our online technical support center.

Also available "24-7-365," these electronic tools provide for efficient drive design and product selection:

- **eCatalog (an industry first)** - an interactive, robust electronic "database" with over 100,000 part numbers searchable by part number or general description providing features and benefits of each product line
- **Product Selection (an industry first)** - selection tools with extensive engineering efficiency benefits
- **Smart Interchange** - a dynamic tool that provides the user an intelligent interchange for competitive parts
- **Media Library** - digital (PDF) version of paper catalogs, documents, and downloadable installation and maintenance instructions
- **CAD** - an online service that allows users to view and upload a 2D or 3D CAD template drawing in a number of customer-compatible formats to be integrated into your drawings

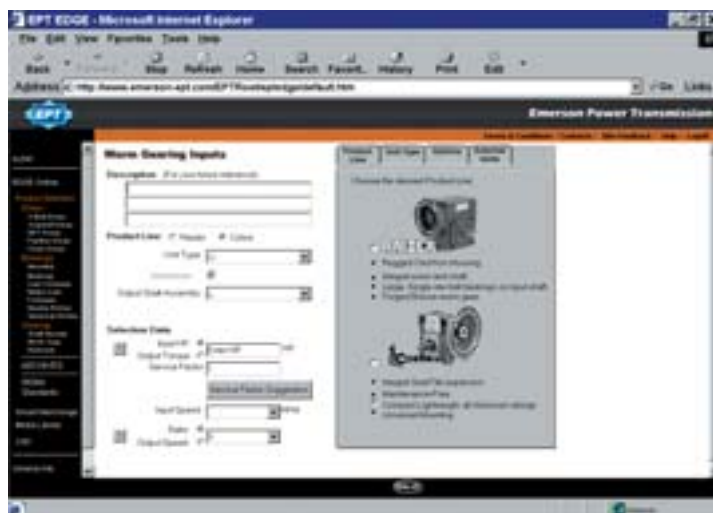

www.emerson-ept.com

Connect Here To Be Part of Something Bigger





Browning

Helical Speed
Reducers & Gearmotors



SEALMASTER

Mounted Ball Bearings



Morse

Clutches



Browning

Shaft Mount Reducers



SEALMASTER

Mounted Roller Bearings



ROLLWAY

Roller Bearings



Browning

V-Belt Drives



Morse

Chain



KOP-FLEX

Couplings



Browning

MXP Motorized Pulleys



Morse

Worm Gearing



McGILL

Precision Bearings

Emerson Power Transmission Customer Service

Telephone 1-800-626-2120
Fax 1-800-262-3292

Emerson Power Transmission
Maysville, KY 41056
Telephone 606-564-2011
Fax 606-564-2052

Emerson Power Transmission
7120 New Buffington Rd.
P.O. Box 728
Florence, KY 41022
Telephone 859-342-7900
Fax 859-342-5652

Emerson Power Transmission - West
3553 Placentia Ct.
Chino, CA 91710
Telephone 909-591-9561
Fax 909-628-1983

Emerson Power Transmission - Export
7120 New Buffington Rd.
Florence, KY 41042
Telephone 859-727-5273
Fax 859-727-0721

Emerson Power Transmission - Canada
16 Main Street
Unionville, ONT L3R 2E4
Telephone 905-294-9330
1-800-268-4149
Fax 1-800-668-9005

Kop-Flex, Inc.
P. O. Box 1696
Baltimore, MD 21203
Telephone Plant 410-768-2000
Fax 410-787-8424

Kop-Flex Canada, Ltd.
19 Meteor Drive
Rexdale, ONT M9W 1A3
Telephone 416-675-7144
Fax 416-675-6764

McGill Manufacturing Co., Inc.
909 North Lafayette St.
Valparaiso, IN 46383
Aerospace Bearings Telephone 219-465-2200
Aerospace Bearings Fax 219-465-2290

Catalog O1N-07
Form #9029 • 2/07 • 7M • Printed in U.S.

Application Considerations

The proper selection and application of power transmission products and components, including the related area of product safety is the responsibility of the customer. Operating and performance requirements and potential associated issues will vary appreciably depending upon the use and application of such products and components. The scope of the technical and application information included in this publication is necessarily limited. Unusual operating environments and conditions, lubrication requirements, loading supports, and other factors can materially affect the application and operating results of the products and components and the customer should carefully review its requirements. Any technical advice or review furnished by Emerson Power Transmission Corporation and its divisions with respect to the use of products and components is given in good faith and without charge, and Emerson assumes no obligation or liability for the advice given, or results obtained, all such advice and review being given and accepted at customer's risk.

For a copy of our Standard Terms and Conditions of Sale, Disclaimers of Warranty, Limitation of Liability and Remedy, please contact Emerson Power Transmission Customer Service at 1-800-626-2120. These terms and conditions of sale, disclaimers and limitations of liability apply to any person who may buy, acquire or use an Emerson Power Transmission Corporation product referred to herein, including any person who buys from a licensed distributor of these branded products.

www.emerson-ept.com